



X46x Series

User's Guide

August 2011

www.lexmark.com

Machine type(s):

7014, 4569, 4570

Model(s):

431, 636, 63W, n01, n02, g01, g02, n11, n12, g11, g12, hn1, hn2, wh1, wh2

Contents

- Safety information.....14**

- Learning about the printer.....16**
 - Thank you for choosing this printer!.....16
 - Finding information about the printer.....16
 - Printer configurations.....17
 - Selecting a location for the printer.....19
 - Basic functions of the scanner.....20
 - Understanding the ADF and scanner glass.....21
 - Understanding the printer control panel.....22
 - Understanding the home screen.....23
 - Using the touch-screen buttons.....24

- Additional printer setup.....28**
 - Installing internal options.....28
 - Available internal options 28
 - Accessing the system board to install internal options 29
 - Installing a memory card 31
 - Installing a flash memory or firmware card.....33
 - Installing an Internal Solutions Port.....35
 - Installing a printer hard disk 42
 - Installing a fax card 46
 - Installing hardware options.....49
 - Installing a 250- or 550-sheet drawer 49
 - Attaching cables.....50
 - Verifying printer setup.....51
 - Printing a menu settings page 51
 - Printing a network setup page..... 52
 - Setting up the printer software.....52
 - Installing printer software 52
 - Updating available options in the printer driver 53
 - Setting up wireless printing.....54
 - Follow these steps to set up your printer 54
 - Information you will need to set up the printer on a wireless network..... 54
 - Installing the printer on a wireless network (Windows)..... 55
 - Installing the printer on a wireless network (Macintosh)..... 58
 - Installing the printer on a wired network.....61

Changing port settings after installing a new network Internal Solutions Port.....64
 Setting up serial printing.....66

Minimizing your printer's environmental impact.....68

Saving paper and toner.....68
 Using recycled paper 68
 Conserving supplies 68
 Saving energy.....69
 Using Eco-Mode..... 69
 Adjusting Power Saver 70
 Adjusting the brightness of the display 70
 Setting the standard exit bin light..... 71
 Recycling.....72
 Recycling Lexmark products 72
 Recycling Lexmark packaging..... 72
 Returning Lexmark cartridges for reuse or recycling..... 72
 Reducing printer noise.....73

Loading paper and specialty media.....74

Setting the Paper Size and Paper Type.....74
 Configuring Universal paper settings.....74
 Avoiding jams.....75
 Loading trays.....75
 Using the multipurpose feeder.....79
 Linking and unlinking trays.....84
 Linking trays.....84
 Unlinking trays84
 Assigning a custom paper type name85
 Changing a Custom Type <x> name85

Paper and specialty media guidelines.....87

Paper guidelines.....87
 Paper characteristics.....87
 Unacceptable paper.....88
 Selecting paper88
 Using recycled paper and other office papers88
 Selecting preprinted forms and letterhead89
 Storing paper89
 Supported paper sizes, types, and weights.....90
 Paper sizes supported by the printer.....90
 Paper types and weights supported by the printer91

Paper capacities 92

Printing.....93

Printing a document..... 93

Printing on both sides of the paper (duplexing)..... 93

Printing on specialty media..... 94

 Tips on using letterhead 94

 Tips on using transparencies 94

 Tips on using envelopes..... 94

 Tips on using labels 95

 Tips on using card stock..... 96

Printing confidential and other held jobs..... 96

 Holding jobs in the printer 96

 Printing confidential and other held jobs from Windows..... 97

 Printing confidential and other held jobs from a Macintosh computer 97

Printing from a flash drive..... 98

Printing information pages..... 99

 Printing a font sample list 99

 Printing a directory list..... 99

 Printing the print quality test pages 100

Canceling a print job..... 100

 Canceling a print job from the printer control panel..... 100

 Canceling a print job from the computer 100

Copying.....102

Making copies..... 102

 Making a quick copy 102

 Copying using the ADF 102

 Copying using the scanner glass 103

Copying photos..... 103

Copying on specialty media..... 103

 Making transparencies 103

 Copying to letterhead 104

Customizing copy settings..... 104

 Copying from one size to another 104

 Making copies using paper from a selected tray 104

 Copying on both sides of the paper (duplexing)..... 105

 Reducing or enlarging copies..... 105

 Adjusting copy quality 105

 Collating copies 106

 Placing separator sheets between copies..... 106

 Copying multiple pages onto a single sheet 107

- Creating a custom job (job build)..... 107
- Pausing the current print job to make copies..... 108
- Placing information on copies..... 109
 - Placing the date and time at the top of each page..... 109
 - Placing an overlay message on each page..... 109
- Canceling a copy job..... 109
 - Canceling a copy job while the document is in the ADF..... 109
 - Canceling a copy job while copying pages using the scanner glass 110
 - Canceling a copy job while the pages are being printed 110
- Understanding the copy screens and options..... 110
 - Copy from 110
 - Copy to..... 110
 - Scale..... 110
 - Darkness 111
 - Content 111
 - Sides (Duplex) 111
 - Collate..... 111
 - Options 111
- Improving copy quality..... 113

E-mailing.....114

- Getting ready to e-mail..... 114
 - Enabling the e-mail function..... 114
 - Setting up the e-mail function 115
 - Configuring the e-mail settings..... 115
- Creating an e-mail shortcut..... 115
 - Creating an e-mail shortcut using the Embedded Web Server..... 115
 - Creating an e-mail shortcut using the touch screen 116
- E-mailing a document..... 116
 - Sending an e-mail using the touch screen 116
 - Sending an e-mail using a shortcut number 116
 - Sending an e-mail using the address book 117
- Customizing e-mail settings..... 117
 - Adding e-mail subject and message information 117
 - Changing the output file type 118
- Canceling an e-mail..... 118
- Understanding e-mail options..... 118
 - Original Size 118
 - Sides (Duplex) 118
 - Orientation 119
 - Binding..... 119
 - E-mail Subject 119

E-mail File Name 119
 E-mail Message 119
 Resolution 119
 Send As 119
 Content 119
 Advanced Options..... 120

Faxing.....121

Getting the printer ready to fax.....121
 Setting up the printer to fax 121
 Choosing a fax connection 121
 Connecting to an analog telephone line 122
 Connecting to a DSL service 123
 Connecting to a PBX or ISDN system 123
 Connecting to a distinctive ring service 124
 Connecting the printer and a telephone or answering machine to the same telephone line..... 124
 Connecting to an adapter for your country or region 126
 Connecting to a computer with a modem 131
 Enabling the fax function 132
 Using the Embedded Web Server for fax setup..... 133
 Setting the date and time 133
 Turning daylight saving time on or off 134
 Sending a fax.....134
 Sending a fax using the printer control panel..... 134
 Getting ready to send a fax using the computer 134
 Installing a PostScript driver 135
 Sending a fax using the computer 136
 Creating shortcuts.....137
 Creating a fax destination shortcut using the Embedded Web Server 137
 Creating a fax destination shortcut using the touch screen 137
 Using shortcuts and the address book.....138
 Using fax shortcuts 138
 Using the address book 138
 Customizing fax settings.....139
 Changing the fax resolution 139
 Making a fax lighter or darker 139
 Sending a fax at a scheduled time 139
 Printing an incoming fax on both sides of the paper (duplexing) 140
 Viewing a fax log 140
 Blocking junk faxes..... 140
 Canceling an outgoing fax.....141
 Canceling a fax while the original documents are still scanning..... 141
 Canceling a fax after the original documents have been scanned to memory..... 141

- Understanding fax options.....141
 - Original Size 141
 - Content 141
 - Sides (Duplex) 142
 - Resolution 142
 - Darkness 142
 - Advanced Options..... 142
- Improving fax quality.....143
- Holding and forwarding faxes.....143
 - Holding faxes 143
 - Forwarding a fax 144

Scanning to an FTP address.....145

- Scanning to an FTP address.....145
 - Scanning to an FTP address using the keypad 145
 - Scanning to an FTP address using a shortcut number 145
 - Scanning to an FTP address using the address book 146
- Creating shortcuts.....146
 - Creating an FTP shortcut using the Embedded Web Server 146
 - Creating an FTP shortcut using the touch screen 147
- Understanding FTP options.....147
 - Original Size 147
 - Sides (Duplex) 147
 - Orientation 147
 - Binding 147
 - Resolution 147
 - Send As 148
 - Content 148
 - Advanced Options..... 148
- Improving FTP quality.....149

Scanning to a computer or flash drive.....150

- Scanning to a computer.....150
- Understanding scan profile options.....151
 - Quick Setup..... 151
 - Format Type..... 151
 - Compression 151
 - Default Content 151
 - Color 152
 - Original Size 152
 - Orientation 152
 - Duplex..... 152

JPEG Quality.....	152
Darkness	152
Resolution	152
Advanced Imaging.....	152
Scanning to a flash drive.....	153
Improving scan quality.....	153

Understanding printer menus.....154

Menu list.....	154
Paper menu.....	155
Default Source menu	155
Paper Size/Type menu	155
Configure MP menu	158
Substitute Size menu	158
Paper Texture menu	159
Paper Weight menu	160
Paper Loading menu	160
Custom Types menu	162
Custom Names menu	162
Custom Scan Sizes menu	162
Universal Setup menu.....	163
Reports menu.....	164
Network/Ports menu.....	165
Active NIC menu	165
Standard Network or Network <x> menus	165
SMTP Setup menu	167
Network Reports menu	168
Network Card menu.....	168
TCP/IP menu	169
IPv6 menu	170
Wireless menu	171
AppleTalk menu	171
NetWare menu	171
LexLink menu	172
Standard USB menu	173
Parallel <x> menu	174
Serial <x> menu	176
Security menu.....	179
Miscellaneous menu	179
Confidential Print menu.....	179
Disk Wiping menu.....	180
Security Audit Log menu	181
Set Date/Time menu.....	182

Settings menu.....	183
General Settings menu	183
Copy Settings menu	189
Fax Settings menu.....	195
E-mail Settings menu	204
FTP Settings menu	209
Flash Drive menu	212
Print Settings.....	217
Help menu.....	228
Maintaining the printer.....	229
Cleaning the exterior of the printer.....	229
Cleaning the scanner glass.....	229
Cleaning the ADF separator rollers.....	230
Adjusting scanner registration.....	231
Storing supplies.....	232
Checking the status of supplies.....	233
Checking the status of supplies from the printer control panel	233
Checking the status of supplies from a network computer	233
Ordering supplies.....	234
Ordering toner cartridges	234
Ordering a photoconductor kit	234
Ordering ADF replacement parts.....	235
Moving the printer to another location.....	235
Shipping the printer.....	236
Administrative support.....	237
Finding advanced networking and administrator information.....	237
Using the Embedded Web Server.....	237
Checking the device status.....	237
Setting up e-mail alerts.....	237
Viewing reports.....	238
Restoring the factory default settings.....	238
Clearing jams.....	239
Clearing jams.....	239
Understanding jam messages and locations.....	239
200 and 201 paper jams	241
202 paper jam.....	243
231 paper jam.....	244

233 paper jam 245
 234 paper jam 246
 235 paper jam 246
 240–249 paper jams 246
 250 paper jam 247
 251 paper jam 248
 290–294 paper jams 250

Troubleshooting.....254

Solving basic printer problems..... 254
 Printer control panel display is blank or displays only diamonds..... 254
 Indicator light blinks red..... 254
 Check the display for error messages 254
 Make sure the fax function is set up properly 254
 Understanding printer messages..... 254
 Answering 254
 Change <src> to <x>..... 255
 Check tray <x> connection..... 255
 Close front door 255
 Close door or insert cartridge 255
 Connect <x>bps 255
 Disk corrupted 256
 Disk Full - Scan Job Canceled 256
 Fax failed..... 256
 Fax memory full 256
 Fax partition inoperative. Contact system administrator. 256
 Fax server 'To Format' not set up. Contact system administrator..... 256
 Fax Station Name not set up..... 256
 Fax Station Number not set up..... 257
 Insert Tray <x> 257
 Install Tray <x> 257
 Invalid PIN..... 257
 Load <src> with <x> 257
 Load manual feeder with <x> 258
 Memory full, cannot print faxes 258
 Network/Network <x> 258
 No analog phone line connected to modem, fax is disabled..... 258
 No answer..... 258
 No dial tone 258
 Paper Change: Load Tray<x> <paper type> 258
 Queued for sending 258
 Remove originals from the scanner ADF 259
 Remove packaging material, check <x>..... 259
 Remove paper from standard output bin..... 259

Replace <x> if restarting job	259
Restore Held Jobs?.....	259
Scan Document Too Long	259
Scanner ADF Cover Open.....	259
Securely clearing disk space.....	259
Serial <x>.....	260
Set clock.....	260
SMTP server not set up. Contact system administrator.	260
Some held jobs were not restored	260
System busy, preparing resources for job.	260
System busy, preparing resources for job. Deleting held job(s).	260
Unsupported disk.....	260
Unsupported USB device, please remove.....	260
Unsupported USB hub, please remove.....	260
USB/USB <x>	260
30 Invalid refill, change toner cartridge.....	261
31 Replace defective cartridge	261
32 Cartridge part number unsupported by device	261
34 Short paper	261
35 Insufficient memory to support Resource Save feature	261
37 Insufficient memory to collate job.....	261
37 Insufficient memory, some Held Jobs were deleted.....	261
37 Insufficient memory, some held jobs will not be restored	262
38 Memory full	262
39 Complex page, some data may not have printed	262
50 PPDS font error	262
51 Defective flash detected	262
52 Not enough free space in flash memory for resources.....	262
53 Unformatted flash detected	263
54 Network <x> software error	263
54 Serial option <x> error	263
54 Standard network software error	263
55 Unsupported option in slot <x>	263
56 Parallel port <x> disabled.....	264
56 Serial port <x> disabled.....	264
56 Standard parallel port disabled.....	264
56 Standard USB port disabled	264
56 USB port <x> disabled	264
57 Configuration change, held jobs were not restored	265
58 Too many trays attached	265
58 Too many flash options installed	265
59 Incompatible tray <x>	265
61 Remove defective disk	265
62 Disk full	266
63 Unformatted disk.....	266

80 Routine maintenance needed.....	266
84 Replace PC Kit	266
84 PC Kit life warning	266
88 Cartridge low	266
88.yy Cartridge nearly low	266
88.yy Replace cartridge.....	266
200–282.yy paper jam	267
290-295.yy scanner jam.....	267
293 Replace all originals if restarting job.....	267
293.02 Flatbed Cover Open	267
294 ADF Jam	267
840.01 Scanner Disabled	268
841-846 Scanner Service Error	268
900–999 Service <message>	268
1565 Emulation error, load emulation option	268
Solving printing problems.....	268
Multiple-language PDFs do not print.....	268
Error message about reading USB drive appears	269
Jobs do not print	269
Confidential and other held jobs do not print	270
Job takes longer than expected to print.....	270
Job prints from the wrong tray or on the wrong paper.....	271
Incorrect characters print	271
Tray linking does not work.....	271
Large jobs do not collate.....	271
Unexpected page breaks occur.....	272
Solving copy problems.....	272
Copier does not respond	272
Scanner unit does not close.....	272
Poor copy quality	273
Partial document or photo copies	274
Solving scanner problems.....	275
Checking an unresponsive scanner.....	275
Scan was not successful.....	275
Scanning takes too long or freezes the computer	275
Poor scanned image quality.....	275
Partial document or photo scans.....	276
Cannot scan from a computer	276
Solving fax problems.....	277
Caller ID is not shown	277
Cannot send or receive a fax	277
Can send but not receive faxes.....	279
Can receive but not send faxes.....	279
Received fax has poor print quality	280

Solving option problems.....	280
Option does not operate correctly or quits after it is installed	280
Drawers.....	281
Flash memory card	281
Hard disk with adapter	281
Internal Solutions Port.....	282
Memory card	282
Solving paper feed problems.....	282
Paper frequently jams.....	282
Paper trays.....	283
Paper jam message remains after jam is cleared	283
Page that jammed does not reprint after you clear the jam	283
Solving print quality problems.....	284
Isolating print quality problems.....	284
Blank pages.....	284
Characters have jagged or uneven edges	285
Clipped images.....	285
Ghost images.....	285
Gray background.....	286
Incorrect margins.....	286
Paper curl.....	287
Print irregularities.....	287
Skewed print.....	288
Solid black or white streaks	288
Print is too light.....	289
Print is too dark	290
Streaked vertical lines.....	291
Toner fog or background shading appears on the page	292
Toner rubs off	292
Toner specks	293
Transparency print quality is poor	293
Embedded Web Server does not open.....	293
Check the network connections	293
Check the network settings	294
Contacting Customer Support.....	294
Notices.....	295
Product information.....	295
Edition notice.....	295
Power consumption.....	299
Index.....	314

Safety information

 **CAUTION—POTENTIAL INJURY:** See the enclosed *Safety Sheet* before making any cable or electrical connection.

Connect the power cord to a properly grounded electrical outlet that is near the product and easily accessible.

Do not place or use this product near water or wet locations.

 **CAUTION—SHOCK HAZARD:** Do not use the fax feature during a lightning storm. Do not set up this product or make any electrical or cabling connections, such as the fax feature, power cord, or telephone, during a lightning storm.

Refer service or repairs, other than those described in the user documentation, to a professional service person.

 **CAUTION—POTENTIAL INJURY:** This product uses a laser. Use of controls or adjustments or performance of procedures other than those specified herein may result in hazardous radiation exposure.

This product uses a printing process that heats the print media, and the heat may cause the media to release emissions. You must understand the section in your operating instructions that discusses the guidelines for selecting print media to avoid the possibility of harmful emissions.

Use care when you replace a lithium battery.

 **CAUTION—POTENTIAL INJURY:** There is a danger of explosion if a lithium battery is incorrectly replaced. Replace it only with the same or an equivalent type of lithium battery. Do not recharge, disassemble, or incinerate a lithium battery. Discard used batteries according to the manufacturer's instructions and local regulations.

 **CAUTION—HOT SURFACE:** The inside of the printer might be hot. To reduce the risk of injury from a hot component, allow the surface to cool before touching.

 **CAUTION—POTENTIAL INJURY:** The printer weight is greater than 18 kg (40 lb) and requires two or more trained personnel to move it safely.

 **CAUTION—POTENTIAL INJURY:** Before moving the printer, follow these guidelines to avoid personal injury or printer damage:

- Turn the printer off using the power switch, and then unplug the power cord from the wall outlet.
- Disconnect all cords and cables from the printer before moving it.
- Lift the printer off the optional drawer, and set it aside instead of trying to lift the drawer and printer at the same time.

Note: Use the handholds located on both sides of the printer to lift it off the optional drawer.

Use only the power cord provided with this product or the manufacturer's authorized replacement.

Use only the telecommunications (RJ-11) cord provided with this product or a 26 AWG or larger replacement when connecting this product to the public switched telephone network.

 **CAUTION—SHOCK HAZARD:** If you are accessing the system board or installing optional hardware or memory devices sometime after setting up the printer, then turn the printer off, and unplug the power cord from the wall outlet before continuing. If you have any other devices attached to the printer, then turn them off as well, and unplug any cables going into the printer.

 **CAUTION—SHOCK HAZARD:** Make sure that all external connections (such as Ethernet and telephone system connections) are properly installed in their marked plug-in ports.

This product is designed, tested, and approved to meet strict global safety standards with the use of specific manufacturer's components. The safety features of some parts may not always be obvious. The manufacturer is not responsible for the use of other replacement parts.

 **CAUTION—POTENTIAL INJURY:** Do not cut, twist, bind, crush, or place heavy objects on the power cord. Do not subject the power cord to abrasion or stress. Do not pinch the power cord between objects such as furniture and walls. If any of these things happen, a risk of fire or electrical shock results. Inspect the power cord regularly for signs of such problems. Remove the power cord from the electrical outlet before inspecting it.

 **CAUTION—SHOCK HAZARD:** To avoid the risk of electric shock when cleaning the exterior of the printer, unplug the power cord from the wall outlet and disconnect all cables from the printer before proceeding.

 **CAUTION—TIPPING HAZARD:** Floor-mounted configurations require additional furniture for stability. You must use either a printer stand or printer base if you are using a high-capacity input tray, a duplex unit and an input option, or more than one input option. If you purchased a multifunction printer (MFP) that scans, copies, and faxes, you may need additional furniture. For more information, see www.lexmark.com/multifunctionprinters.

SAVE THESE INSTRUCTIONS.

Learning about the printer

Thank you for choosing this printer!

We've worked hard to make sure it will meet your needs.

To start using your new printer right away, use the setup materials that came with the printer, and then skim the *User's Guide* to learn how to perform basic tasks. To get the most out of your printer, read the *User's Guide* carefully, and make sure you check the latest updates on our Web site.

We're committed to delivering performance and value with our printers, and we want to make sure you're satisfied. If you do encounter any problems along the way, one of our knowledgeable support representatives will be delighted to help you get back on track fast. And if you find something we could do better, please let us know. After all, you are the reason we do what we do, and your suggestions help us do it better.

Finding information about the printer

What are you looking for?	Find it here
Initial setup instructions: <ul style="list-style-type: none"> • Connecting the printer • Installing the printer software 	Setup documentation—The setup documentation came with the printer and is also available on the Lexmark Web site at www.lexmark.com/publications/ .
Additional setup and instructions for using the printer: <ul style="list-style-type: none"> • Selecting and storing paper and specialty media • Loading paper • Performing printing, copying, scanning, and faxing tasks, depending on your printer model • Configuring printer settings • Viewing and printing documents and photos • Setting up and using printer software • Setting up and configuring the printer on a network, depending on your printer model • Caring for and maintaining the printer • Troubleshooting and solving problems 	<i>User's Guide</i> —The <i>User's Guide</i> is available on the <i>Software and Documentation CD</i> . For updates, check our Web site at www.lexmark.com/publications/ .
Help using the printer software	Windows or Mac Help—Open a printer software program or application, and then click Help . Click  to view context-sensitive information. Notes: <ul style="list-style-type: none"> • The Help installs automatically with the printer software. • The printer software is located in the printer Program folder or on the desktop, depending on your operating system.

What are you looking for?	Find it here
<p>The latest supplemental information, updates, and technical support:</p> <ul style="list-style-type: none"> • Documentation • Driver downloads • Live chat support • E-mail support • Telephone support 	<p>Lexmark Support Web site—support.lexmark.com</p> <p>Note: Select your region, and then select your product to view the appropriate support site.</p> <p>Support telephone numbers and hours of operation for your region or country can be found on the Support Web site or on the printed warranty that came with your printer.</p> <p>Record the following information (located on the store receipt and the back of the printer), and have it ready when you contact support so that they may serve you faster:</p> <ul style="list-style-type: none"> • Machine Type number • Serial number • Date purchased • Store where purchased
<p>Warranty information</p>	<p>Warranty information varies by country or region:</p> <ul style="list-style-type: none"> • In the US—See the Statement of Limited Warranty included with this printer, or at support.lexmark.com. • Rest of the world—See the printed warranty that came with your printer.

Printer configurations

Note: Printer configuration may vary depending on your printer model.

Basic model

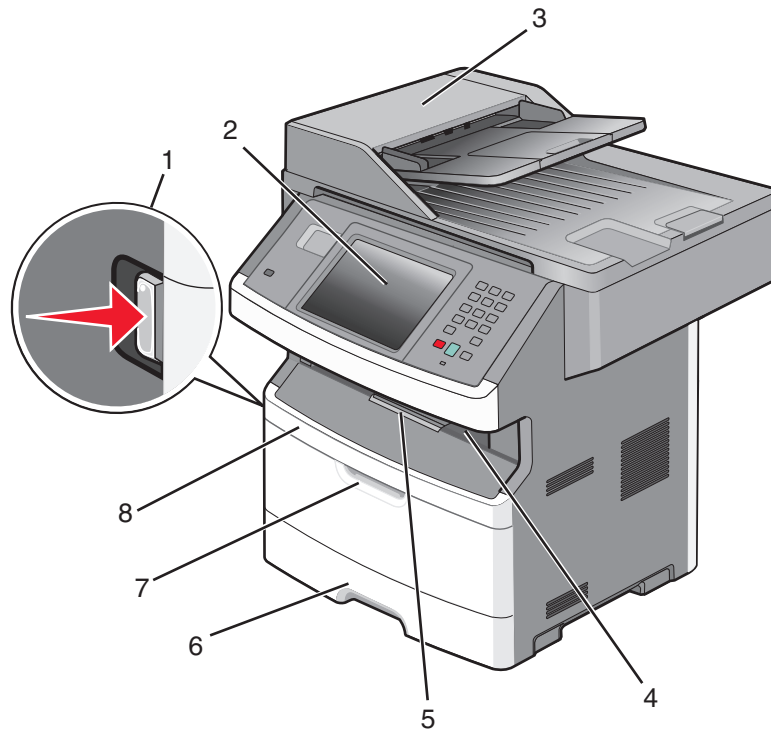

1	Front door release button
2	Printer control panel
3	Automatic Document Feeder (ADF)
4	Standard exit bin with overhead light
5	Paper stop
6	Standard 250-sheet tray
7	Multipurpose feeder door
8	Front door

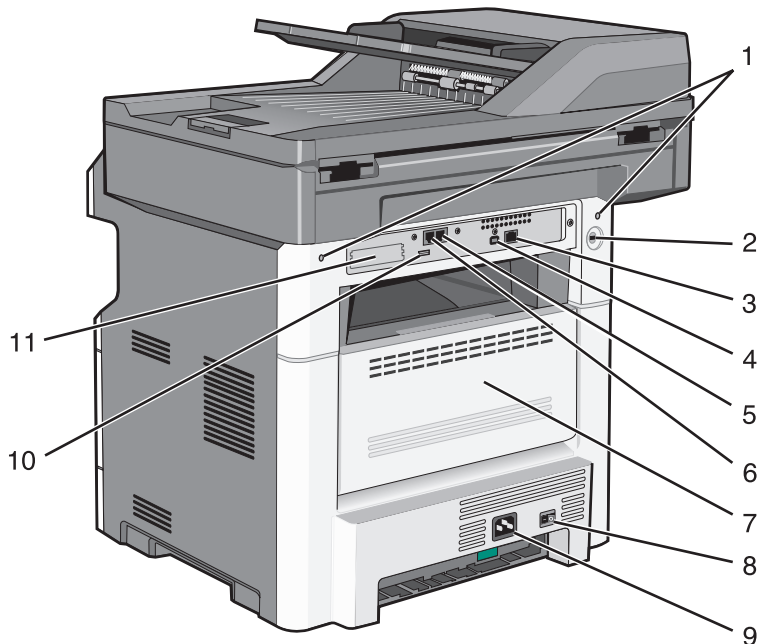

1	System board locks
2	Locking device
3	Ethernet port
4	USB port Note: Use this USB port to connect the printer to the computer.
5	Fax wall connection port Note: The Fax ports are present only when a fax card is installed.
6	Fax telephone connection port Note: The Fax ports are present only when a fax card is installed.
7	Rear door
8	Power switch
9	Printer power cord socket
10	USB peripheral port
11	Removable protective plate Note: The protective plate is removed when internal options are installed.

Selecting a location for the printer

When selecting a location for the printer, leave enough room to open trays, covers, and doors. If you plan to install any options, leave enough room for them also. It is important to:

- Make sure airflow in the room meets the latest revision of the ASHRAE 62 standard.
- Provide a flat, sturdy, and stable surface.

- Keep the printer:
 - Away from the direct airflow of air conditioners, heaters, or ventilators
 - Free from direct sunlight, humidity extremes, or temperature fluctuations
 - Clean, dry, and free of dust
- Allow the following recommended amount of space around the printer for proper ventilation:

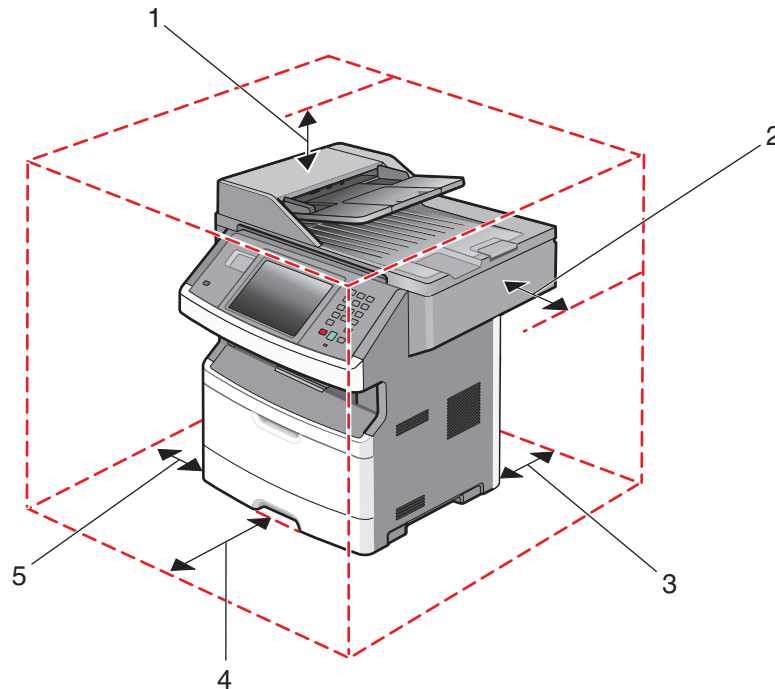

1	Top	254 mm (10 in.)
2	Right Side	203 mm (8 in.)
3	Rear	305 mm (12 in.)
4	Front	203 mm (8 in.)
5	Left Side	76 mm (3 in.)

Basic functions of the scanner

The scanner provides copy, fax, and scan-to-network capability for large workgroups. You can:

- Make quick copies, or change the settings on the printer control panel to perform specific copy jobs.
- Send a fax using the printer control panel.
- Send a fax to multiple fax destinations at the same time.
- Scan documents and send them to your computer, an e-mail address, a flash drive, or an FTP destination.
- Scan documents and send them to another printer (PDF by way of FTP).

Note: The fax function is available on selected printer models only.

Understanding the ADF and scanner glass

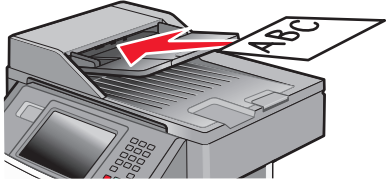
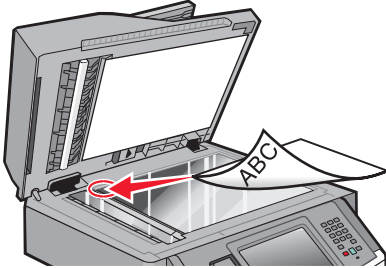
Automatic Document Feeder (ADF)	Scanner glass
 <p data-bbox="149 569 612 596">Use the ADF for multiple-page documents.</p>	 <p data-bbox="630 653 1409 741">Use the scanner glass for single pages, small items (such as postcards or photos), transparencies, photo paper, or thin media (such as magazine clippings).</p>

You can use the ADF or the scanner glass to scan documents.

Using the ADF

The ADF can scan multiple pages, including duplex pages. If duplex settings are selected, the ADF scans both sides of the page automatically. When using the ADF:

- Load the document into the ADF faceup, short edge first.
- Load up to 50 sheets of plain paper in the ADF input tray.
- Scan sizes from 125 x 127 mm (4.92 x 5.0 in.) to 215.9 x 355.6 mm (8.5 x 14 in.).
- Scan documents with mixed page sizes (letter and legal).
- Scan media weights from 52 to 120 g/m² (14 to 32 lb).
- Do not load postcards, photos, small items, transparencies, photo paper, or thin media (such as magazine clippings) into the ADF. Place these items on the scanner glass.









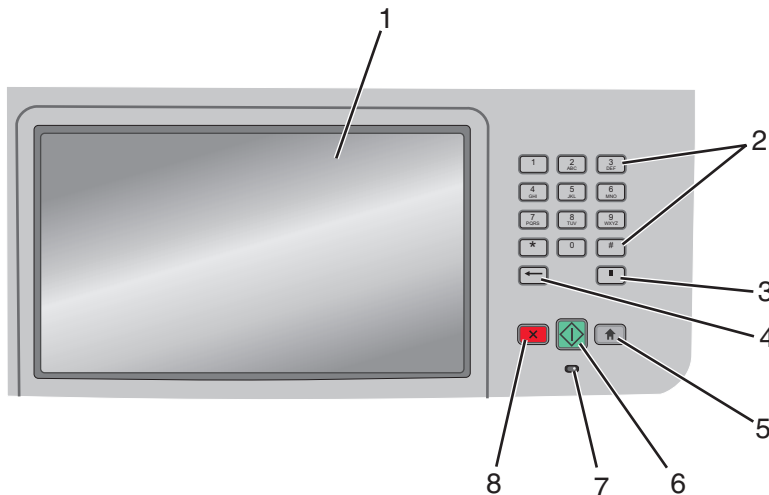





Using the scanner glass





The scanner glass can be used to scan or copy single pages or book pages. When using the scanner glass:

- Place a document facedown on the scanner glass in the upper left corner.
- Scan or copy documents up to 215.9 x 355.6 mm (8.5 x 14 in.).
- Scan documents with mixed page sizes (letter and legal).
- Copy books up to 25.3-mm (1-in.) thick.

Understanding the printer control panel



Item	Description	
1	Display	View scanning, copying, faxing, and printing options as well as status and error messages.
2	Keypad 	Enter numbers or symbols on the display.
3	Dial Pause 	<ul style="list-style-type: none"> Press  to cause a two- or three-second dial pause in a fax number. In the Fax To field, a Dial Pause is represented by a comma (,). From the home screen, press  to redial a fax number. The button functions only within the Fax menu or with fax functions. When outside of the Fax menu, fax function, or home screen, pressing  causes an error beep.
4	Back 	In the Copy menu, press  to delete the right-most digit of the value in the Copy Count. The default value of 1 appears if the entire number is deleted by pressing  numerous times. In the Fax Destination List, press  to delete the right-most digit of a number entered manually. You can also press  to delete an entire shortcut entry. Once an entire line is deleted, another press of  causes the cursor to move up one line. In the E-mail Destination List, press  to delete the character to the left of the cursor. If the character is in a shortcut, then the shortcut is deleted.
5	Home 	Press  to return to the home screen.

Item		Description
6	Start 	<ul style="list-style-type: none"> • Press  to initiate the current job indicated on the display. • From the home screen, press  to start a copy job with the default settings. • If pressed while a job is scanning, the button has no effect.
7	Indicator light	Indicates the printer status: <ul style="list-style-type: none"> • Off—The power is off. • Blinking green—The printer is warming up, processing data, or printing. • Solid green—The printer is on, but idle. • Blinking red—Operator intervention is needed.
8	Stop 	Stops all printer activity A list of options is offered once Stopped appears on the display.

Understanding the home screen

After the printer is turned on and a short warm-up period occurs, the display shows a basic screen which is referred to as the home screen. Use the home screen buttons to initiate an action such as copying, faxing, or scanning; to open the menu screen; or to respond to messages.

Note: Buttons appearing on the home screen may vary depending on home screen customization settings.

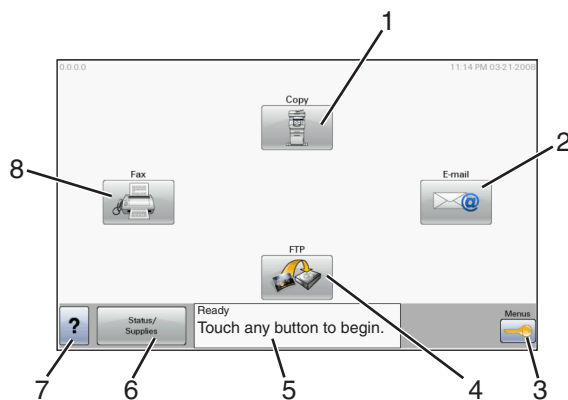

Display item		Description
1	Copy	Opens the Copy menu Note: From the home screen, you can also access the Copy menu by pressing a number on the keypad.
2	E-mail	Opens the E-mail menus
3	Menus	Opens the menus. These menus are available only when the printer is in the Ready state.
4	FTP	Opens the File Transfer Protocol (FTP) menus

Display item		Description
5	Status message bar	<ul style="list-style-type: none"> Shows the current printer status such as Ready or Busy. Shows printer conditions such as Toner Low. Shows intervention messages to give instructions on what you should do so the printer can continue processing, such as Close door.
6	Status/Supplies	Appears on the display whenever the printer status includes a message requiring intervention. Touch it to access the messages screen for more information on the message, including how to clear it.
7	Tips	All menus have a Tips button. Tips is a context-sensitive Help feature within the display touch screens.
8	Fax	Opens the Fax menus

Other buttons may appear on the home screen, such as:





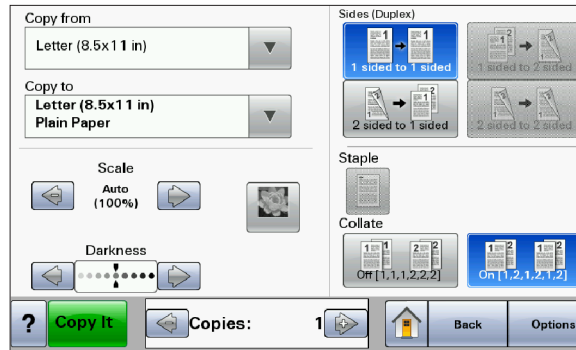

Display item	Description
Release Held Faxes	If this button is shown, then there are held faxes with a scheduled hold time previously set. To access the list of held faxes, touch this button.
Search Held Jobs	Searches on any of the following items and returns search results: <ul style="list-style-type: none"> User names for held or confidential print jobs Job names for held jobs, excluding confidential print jobs Profile names Bookmark container or job names USB container or job names for supported extensions only
Held Jobs	Opens a screen containing all the held jobs
Lock Device	This button appears on the screen when the printer is unlocked and Device Lockout Personal Identification Number (PIN) has been set. Touching this button opens a PIN entry screen. Entering the correct PIN locks the printer control panel (touch screen and hard buttons).
Unlock Device	This button appears on the screen when the printer is locked. The printer control panel buttons and shortcuts cannot be used while it appears. Touching this button opens a PIN entry screen. Entering the correct PIN unlocks the printer control panel (touch screen and hard buttons).

Using the touch-screen buttons







Note: Depending on your options and administrative setup, your screens and buttons may vary from those shown.



Sample touch screen



Button	Function
Home 	Returns to the home screen
Down arrow 	Opens an options screen
Left scroll decrease 	Scrolls to another value in decreasing order
Right scroll increase 	Scrolls to another value in increasing order
Left arrow 	Scrolls left
Right arrow 	Scrolls right
Back 	Navigates back to the previous screen

Other touch-screen buttons

Button	Function
Submit 	Saves a value as the new default setting
Down arrow 	Moves down to the next screen
Up arrow 	Moves up to the next screen
Unselected radio button 	This is an unselected radio button. The radio button is gray to show it is unselected.
Selected radio button 	This is a selected radio button. The radio button is blue to show it is selected.
Cancel Jobs 	<p>Opens the Cancel Jobs screen. The Cancel Jobs screen shows three headings: Print, Fax, and Network.</p> <p>The following items are available under the Print, Fax, and Network headings:</p> <ul style="list-style-type: none"> • Print job • Copy job • Fax • FTP • E-mail send <p>Each heading has a list of jobs shown in a column under it which can show only three jobs per screen. Each job appears as a button which you can touch to access information about the job. If more than three jobs exist in a column, then an arrow appears enabling you to scroll through the jobs.</p>
Continue 	Touch this button to accept a selection or to clear messages, and then proceed with the job.

Button	Function
Cancel 	<ul style="list-style-type: none"> • Cancels an action or a selection • Cancels out of a screen and returns to the previous screen
Select 	Opens the next related menu or menu item

Features

Feature	Description
Menu trail line: <u>Menus</u> > <u>Settings</u> > <u>Copy Settings</u> > Number of Copies	<p>A Menu trail line is located at the top of each menu screen. This feature acts as a trail, showing the path taken to arrive at the current menu. It gives the exact location within the menus.</p> <p>Touch any of the underlined words to return to that menu or menu item.</p> <p>The Number of Copies is not underlined since this is the current screen. If you touch an underlined word on the Number of Copies screen before the Number of Copies is set and saved, then the selection is not saved, and it does not become the default setting.</p>
Attendance message alert 	If an attendance message occurs which affects a function, such as copy or fax, then a solid red exclamation point appears over the function button on the home screen, and the red indicator light blinks.

Additional printer setup

Installing internal options

 **CAUTION—SHOCK HAZARD:** If you are accessing the system board or installing optional hardware or memory devices sometime after setting up the printer, then turn the printer off, and unplug the power cord from the wall outlet before continuing. If you have any other devices attached to the printer, then turn them off as well, and unplug any cables going into the printer.

You can customize your printer connectivity and memory capacity by adding optional cards. The instructions in this section explain how to install the available cards; you can also use them to locate a card for removal.

Available internal options

- Memory cards
 - Printer memory
 - Flash memory
 - Fonts
- Firmware cards
 - Bar Code and Forms
 - IPDS and SCS/TNe
 - PrintCryptioTM
- Printer hard disk
- LexmarkTM Internal Solutions Ports (ISP)
 - RS-232-C Serial ISP
 - Parallel 1284-B ISP
 - MarkNetTM N8150 802.11 b/g/n Wireless ISP
 - MarkNet N8130 10/100 Fiber ISP
 - MarkNet N8120 10/100/1000 Ethernet ISP
- MarkNet N8110 V-34 Fax Card

Accessing the system board to install internal options

Note: This task requires a flathead screwdriver.

⚠ CAUTION—SHOCK HAZARD: If you are accessing the system board or installing optional hardware or memory devices sometime after setting up the printer, then turn the printer off, and unplug the power cord from the wall outlet before continuing. If you have any other devices attached to the printer, then turn them off as well, and unplug any cables going into the printer.

- 1 Loosen the screws on the back of the system board a quarter turn.

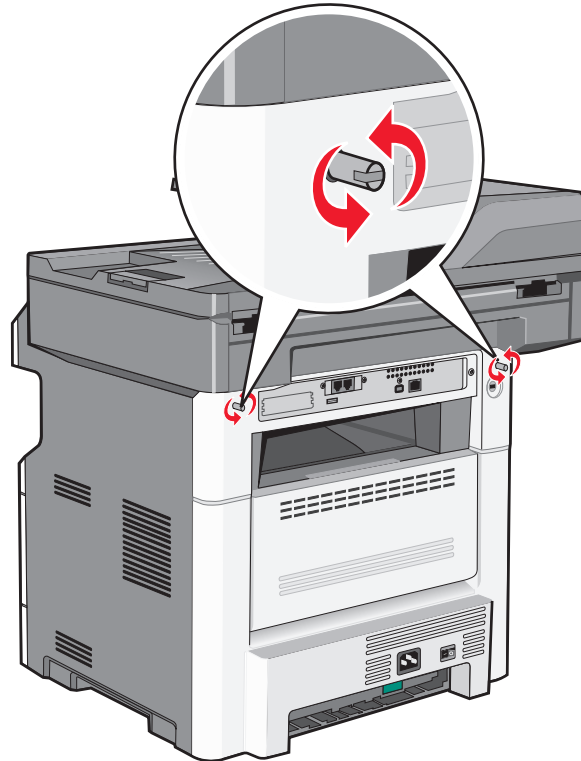

- Lift the front of the scanner unit to open the system board.

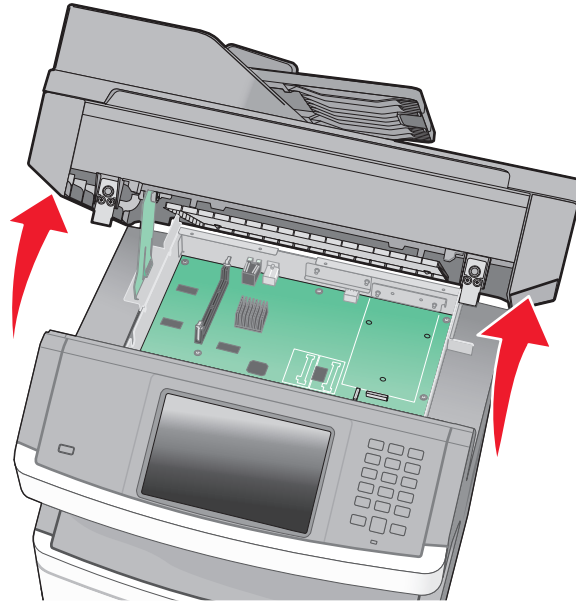

- Use the following illustration to locate the appropriate connector.

Warning—Potential Damage: System board electronic components are easily damaged by static electricity. Touch something metal on the printer before touching any system board electronic components or connectors.

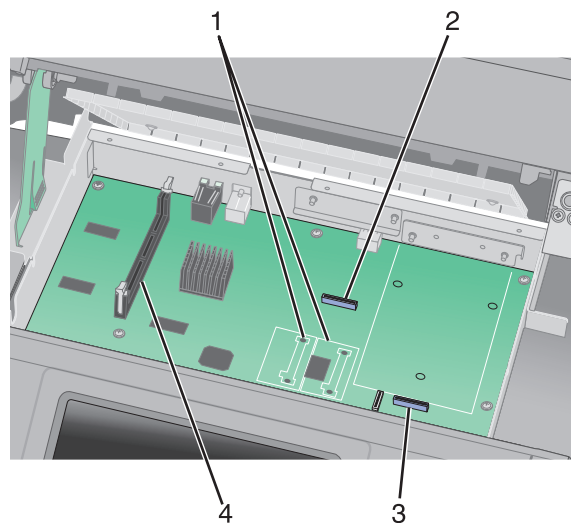

1	Flash memory or firmware card connectors
2	Fax card connector
3	Lexmark Internal Solutions Port or printer hard disk connector
4	Memory card connector

Installing a memory card

⚠ CAUTION—SHOCK HAZARD: If you are accessing the system board or installing optional hardware or memory devices sometime after setting up the printer, then turn the printer off, and unplug the power cord from the wall outlet before continuing. If you have any other devices attached to the printer, then turn them off as well, and unplug any cables going into the printer.

Warning—Potential Damage: System board electronic components are easily damaged by static electricity. Touch something metal on the printer before touching any system board electronic components or connectors.

Note: This task requires a flathead screwdriver.

An optional memory card can be purchased separately and attached to the system board. To install the memory card:

- 1 Access the system board.

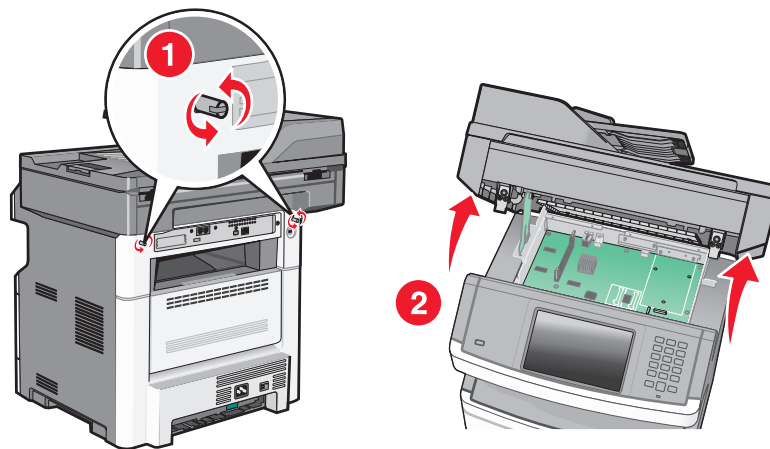

- 2 Unpack the memory card.

Note: Avoid touching the connection points along the edge of the card.

- 3 Open the memory card connector latches.

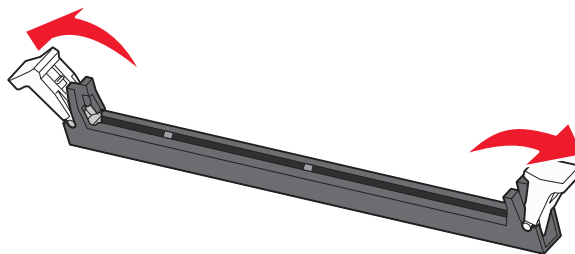

- 4 Align the notches on the memory card with the ridges in the connector.

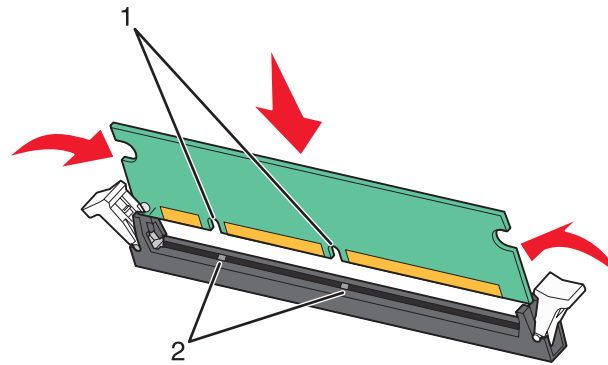

1	Notches
2	Ridges

- 5 Push the memory card straight into the connector until it *clicks* into place.

Note: After the memory card is installed, make sure the memory card connector latches return to the latched vertical position and are secure against the card.

- 6 Release the system board access latch, and then close the system board door by lowering the scanner.
7 Push in on the screws while rotating them clockwise a quarter turn to lock the system board into place.

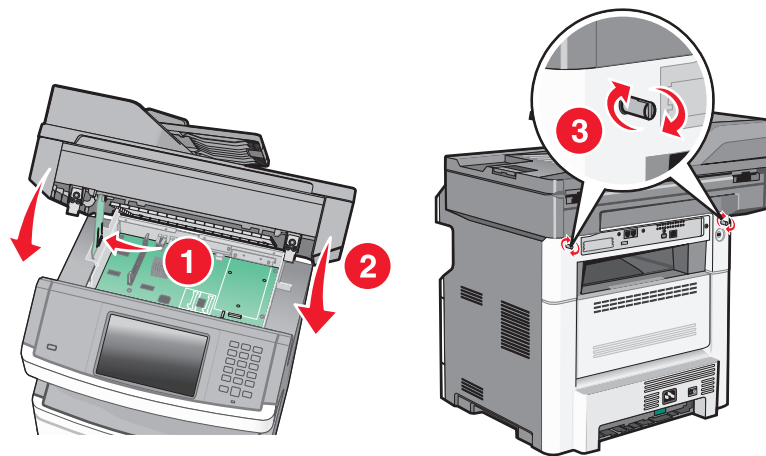

Warning—Potential Damage: Make sure the system board is locked to prevent possible damage to the printer if it is moved.

Installing a flash memory or firmware card

The system board has two connections for an optional flash memory or firmware card. Only one of each may be installed, but the connectors are interchangeable.

Note: This task requires a flathead screwdriver.

CAUTION—SHOCK HAZARD: If you are accessing the system board or installing optional hardware or memory devices sometime after setting up the printer, then turn the printer off, and unplug the power cord from the wall outlet before continuing. If you have any other devices attached to the printer, then turn them off as well, and unplug any cables going into the printer.

Warning—Potential Damage: System board electronic components are easily damaged by static electricity. Touch something metal on the printer before touching any system board electronic components or connectors.

- 1 Access the system board.

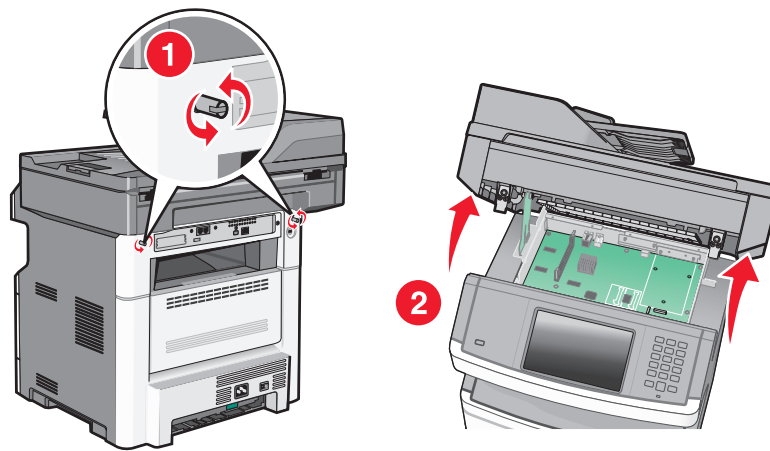

- 2 Unpack the card.

Note: Avoid touching any electrical components on the card.

3 Holding the card by its sides, align the plastic pins on the card with the holes on the system board.

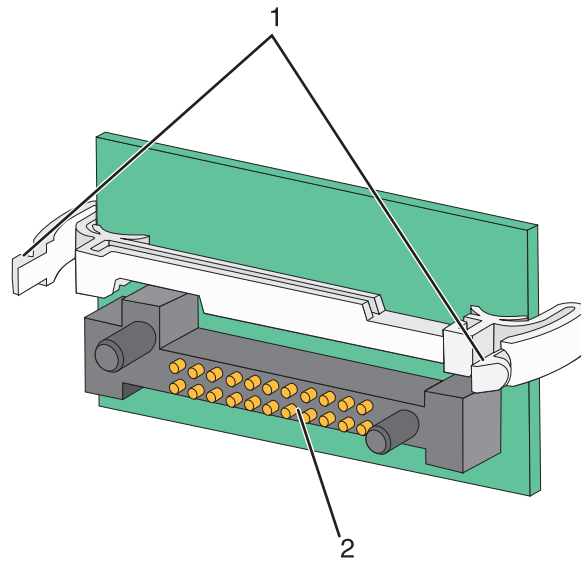

1	Plastic pins
2	Metal pins

4 Push the card firmly into place.

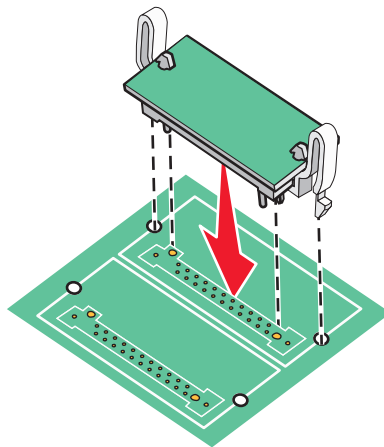

Notes:

- The entire length of the connector on the card must touch and be flush against the system board.
- Be careful not to damage the connectors.

5 Release the latch, and then close the system board door by lowering the scanner.

- 6 Push in on the screws while rotating them clockwise a quarter turn to lock the system board into place.

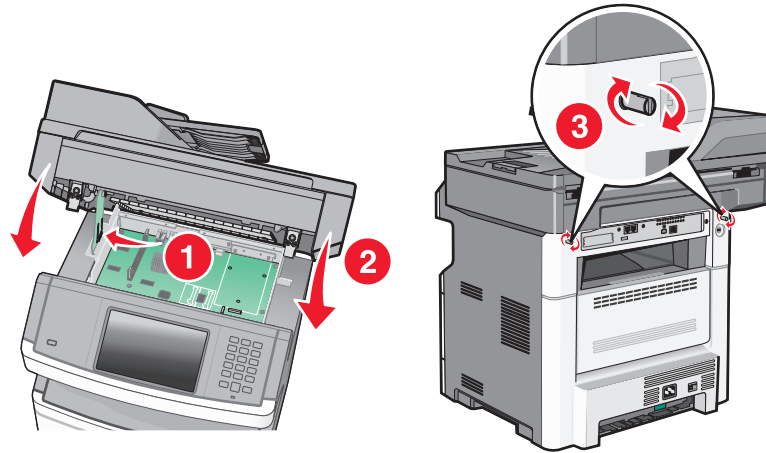

Warning—Potential Damage: Make sure the system board is locked to prevent possible damage to the printer if it is moved.

Installing an Internal Solutions Port

The system board supports one optional Lexmark Internal Solutions Port (ISP). Install an ISP for additional connectivity options.

Note: This task requires a #2 Phillips screwdriver and a flathead screwdriver.

CAUTION—SHOCK HAZARD: If you are accessing the system board or installing optional hardware or memory devices sometime after setting up the printer, then turn the printer off, and unplug the power cord from the wall outlet before continuing. If you have any other devices attached to the printer, then turn them off as well, and unplug any cables going into the printer.

Warning—Potential Damage: System board electronic components are easily damaged by static electricity. Touch something metal on the printer before touching any system board electronic components or connectors.

- 1 Access the system board.

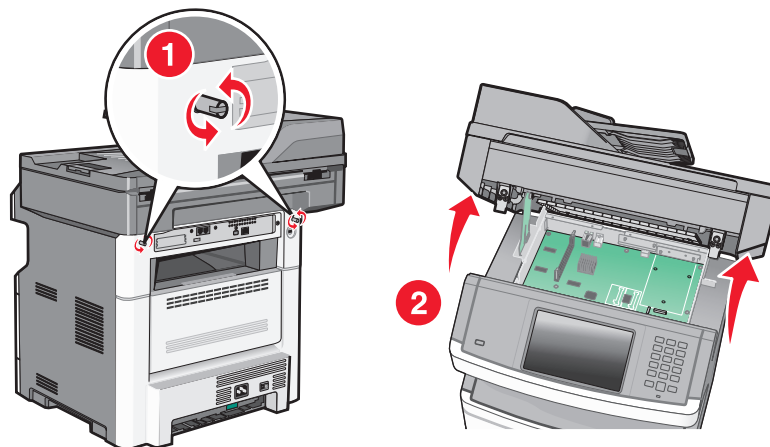

- 2 Unpack the ISP and plastic tee.

Note: Avoid touching the components on the card.

- 3 Locate the appropriate connector on the system board.

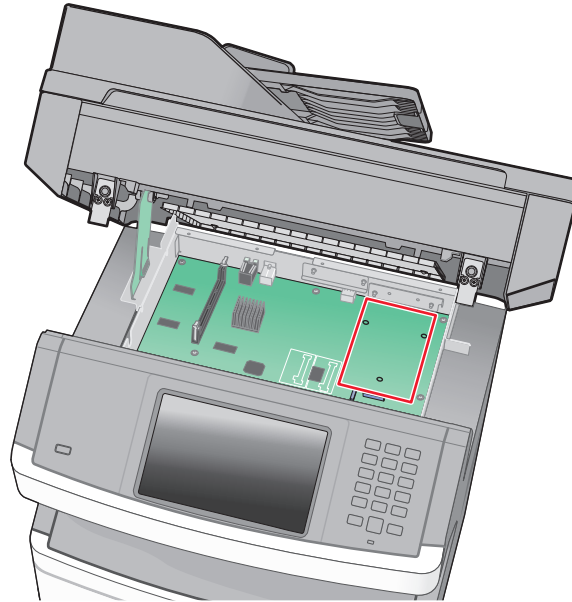

Note: If an optional printer hard disk is currently installed, then the printer hard disk must first be removed. To remove the hard disk:

- a Unplug the printer hard disk interface cable from the system board, leaving the cable attached to the printer hard disk. To unplug the cable, squeeze the paddle at the plug of the interface cable to disengage the latch before pulling the cable out.

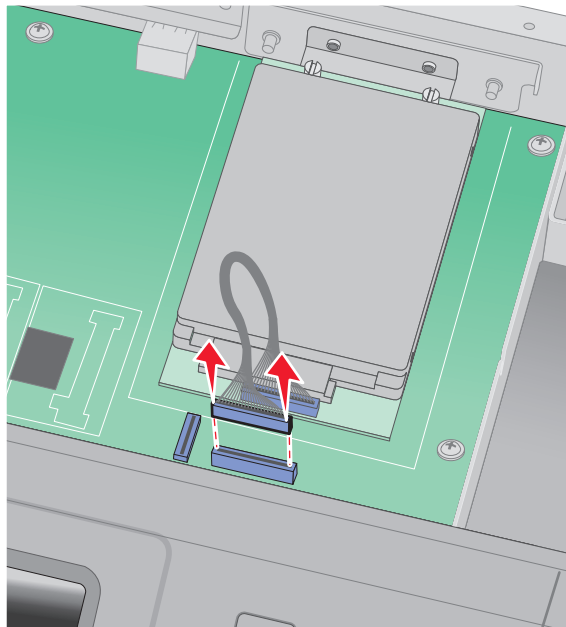

- b** Remove the screws holding the printer hard disk in place.

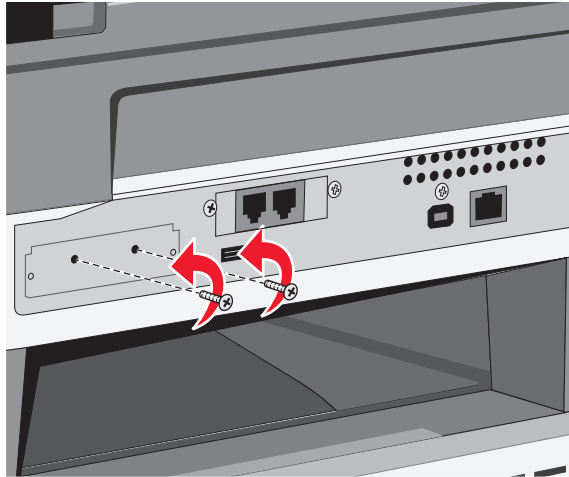

- c** Remove the printer hard disk by pulling it upward to unseat the standoffs.

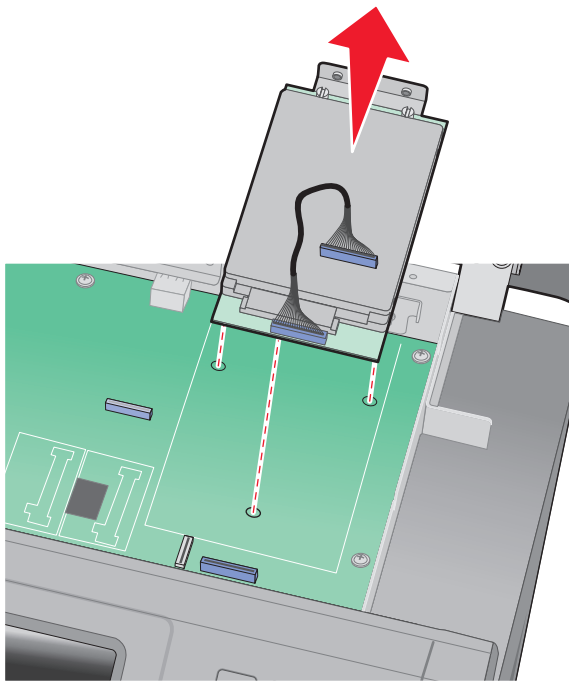

- d Remove the thumbscrews that attach the printer hard disk mounting bracket to the printer hard disk, and then remove the bracket. Set the printer hard disk aside.

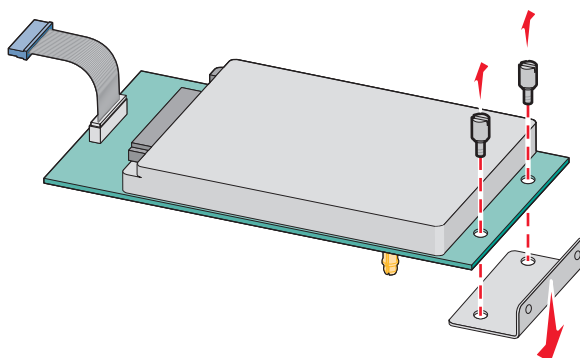

- 4 Remove the metal cover from the ISP opening.

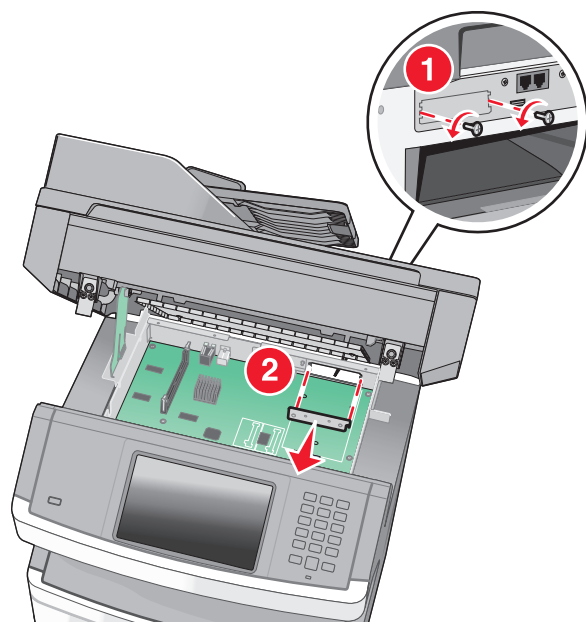

- 5** Align the posts of the plastic tee to the holes in the system board, and then press downward until the tee snaps into place. Be sure each post of the tee has latched completely, and that the tee is seated firmly onto the system board.

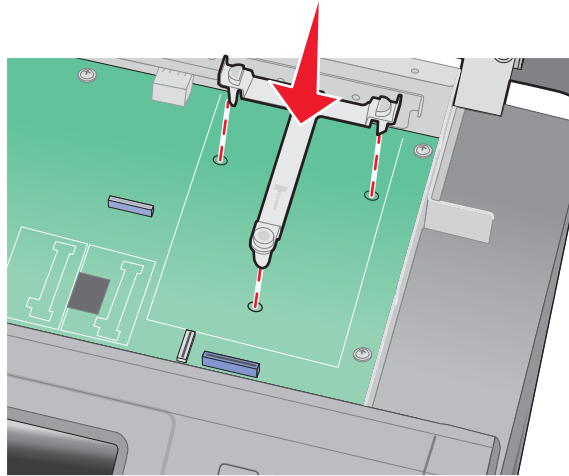

- 6** Install the ISP onto the plastic tee. Angle the ISP over the plastic tee, and then approach the plastic tee so that any overhanging connectors will pass through the ISP opening in the system board cage.

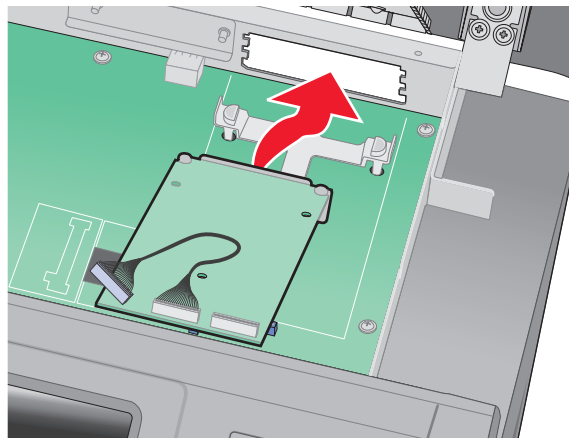

- 7** Lower the ISP toward the plastic tee until the ISP is seated between the guides of the plastic tee.

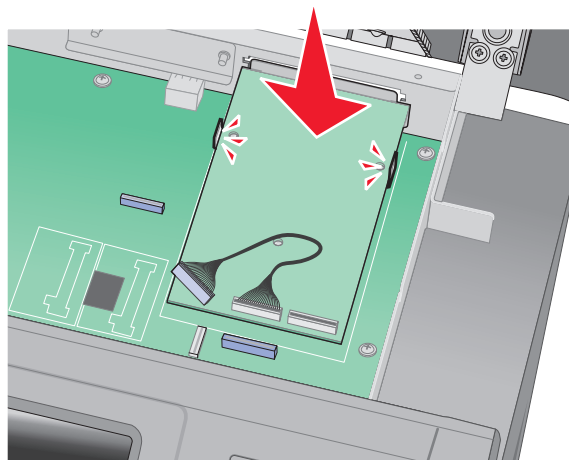

- 8** Insert the long thumbscrew, into the hole closest to the white connector, and turn it clockwise enough to hold the ISP in place. Do not tighten the thumbscrew at this time.

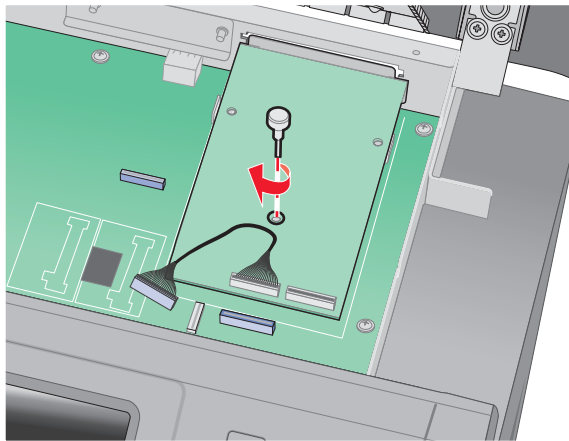

- 9** Attach the two provided screws to secure the ISP mounting bracket to the system board cage.

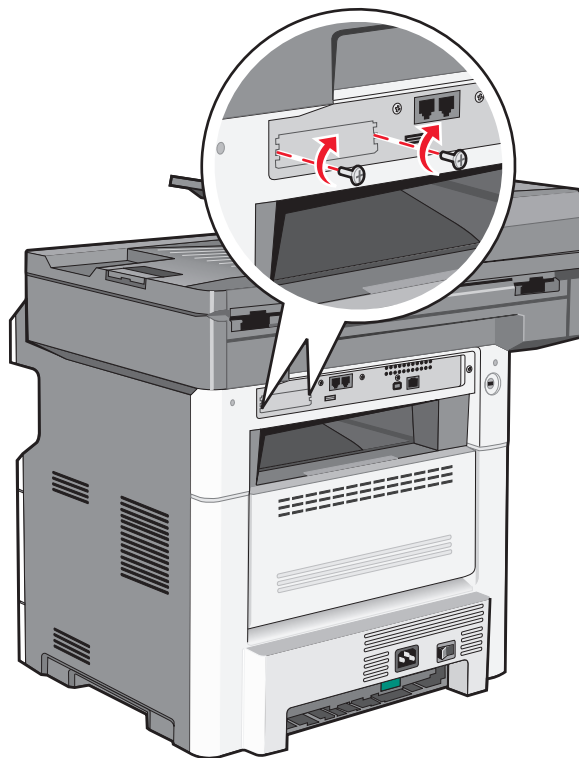

- 10** Tighten the long thumbscrew.

Note: Do not overtighten the thumbscrew.

- 11** Insert the plug of the ISP interface cable into the receptacle of the system board.

Note: The plugs and receptacles are color coded.

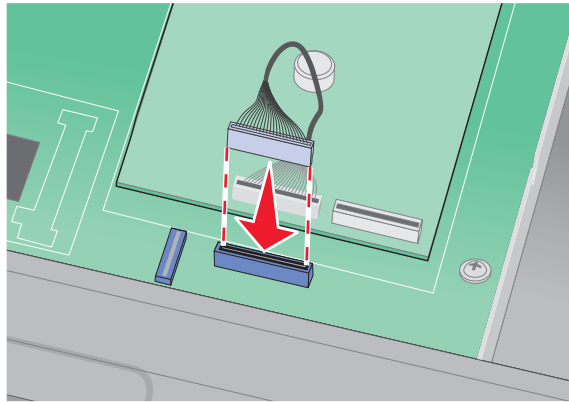

- 12** If a printer hard disk was previously installed, then attach the printer hard disk to the ISP. For more information, see “Installing a printer hard disk” on page 42.
- 13** Release the latch, and then close the system board door by lowering the scanner.
- 14** Push in on the screws while rotating them clockwise a quarter turn to lock the system board into place.

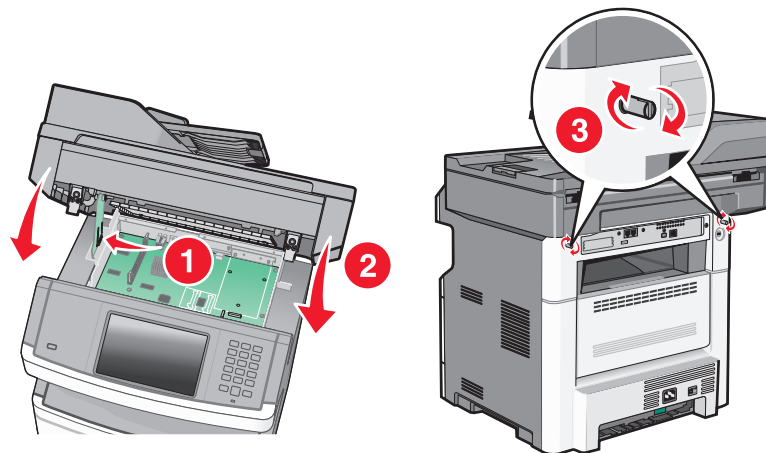

Warning—Potential Damage: Make sure the system board is locked to prevent possible damage to the printer if it is moved.

Installing a printer hard disk

The optional printer hard disk can be installed with or without a Lexmark Internal Solutions Port (ISP).

Note: This task requires a #2 Phillips screwdriver and a flathead screwdriver.

CAUTION—SHOCK HAZARD: If you are accessing the system board or installing optional hardware or memory devices sometime after setting up the printer, then turn the printer off, and unplug the power cord from the wall outlet before continuing. If you have any other devices attached to the printer, then turn them off as well, and unplug any cables going into the printer.

Warning—Potential Damage: System board electronic components are easily damaged by static electricity. Touch something metal on the printer before touching any system board electronic components or connectors.

- 1 Access the system board.

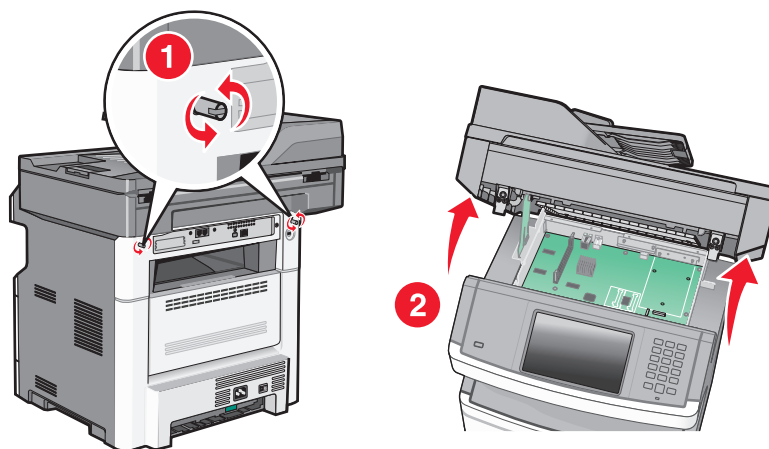

- 2 Unpack the printer hard disk.

Note: Avoid touching the components on the card.

- 3 Locate the appropriate connector on the system board.

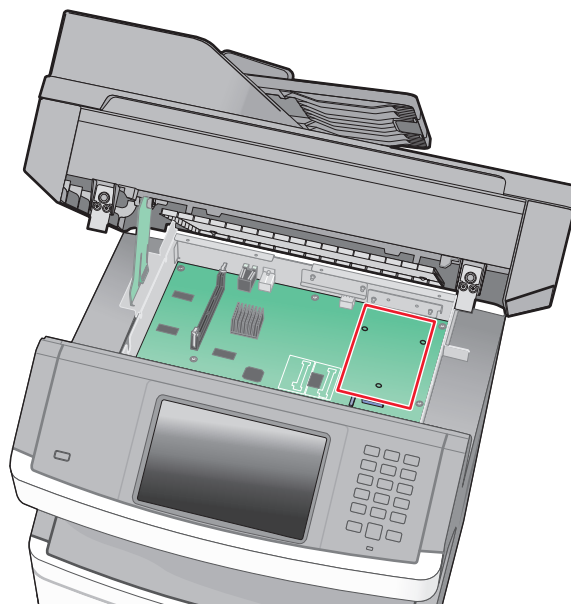

Note: If an optional ISP is currently installed, then the printer hard disk must be installed onto the ISP.

To install a printer hard disk onto the ISP:

- a** Using a flathead screwdriver to loosen the screws, remove the thumbscrews that attach the printer hard disk mounting bracket to the printer hard disk, and then remove the bracket.

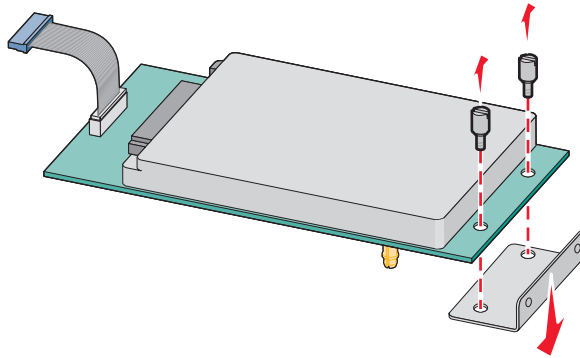

- b** Align the standoffs of the printer hard disk with the holes in the ISP, and then press downward on the printer hard disk until the standoffs have seated into place.

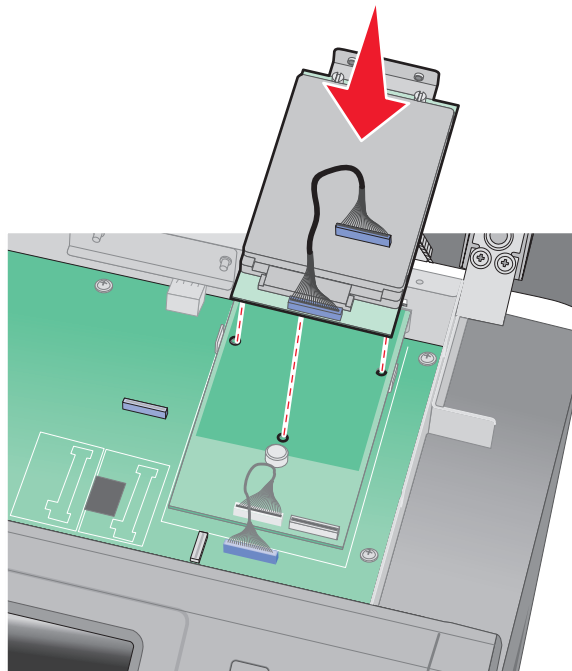

- c** Insert the plug of the printer hard disk interface cable into the receptacle of the ISP.

Note: The plugs and receptacles are color coded.

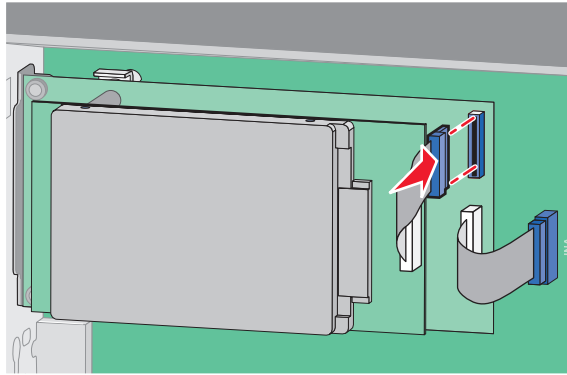

To install a printer hard disk directly onto the system board:

- a** Align the standoffs of the printer hard disk with the holes in the system board, and then press downward on the printer hard disk until the standoffs have seated into place.

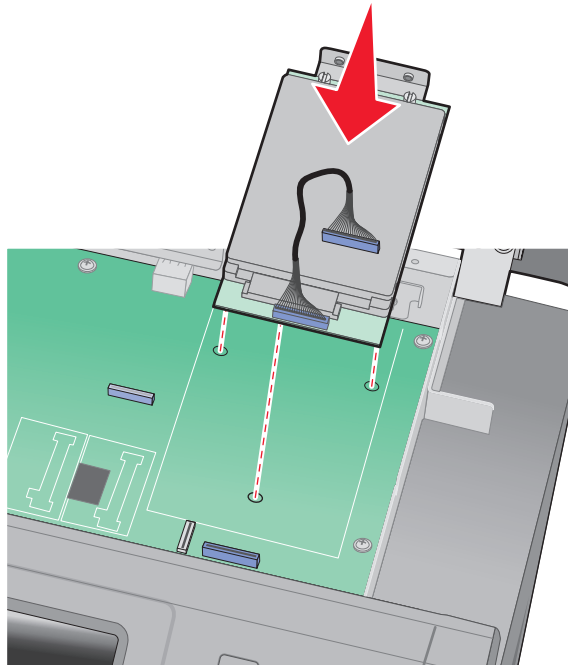

- b** Attach the two provided screws to secure the printer hard disk mounting bracket.

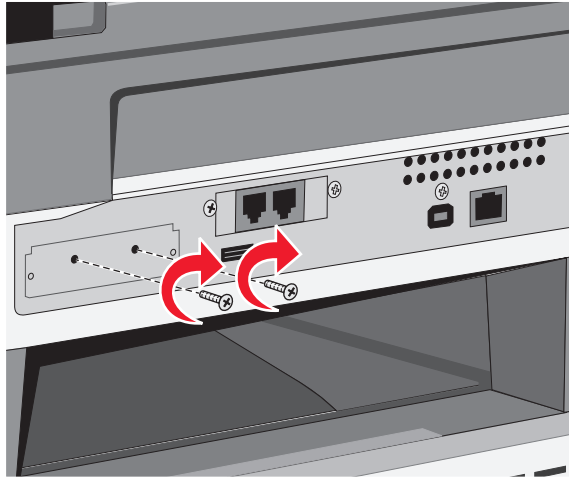

- c** Insert the plug of the printer hard disk interface cable into the receptacle of the system board.

Note: The plugs and receptacles are color coded.

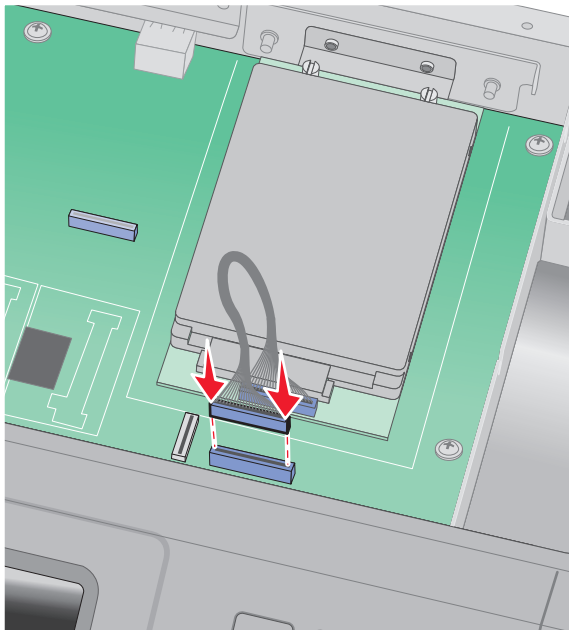

- 4** Release the latch, and then close the system board door by lowering the scanner.

- 5 Push in on the screws while rotating them clockwise a quarter turn to lock the system board into place.

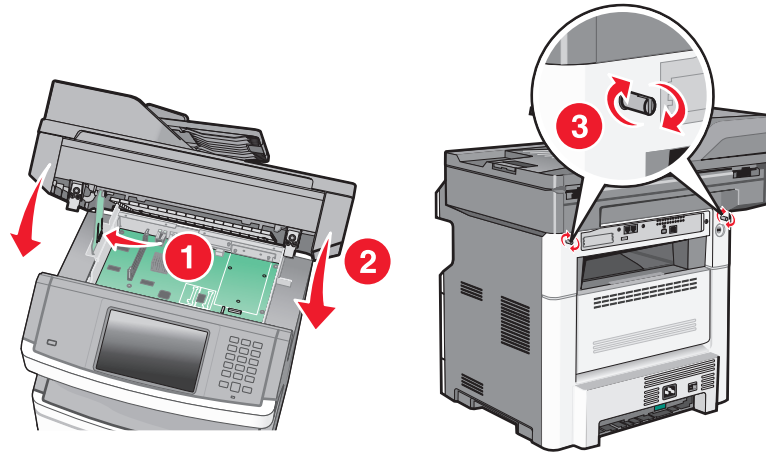

Warning—Potential Damage: Make sure the system board is locked to prevent possible damage to the printer if it is moved.

Installing a fax card

Note: This task requires a #2 Phillips screwdriver and a flathead screwdriver.

CAUTION—SHOCK HAZARD: If you are accessing the system board or installing optional hardware or memory devices sometime after setting up the printer, then turn the printer off, and unplug the power cord from the wall outlet before continuing. If you have any other devices attached to the printer, then turn them off as well, and unplug any cables going into the printer.

Warning—Potential Damage: System board electronic components are easily damaged by static electricity. Touch something metal on the printer before touching any system board electronic components or connectors.

- 1 Access the system board.

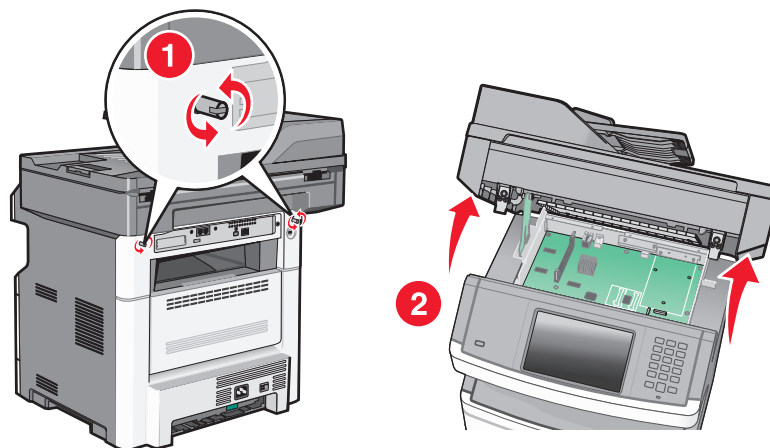

- 2 Unpack the fax card.

- 3 Remove the metal cover from the fax card opening.

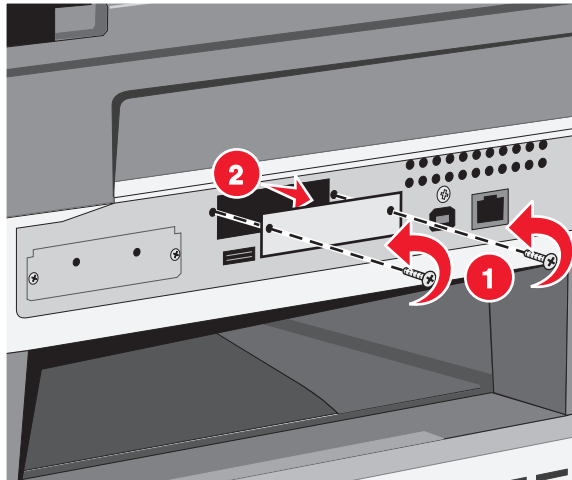

- 4 Insert the fax card, and then tighten the two screws to secure the fax card mounting bracket.

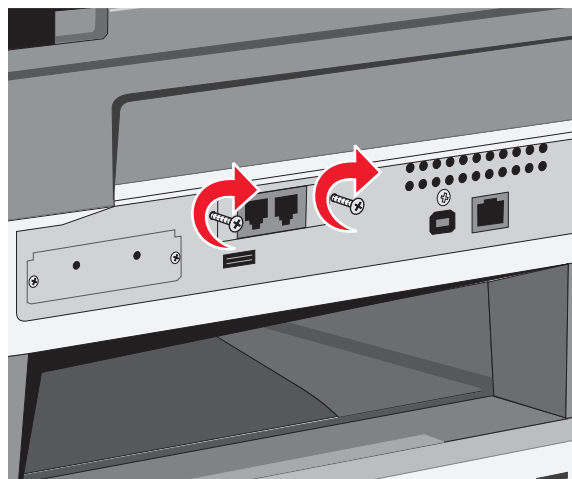
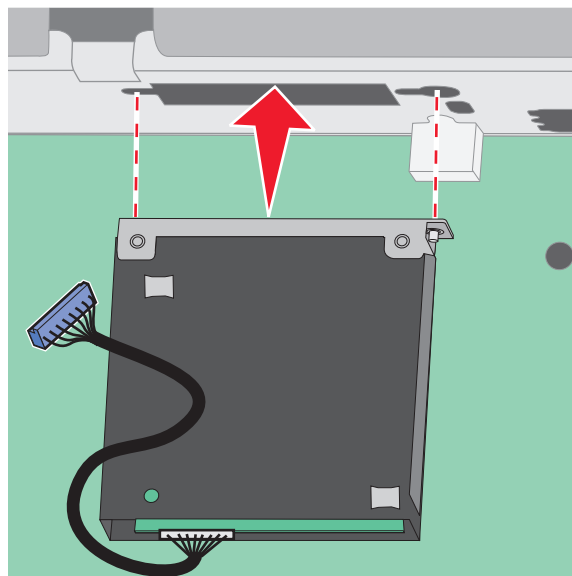

- 5 Insert the plug of the fax card interface cable into the receptacle of the system board.

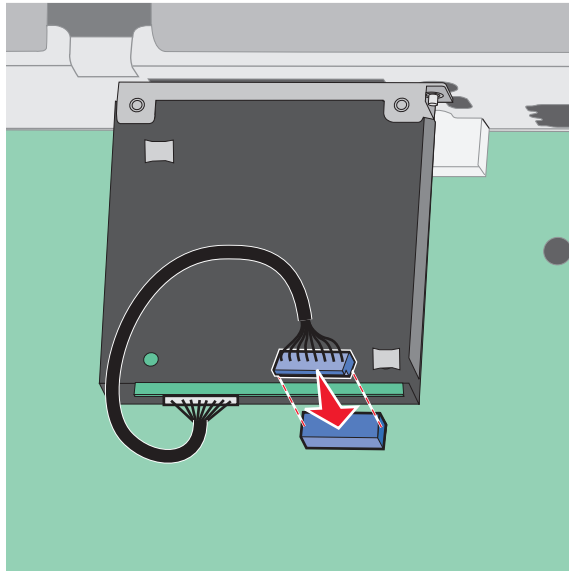

- 6 Release the latch, and then close the system board door by lowering the scanner.
- 7 Push in on the screws while rotating them clockwise a quarter turn to lock the system board into place.

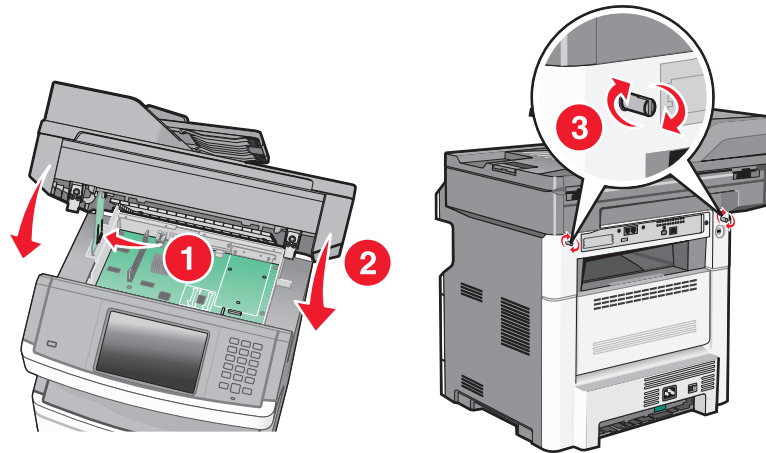

Warning—Potential Damage: Make sure the system board is locked to prevent possible damage to the printer if it is moved.

Installing hardware options

Installing a 250- or 550-sheet drawer

The printer supports one optional drawer; you can install a 250- or 550-sheet drawer.

⚠ CAUTION—SHOCK HAZARD: If you are accessing the system board or installing optional hardware or memory devices sometime after setting up the printer, then turn the printer off, and unplug the power cord from the wall outlet before continuing. If you have any other devices attached to the printer, then turn them off as well, and unplug any cables going into the printer.

- 1 Unpack the drawer, and then remove any packing material from the outside of the drawer.
- 2 Remove the tray from the support unit.

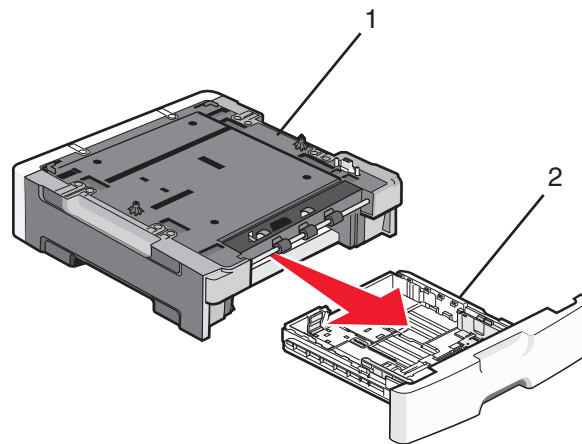

1	Support unit
2	Tray

- 3 Remove any packing material and tape from inside the tray.
- 4 Insert the tray into the support unit.
- 5 Place the drawer in the location chosen for the printer.

6 Align the printer with the drawer, and then lower the printer into place.

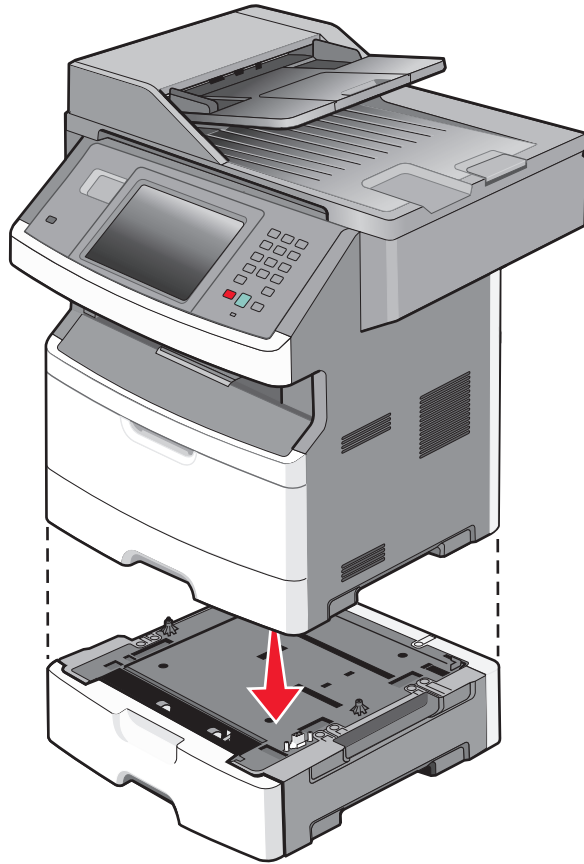

Attaching cables

Connect the printer to the computer using a USB cable, or to the network using an Ethernet cable.

Be sure to match the following:

- The USB symbol on the cable with the USB symbol on the printer
- The appropriate Ethernet cable to the Ethernet port

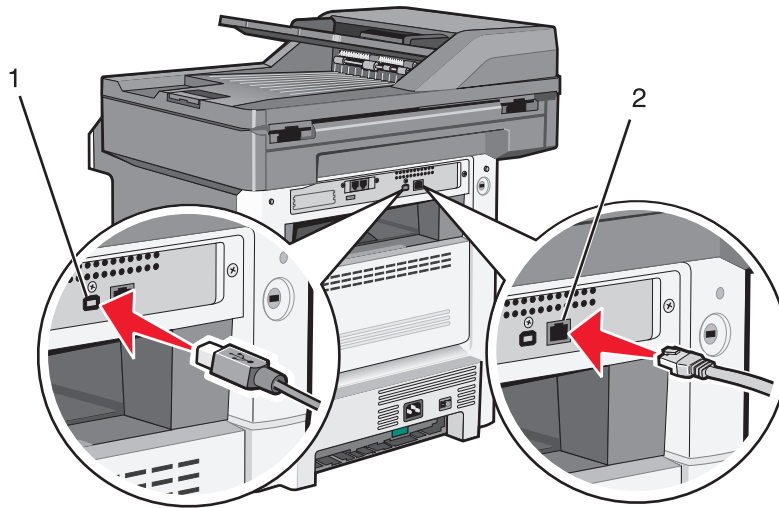

1	USB port
2	Ethernet port

Verifying printer setup

Once all hardware and software options are installed and the printer is turned on, verify that the printer is set up correctly by printing the following:

- **Menu settings page**—Use this page to verify that all printer options are installed correctly. A list of installed options appears toward the bottom of the page. If an option you installed is not listed, then it is not installed correctly. Remove the option and install it again.
- **Network setup page**—If your printer is a network model and is attached to a network, print a network setup page to verify the network connection. This page also provides important information that aids network printing configuration.

Printing a menu settings page

Print a menu settings page to review the current menu settings and to verify printer options are installed correctly.

Note: If you have not made any menu item settings changes yet, then the menu settings page lists all the factory default settings. Once you select and save other settings from the menus, they replace the factory default settings as *user default settings*. A user default setting remains in effect until you access the menu again, choose another value, and save it. To restore the factory default settings, see “Restoring the factory default settings” on page 238.

- 1 Make sure the printer is on and **Ready** appears.
- 2 On the home screen, touch .
- 3 Touch **Reports**.
- 4 Touch **Menu Settings Page**.

The menu settings page prints and the printer returns to the home screen.

Printing a network setup page

If the printer is attached to a network, then print a network setup page to verify the network connection. This page also provides important information that aids network printing configuration.

1 Make sure the printer is on and **Ready** appears.

2 On the home screen, touch .

3 Touch **Reports**.

4 Touch **Network Setup Page**.

The network setup page prints and the printer returns to the home screen.

5 Check the first section on the network setup page, and confirm that Status is “Connected.”

If Status is “Not Connected,” then the LAN drop may not be active, the network cable may be malfunctioning, or, if you have a wireless printer model, the wireless network may not be configured properly. Consult a system support person for a solution, and then print another network setup page.

Setting up the printer software

Installing printer software

A printer driver is software that lets the computer communicate with the printer. The printer software is typically installed during the initial printer setup. If you need to install the software after setup, follow these instructions:

For Windows users

- 1** Close all open software programs.
- 2** Insert the *Software and Documentation* CD.
- 3** From the main installation dialog, click **Install**.
- 4** Follow the instructions on the screen.

For Macintosh users

- 1** Close all open software applications.
- 2** Insert the *Software and Documentation* CD.
- 3** From the Finder desktop, double-click the printer CD icon that automatically appears.
- 4** Double-click the **Install** icon.
- 5** Follow the instructions on the screen.

Using the World Wide Web

- 1** Go to the Lexmark Web site at www.lexmark.com.
- 2** From the Drivers & Downloads menu, click **Driver Finder**.
- 3** Select your printer, and then select your operating system.
- 4** Download the driver and install the printer software.

Updating available options in the printer driver

Once the printer software and any options are installed, it may be necessary to manually add the options in the printer driver to make them available for print jobs.

For Windows users

- 1 Click , or click **Start** and then click **Run**.
- 2 In the Start Search or Run box, type **control printers**.
- 3 Press **Enter**, or click **OK**.
The printer folder opens.
- 4 Select the printer.
Note: If the printer has a fax option, choose the appropriate printer model with the letters "PS."
- 5 Right-click the printer, and then select **Properties**.
- 6 Click the **Install Options** tab.
- 7 Under Available Options, add any installed hardware options.
Note: If the printer has a fax option, select **Fax**, and then add it as an installed option.
- 8 Click **Apply**.

For Macintosh users

In Mac OS X version 10.5 or later

- 1 From the Apple menu, choose **System Preferences**.
- 2 Click **Print & Fax**.
- 3 Select the printer, and then click **Options & Supplies**.
- 4 Click **Driver**, and then add any installed hardware options.
- 5 Click **OK**.

In Mac OS X version 10.4 and earlier

- 1 From the Finder desktop, choose **Go > Applications**.
- 2 Double-click **Utilities**, and then double-click **Print Center** or **Printer Setup Utility**.
- 3 Select the printer, and then from the Printers menu, choose **Show Info**.
- 4 From the pop-up menu, choose **Installable Options**.
- 5 Add any installed hardware options, and then click **Apply Changes**.

Setting up wireless printing

Note: Wireless printing is not standard on all printer models.

Follow these steps to set up your printer



Note: Do not connect cables until instructed to do so.

- 1 Set up the printer hardware. For more information, see the *Setup Guide*.
- 2 Follow the instructions for your operating system:
 - **Windows**—See “Information you will need to set up the printer on a wireless network” on page 54 and “Installing the printer on a wireless network (Windows)” on page 55.
 - **Macintosh**—See “Information you will need to set up the printer on a wireless network” on page 54 and “Installing the printer on a wireless network (Macintosh)” on page 58.

Information you will need to set up the printer on a wireless network

Note: Do not connect the installation or network cables until prompted to do so by the setup software.

- **SSID**—The SSID is also referred to as the network name.
- **Wireless Mode (or Network Mode)**—The mode will be either infrastructure or ad hoc.
- **Channel (for ad hoc networks)**—The channel defaults to auto for infrastructure networks.

Some ad hoc networks will also require the auto setting. Check with your system support person if you are not sure which channel to select.

- **Security Method**—There are three basic options for Security Method:
 - WEP key
 - If your network uses more than one WEP key, enter up to four in the provided spaces. Select the key currently in use on the network by selecting the Default WEP Transmit Key.
 - or
 - WPA or WPA2 passphrase
 - WPA includes encryption as an additional layer of security. The choices are AES or TKIP. Encryption must be set for the same type on the router and on the printer, or the printer will not be able to communicate on the network.

– No security

If your wireless network does not use any type of security, then you will not have any security information.

Note: Using an unsecured wireless network is not recommended.

If you are installing the printer on an 802.1X network using the Advanced method, then you may need the following:

- Authentication type
- Inner authentication type
- 802.1X username and password
- Certificates

Note: For more information on configuring 802.1X security, see the *Networking Guide on the Software and Documentation CD*.

Installing the printer on a wireless network (Windows)

Before you install the printer on a wireless network, make sure that:

- A wireless card is installed in your printer.
- Your wireless network is set up and working properly.
- The computer you are using is connected to the same wireless network where you want to set up the printer.

- 1 Connect the power cable to the printer and then to a properly grounded electrical outlet, and then turn the printer on.

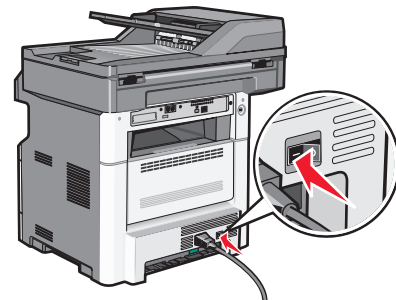
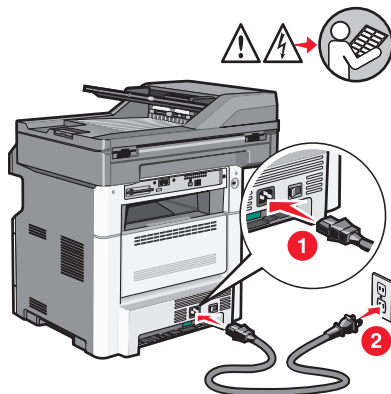

Make sure the printer and computer are fully on and ready.



Do not connect the USB cable until instructed to do so on the screen.

- 2 From the printer control panel, select your language and country or region, and then touch **Continue**.
- 3 Select your time zone, and then touch **Continue**.
- 4 Deselect any function you plan to set up later, such as Fax or E-mail, and then touch **Continue**.

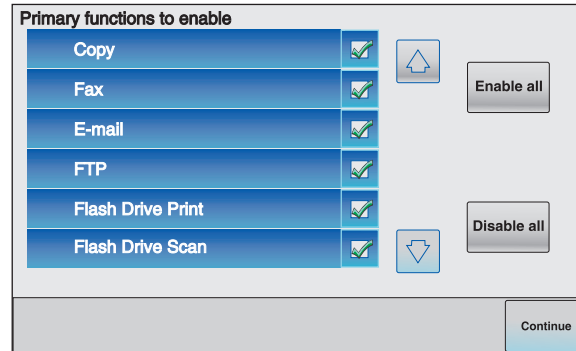

- 5 Select any additional buttons you want to display on the home screen, and then touch **Continue**.

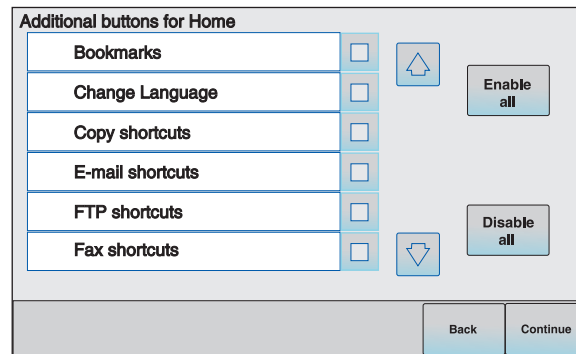

- 6 If Fax is enabled, then type in your Fax Station name and touch **Enter**. For more information on fax station name and number, see your system support person; or touch **Back** to go back and deselect **Fax**.
- 7 If Fax is enabled, enter the Fax station (phone) number for this printer, and then touch **Continue**.
- 8 If E-mail is enabled, type in the Primary SMTP (mail server) Gateway address, and then touch **Enter**. For more information on enabling e-mail, see your system support person; or touch **Back** to go back and deselect **E-mail**.
- 9 If prompted, set the date and time, and then touch **Continue**.
- 10 Insert the *Software and Documentation* CD.

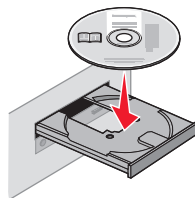

- 11 Click **Install Printer and Software**.
- 12 Click **Agree** to agree to the License Agreement.
- 13 Select **Suggested**, and then click **Next**.
- 14 Click **Wireless Network Attach**.

- 15** Remove the label covering the USB port on the back of the printer.

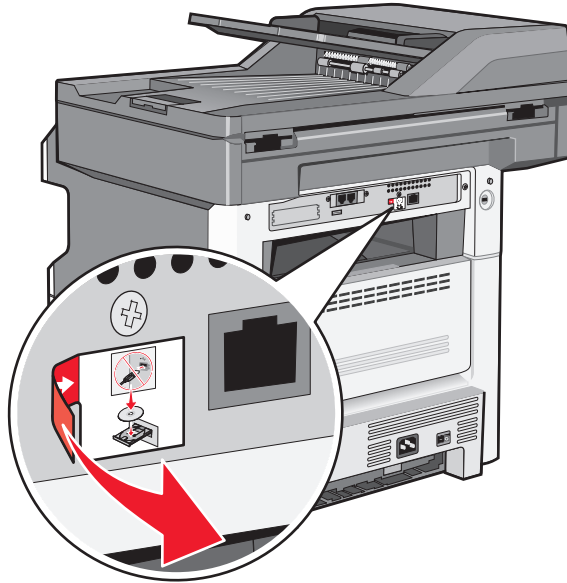

- 16** Connect the cables in the following order:

- a** Temporarily connect a USB cable between the computer on the wireless network and the printer.

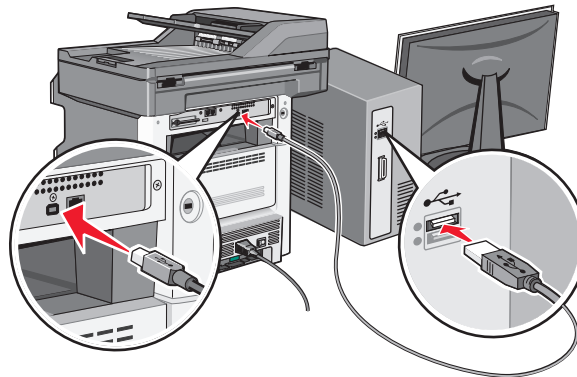

Note: After the printer is configured, the software will instruct you to disconnect the temporary USB cable so you can print wirelessly.

- b** If you plan to set up fax now, then connect the fax cables. See the *User's Guide on the Software and Documentation* CD for help deciding how to connect the cables.

- 17** Follow the on-screen instructions to complete the software installation.

Note: **Basic** is the recommended path to choose. Choose **Advanced** only if you want to customize your installation or if your network uses 802.1x security.

- 18** To allow other computers on the wireless network to use the wireless printer, follow steps 10 through 14 for each computer.

Installing the printer on a wireless network (Macintosh)

Before you install the printer on a wireless network, make sure that:

- A wireless card is installed in your printer.
- Your wireless network is set up and working properly.
- The computer you are using is connected to the same wireless network where you want to set up the printer.

Prepare to configure the printer

- 1 Locate the printer MAC address on the sheet that came with the printer. Write the last six digits of the MAC address in the space provided:

MAC address: _____

- 2 Connect the power cable to the printer and then to a properly grounded electrical outlet, and then turn the printer on.

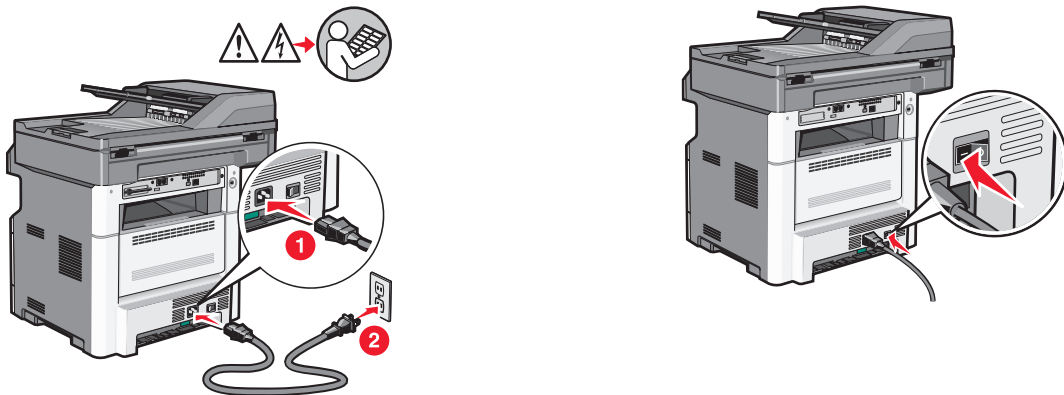

- 3 From the printer control panel, select your language and country or region, and then touch **Continue**.
- 4 Select your time zone, and then touch **Continue**.
- 5 Deselect any function you plan to set up later, such as Fax or E-mail, and then touch **Continue**.

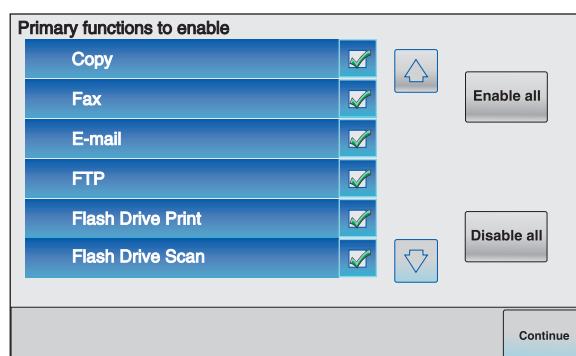

- 6 Select any additional buttons you want to display on the home screen, and then touch **Continue**.

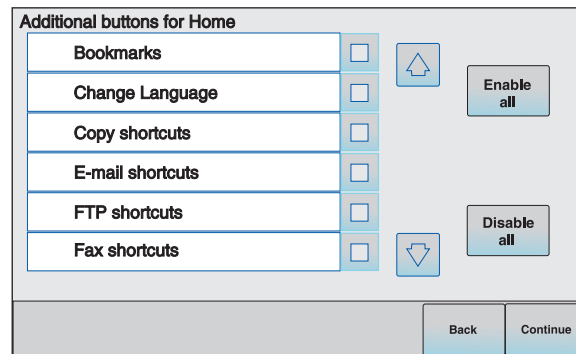

- 7 If Fax is enabled, type in your Fax Station name, and then touch **Enter**. For more information on fax station name and number, see your system support person; or touch **Back** to go back and deselect **Fax**.
- 8 If Fax is enabled, enter the Fax station (phone) number for this printer, and then touch **Continue**.
- 9 If E-mail is enabled, type in the Primary SMTP (mail server) Gateway address, and then touch **Enter**. For more information on enabling e-mail, see your system support person; or touch **Back** to go back and deselect **E-mail**.
- 10 If prompted, set the date and time, and then touch **Continue**.

Enter the printer information

- 1 Access the AirPort options.

In Mac OS X version 10.5 or later

- a From the Apple menu, choose **System Preferences**.
- b Click **Network**.
- c Click **AirPort**.

In Mac OS X version 10.4 and earlier

- a From the Finder desktop, choose **Go >Applications**.
- b From the Applications folder, double-click **Internet Connect**.
- c From the toolbar, click **AirPort**.

- 2 From the Network pop-up menu, select **print server xxxxxx**, where the x's are the last six digits of the MAC address located on the MAC address sheet.
- 3 Open the Safari browser.
- 4 From the Bookmarks drop-down menu, select **Show**.
- 5 Under Collections, select **Bonjour** or **Rendezvous**, and then double-click the printer name.

Note: The application is referred to as *Rendezvous* in Mac OS X version 10.3, but is now called *Bonjour* by Apple Computer.

- 6 From the main page of the Embedded Web Server, navigate to the page where the wireless settings information is stored.

Configure the printer for wireless access

- 1 Type the name of your network (SSID) in the appropriate field.
- 2 Select **Infrastructure** as your Network Mode if you are using a wireless router.
- 3 Select the type of security you use to protect your wireless network.
- 4 Enter the security information necessary for the printer to join your wireless network.
- 5 Click **Submit**.
- 6 Open the AirPort application on your computer:

In Mac OS X version 10.5 or later

- a From the Apple menu, choose **System Preferences**.
- b Click **Network**.
- c Click **AirPort**.

In Mac OS X version 10.4 and earlier

- a From the Finder desktop, choose **Go >Applications**.
- b From the Applications folder, double-click **Internet Connect**.
- c From the toolbar, click **AirPort**.

- 7 From the Network pop-up menu, select your wireless network.

Configure your computer to use the printer wirelessly

To print to a network printer, each Macintosh user must install a custom *PostScript Printer Description* (PPD) file and create a printer in the Print Center or Printer Setup Utility.

- 1 Install a PPD file on the computer:
 - a Insert the *Software and Documentation* CD in the CD or DVD drive.
 - b Double-click the installer package for the printer.
 - c From the Welcome screen, click **Continue**.
 - d Click **Continue** again after viewing the Readme file.
 - e Click **Continue** after viewing the license agreement, and then click **Agree** to accept the terms of the agreement.
 - f Select a Destination, and then click **Continue**.
 - g From the Easy Install screen, click **Install**.
 - h Type the user password, and then click **OK**.
All necessary software is installed on the computer.
 - i Click **Restart** when installation is complete.
- 2 Add the printer:
 - a For IP printing:
 - In Mac OS X version 10.5 or later
 - 1 From the Apple menu, choose **System Preferences**.
 - 2 Click **Print & Fax**.
 - 3 Click +.

- 4 Select the printer from the list.
- 5 Click **Add**.

In Mac OS X version 10.4

- 1 From the Finder desktop, choose **Go >Applications**.
- 2 Double-click the **Utilities** folder.
- 3 Double-click **Printer Setup Utility** or **Print Center**.
- 4 From the Printer List, choose **Add**.
- 5 Select the printer from the list.
- 6 Click **Add**.

b For AppleTalk printing:

In Mac OS X version 10.5

- 1 From the Apple menu, choose **System Preferences**.
- 2 Click **Print & Fax**.
- 3 Click **+**.
- 4 Click **AppleTalk**.
- 5 Select the printer from the list.
- 6 Click **Add**.

In Mac OS X version 10.4

- 1 From the Finder desktop, choose **Go >Applications**.
- 2 Double-click the **Utilities** folder.
- 3 Double-click **Print Center** or **Printer Setup Utility**.
- 4 From the Printer List, choose **Add**.
- 5 Choose the **Default Browser** tab.
- 6 Click **More Printers**.
- 7 From the first pop-up menu, choose **AppleTalk**.
- 8 From the second pop-up menu, select **Local AppleTalk zone**.
- 9 Select the printer from the list.
- 10 Click **Add**.

Installing the printer on a wired network

Use the following instructions to install the printer on a wired network. These instructions apply to Ethernet and fiber optic network connections.

Before you install the printer on a wired network, make sure that:

- You have completed the initial setup of the printer.
- The printer is connected to your network with the appropriate type of cable.

For Windows users

- 1 Insert the *Software and Documentation* CD.
Wait for the Welcome screen to appear.

If the CD does not launch after a minute, then do the following:

- a Click , or click **Start** and then click **Run**.
- b In the Start Search or Run box, type **D:\setup.exe**, where **D** is the letter of your CD or DVD drive.

2 Click **Install Printer and Software**.

3 Click **Agree** to agree to the License Agreement.

4 Select **Suggested**, and then click **Next**.

Note: To configure the printer using a static IP address, using IPv6, or to configure printers using scripts, select **Custom** and follow the on-screen instructions.

5 Select **Wired Network Attach**, and then click **Next**.

6 Select the printer manufacturer from the list.

7 Select the printer model from the list, and then click **Next**.

8 Select the printer from the list of printers discovered on the network, and then click **Finish**.

Note: If your configured printer does not appear in the list of discovered printers, click **Add Port** and follow the on-screen instructions.

9 Follow the on-screen instructions to complete the installation.

For Macintosh users

1 Allow the network DHCP server to assign an IP address to the printer.

2 Print the network setup page from the printer. For information on printing a network setup page, see “Printing a network setup page” on page 52.

3 Locate the printer IP address in the TCP/IP section of the network setup page. You will need the IP address if you are configuring access for computers on a different subnet than the printer.

4 Install the drivers and add the printer.

a Install a PPD file on the computer:

1 Insert the *Software and Documentation* CD in the CD or DVD drive.

2 Double-click the installer package for the printer.

3 From the Welcome screen, click **Continue**.

4 Click **Continue** again after viewing the Readme file.

5 Click **Continue** after viewing the license agreement, and then click **Agree** to accept the terms of the agreement.

6 Select a Destination, and then click **Continue**.

7 From the Easy Install screen, click **Install**.

8 Type the user password, and then click **OK**.

All the necessary software is installed on the computer.

9 Click **Restart** when installation is complete.

b Add the printer:

- For IP printing:

In Mac OS X version 10.5 or later

- 1 From the Apple menu, choose **System Preferences**.
- 2 Click **Print & Fax**.
- 3 Click **+**.
- 4 Click **IP**.
- 5 Type in the IP address of your printer in the Address field.
- 6 Click **Add**.

In Mac OS X version 10.4 and earlier

- 1 From the Finder desktop, choose **Go > Applications**.
- 2 Double-click **Utilities**.
- 3 Double-click **Printer Setup Utility** or **Print Center**.
- 4 From the Printer List, click **Add**.
- 5 Click **IP**.
- 6 Type in the IP address of your printer in the Address field.
- 7 Click **Add**.

- For AppleTalk printing:

In Mac OS X version 10.5

- 1 From the Apple menu, choose **System Preferences**.
- 2 Click **Print & Fax**.
- 3 Click **+**.
- 4 Click **AppleTalk**.
- 5 Select the printer from the list.
- 6 Click **Add**.

In Mac OS X version 10.4 and earlier

- 1 From the Finder desktop, choose **Go > Applications**.
- 2 Double-click **Utilities**.
- 3 Double-click **Print Center** or **Printer Setup Utility**.
- 4 From the Printer List, click **Add**.
- 5 Choose the **Default Browser** tab.
- 6 Click **More Printers**.
- 7 From the first pop-up menu, choose **AppleTalk**.
- 8 From the second pop-up menu, select **Local AppleTalk zone**.
- 9 Select the printer from the list.
- 10 Click **Add**.

Note: If the printer doesn't show up in the list, you may need to add it using the IP address. Contact your system support person for assistance.

Changing port settings after installing a new network Internal Solutions Port

When a new network Lexmark Internal Solutions Port (ISP) is installed in the printer, the printer configurations on computers that access the printer must be updated because the printer will be assigned a new IP address. All computers that access the printer must be updated with this new IP address in order to print to it over the network.

Notes:

- If the printer has a static IP address that will stay the same, then you do not need to make any changes to the computer configurations.
- If the computers are configured to print to the printer by a network name that will stay the same, instead of by IP address, then you do not need to make any changes to the computer configurations.
- If you are adding a wireless ISP to a printer previously configured for a wired connection, then make sure the wired network is disconnected when you configure the printer to operate wirelessly. If the wired connection remains connected, then the wireless configuration will complete, but the wireless ISP will not be active. In the event that the printer was configured for a wireless ISP while still attached to a wired connection, disconnect the wired connection, turn the printer off, and then turn the printer back on again. This will enable the wireless ISP.
- Only one network connection at a time is active. If you want to switch the connection type between wired and wireless, you must first turn the printer off, connect the cable (to switch to a wired connection) or disconnect the cable (to switch to a wireless connection), and then turn the printer back on again.

For Windows users

- 1 Print a network setup page and make a note of the new IP address.
- 2 Click , or click **Start** and then click **Run**.
- 3 In the Start Search or Run box, type **control printers**.
- 4 Press **Enter**, or click **OK**.
The printer folder opens.
- 5 Locate the printer that has changed.
Note: If there is more than one copy of the printer, then update all of them with the new IP address.
- 6 Right-click the printer.
- 7 Click **Properties**.
- 8 Click the **Ports** tab.
- 9 Locate the port in the list, and then select it.
- 10 Click **Configure Port**.
- 11 Type the new IP address in the “Printer Name or IP Address” field. You can find the new IP address on the network setup page you printed in step 1.
- 12 Click **OK**, and then click **Close**.

For Macintosh users

- 1 Print a network setup page and make a note of the new IP address.
- 2 Locate the printer IP address in the TCP/IP section of the network setup page. You will need the IP address if you are configuring access for computers on a different subnet than the printer.
- 3 Add the printer:
 - For IP printing:

In Mac OS X version 10.5 or later

- a From the Apple menu, choose **System Preferences**.
- b Click **Print & Fax**.
- c Click **+**.
- d Click **IP**.
- e Type in the IP address of your printer in the Address field.
- f Click **Add**.

In Mac OS X version 10.4 and earlier

- a From the Go menu, choose **Applications**.
 - b Double-click **Utilities**.
 - c Double-click **Printer Setup Utility** or **Print Center**.
 - d From the Printer List, click **Add**.
 - e Click **IP**.
 - f Type in the IP address of your printer in the Address field.
 - g Click **Add**.
- For AppleTalk printing:

In Mac OS X version 10.5

- a From the Apple menu, choose **System Preferences**.
- b Click **Print & Fax**.
- c Click **+**.
- d Click **AppleTalk**.
- e Select the printer from the list.
- f Click **Add**.

In Mac OS X version 10.4 and earlier

- a From the Go menu, choose **Applications**.
- b Double-click **Utilities**.
- c Double-click **Print Center** or **Printer Setup Utility**.
- d From the Printer List, click **Add**.
- e Choose the **Default Browser** tab.
- f Click **More Printers**.
- g From the first pop-up menu, choose **AppleTalk**.
- h From the second pop-up menu, select **Local AppleTalk zone**.
- i Select the printer from the list.
- j Click **Add**.

Setting up serial printing

In serial printing, data is transferred one bit at a time. Although serial printing is usually slower than parallel printing, it is the preferred option when there is a great deal of distance between the printer and computer or when an interface with a better transfer rate is not available.

After installing the serial port, you will need to configure the printer and the computer so they can communicate. Make sure you have connected the serial cable to the serial port on your printer.

1 Set the parameters in the printer:

- a From the printer control panel, navigate to the menu with port settings.
- b Locate the submenu with serial port settings.
- c Make any necessary changes to the serial settings.
- d Save the new settings.
- e Print a menu settings page.

2 Install the printer driver:

- a Insert the *Software and Documentation* CD. It launches automatically.
If the CD does not launch automatically, then do the following:
 - 1 Click , or click **Start** and then click **Run**.
 - 2 In the Start Search or Run box, type **D:\setup.exe**, where **D** is the letter of your CD or DVD drive.
- b Click **Install Printer and Software**.
- c Click **Agree** to accept the Printer Software License Agreement.
- d Click **Custom**.
- e Make sure **Select Components** is selected, and then click **Next**.
- f Make sure **Local** is selected, and then click **Next**.
- g Select the manufacturer of the printer from the menu.
- h Select the printer model from the menu, and then click **Add Printer**.
- i Click the **+** beside the printer model under **Select Components**.
- j Make sure the correct port is available under **Select Components**. This is the port where the serial cable attaches to the computer. If the correct port is not available, select the port under the **Select Port** menu, and then click **Add Port**.
- k Make any configuration changes necessary in the **Add a New Port** window. Click **Add Port** to finish adding the port.
- l Make sure the box next to the selected printer model is checked.
- m Select any other optional software you want to install, and then click **Next**.
- n Click **Finish** to complete the printer software installation.

3 Set the COM port parameters:

After the printer driver is installed, you must set the serial parameters in the communications (COM) port assigned to the printer driver.

The serial parameters in the COM port must match the serial parameters you set in the printer.

- a** Open the Device Manager.
 - 1** Click , or click **Start** and then click **Run**.
 - 2** In the Start Search or Run box, type `devmgmt.msc`.
 - 3** Press **Enter**, or click **OK**.
The Device Manager opens.
- b** Click **+** to expand the list of available ports.
- c** Select the communications port where you attached the serial cable to your computer (example: COM1).
- d** Click **Properties**.
- e** On the Port Settings tab, set the serial parameters to the same serial parameters in the printer.
Look for the printer settings under the serial heading on the Menu Settings page you printed earlier.
- f** Click **OK**, and then close all the windows.
- g** Print a test page to verify printer installation. When a test page prints successfully, printer setup is complete.

Minimizing your printer's environmental impact

Lexmark is committed to environmental sustainability and is continually improving its printers to reduce their impact on the environment. We design with the environment in mind, engineer our packaging to reduce materials, and provide collection and recycling programs. For more information, see:

- The Notices chapter
- The Environmental Sustainability section of the Lexmark Web site at www.lexmark.com/environment
- The Lexmark recycling program at www.lexmark.com/recycling

By selecting certain printer settings or tasks, you may be able to reduce your printer's impact even further. This chapter outlines the settings and tasks that may yield a greater environmental benefit.

Saving paper and toner

Using recycled paper

As an environmentally conscious company, Lexmark supports the use of recycled office paper produced specifically for use in laser printers. For more information on recycled papers that work well with your printer, see "Using recycled paper and other office papers" on page 88.

Conserving supplies

There are a number of ways you can reduce the amount of paper and toner you use when printing, copying, or receiving faxes. You can:

Use both sides of the paper

You can control whether print appears on one or two sides of the paper for a printed document, a copy, or an incoming fax. For more information, see:

- "Printing on both sides of the paper (duplexing)" on page 93
- "Copying on both sides of the paper (duplexing)" on page 105
- "Printing an incoming fax on both sides of the paper (duplexing)" on page 140

Place multiple pages on one sheet of paper

You can print up to 16 consecutive pages of a multiple-page document onto one side of a single sheet of paper from the Print dialog.

To copy two or four consecutive pages of a multiple-page document onto one side of a single sheet of paper, see "Copying multiple pages onto a single sheet" on page 107.

Choose scanning

You can avoid making a paper output of a document or photograph by scanning it and then saving it to a computer program, application, or flash drive. For more information, see:

- "Sending an e-mail using the touch screen" on page 116
- "Scanning to a computer" on page 150

- “Scanning to a flash drive” on page 153

Check your first draft for accuracy

Before printing or making multiple copies of a document:

- Use the Lexmark preview feature, which you can select from the Print dialog, the Lexmark Toolbar, or the printer display, to see what the document will look like before you print it.
- Print one copy of the document to check its content and format for accuracy.

Avoid paper jams

Carefully select and load paper to avoid paper jams. For more information, see “Avoiding jams” on page 75.

Saving energy

Using Eco-Mode

Use Eco-Mode to quickly select one or more ways to reduce your printer's environmental impact.

Note: See the table for the multiple settings that change when you select an Eco-Mode setting.

Choose	To
Energy	Reduce energy use, especially when the printer is idle. <ul style="list-style-type: none"> • Printer engine motors do not start until a job is ready to print. You may notice a short delay before the first page is printed. • The printer enters Power Saver mode after one minute of inactivity. • When the printer enters Power Saver mode, the printer control panel display and the standard exit bin lights are turned off. • The scanner lamps are activated only when a scan job is started.
Paper	<ul style="list-style-type: none"> • Enable the automatic duplex feature • Turn off print log features.
Energy/Paper	Use all the settings associated with Energy mode and Paper mode.
Off	Use factory default settings for all settings associated with Eco-Mode. This setting supports the performance specifications for your printer.

To select an Eco-Mode setting:

- 1 On the home screen, touch .
- 2 Touch **Settings**.
- 3 Touch **General Settings**.
- 4 Touch **Eco-Mode**.
- 5 Touch the arrows to select a setting.
- 6 Touch **Submit**.
Submitting changes appears.

Adjusting Power Saver

To save energy, you can decrease the number of minutes before the printer enters Power Saver mode.

Available settings range from 1–240 minutes. The factory default setting is 30 minutes.



Using the Embedded Web Server

- 1 Type the printer IP address into the address field of your Web browser.

Note: If you do not know the IP address of the printer, then print a network setup page and locate the IP address in the TCP/IP section.

- 2 Click **Settings**, and then click **General Settings**.
- 3 Click **Timeouts**.
- 4 In the Power Saver box, type in the number of minutes you want the printer to wait before it enters Power Saver mode.
- 5 Click **Submit**.

Using the printer control panel

- 1 Make sure the printer is on and **Ready** appears.
- 2 On the home screen, touch .
- 3 Touch **Settings**.
- 4 Touch **General Settings**.
- 5 Touch the down arrow until **Timeouts** appears.
- 6 Touch **Timeouts**.
- 7 Touch the arrows next to **Power Saver Mode** to select the number of minutes you want the printer to wait before it enters Power Saver mode.
- 8 Touch **Submit**.
- 9 Touch .

Adjusting the brightness of the display

To save energy, or if you are having trouble reading your display, you can adjust the brightness of the display.

Available settings range from 20–100 . The factory default setting is 100.



Using the Embedded Web Server

- 1 Type the printer IP address into the address field of your Web browser.

Note: If you do not know the IP address of the printer, then print a network setup page and locate the IP address in the TCP/IP section.

- 2 Click **Settings**, and then click **General Settings**.
- 3 In the Screen Brightness box, type in the brightness percentage you want for your home screen.
- 4 Click **Submit**.

Using the printer control panel

- 1 Make sure the printer is on and **Ready** appears.
- 2 On the home screen, touch .
- 3 Touch **Settings**.
- 4 Touch **General Settings**.
- 5 Touch the down arrow until **Screen Brightness** appears.
- 6 Touch the arrows to select a setting.
- 7 Touch **Submit**.
- 8 Touch .

Setting the standard exit bin light

To save energy, you can dim or turn off the output lighting for the standard exit bin.

Available settings are Off, Dim, and Bright.

The factory default setting for Normal/Standby Mode is Bright.

The factory default setting for Power Saver is Dim.

Using the Embedded Web Server

- 1 Type the printer IP address into the address field of your Web browser.
Note: If you do not know the IP address of the printer, then print a network setup page and locate the IP address in the TCP/IP section.
- 2 Click **Settings**, and then click **General Settings**.
- 3 Click **Output Lighting**.
- 4 From the Normal/Standby Mode list, select the light setting the standard exit bin will use when in Ready or Standby mode.
- 5 From the Power Saver list, select the light setting the standard exit bin will use when in Power Saver mode.
Note: For more information on Power Saver mode, see “Adjusting Power Saver” on page 70.
- 6 Click **Submit**.

Using the printer control panel

- 1 Make sure the printer is on and **Ready** appears.
- 2 On the home screen, touch .
- 3 Touch **Settings**, and then touch **General Settings**.
- 4 Touch the down arrow until **Output Lighting** appears.
- 5 Touch **Output Lighting**.
- 6 Touch the arrow button next to **Normal/Standby Mode** to select the light settings the standard exit bin will use when in Ready or Standby mode.

- 7 Touch the arrow button next to **Power Saver** to select the light setting the standard exit bin will use when in Power Saver mode.

Note: For more information on Power Saver mode, see “Adjusting Power Saver” on page 70.

- 8 Touch **Submit**.

- 9 Touch .

Recycling

Lexmark provides collection programs and environmentally progressive approaches to recycling. For more information, see:

- The Notices chapter
- The Environmental Sustainability section of the Lexmark Web site at www.lexmark.com/environment
- The Lexmark recycling program at www.lexmark.com/recycling

Recycling Lexmark products

To return Lexmark products to Lexmark for recycling:

- 1 Visit our Web site at www.lexmark.com/recycle.
- 2 Find the product type you want to recycle, and then select your country from the list.
- 3 Follow the instructions on the computer screen.

Recycling Lexmark packaging

Lexmark continually strives to minimize packaging. Less packaging helps to ensure that Lexmark printers are transported in the most efficient and environmentally sensitive manner and that there is less packaging to dispose of. These efficiencies result in fewer greenhouse emissions, energy savings, and natural resource savings.

Lexmark cartons are 100% recyclable where corrugated recycling facilities exist. Facilities may not exist in your area.

Expanded polystyrene (EPS) foam used in Lexmark packaging is recyclable where foam recycling facilities exist. Facilities may not exist in your area. For information on EPS foam recycling locations:

- 1 Visit EPS Recycling International's Web site at www.epsrecycling.org/pages/intcon.html.
- 2 Select your country or region from the list, and then click the links or use the contact information provided.

When you return a cartridge to Lexmark, you can reuse the box that the cartridge came in. Lexmark will recycle the box.

Returning Lexmark cartridges for reuse or recycling

The Lexmark Cartridge Collection Program diverts millions of Lexmark cartridges from landfills annually by making it both easy and free for Lexmark customers to return used cartridges to Lexmark for reuse or recycling. One hundred percent of the empty cartridges returned to Lexmark are either reused or demanufactured for recycling. Boxes used to return the cartridges are also recycled.

To return Lexmark cartridges for reuse or recycling, follow the instructions that came with your printer or cartridge and use the pre-paid shipping label. You can also:

- 1 Visit our Web site at www.lexmark.com/recycle.
- 2 From the Toner Cartridges section, select your country from the list.
- 3 Follow the instructions on the computer screen.

Reducing printer noise

Use Quiet Mode to reduce the printer noise.

Note: See the table for the multiple settings that change when you select a Quiet Mode setting.

Choose	To
On	Reduce printer noise. <ul style="list-style-type: none"> • You may notice a reduction in processing speed. • Printer engine motors do not start until a job is ready to print. You may notice a short delay before the first page is printed. • Fans run at a reduced speed or are turned off. • If your printer has faxing capability, fax sounds are reduced or disabled, including those made by the fax speaker and ringer.
Off	Use factory default settings. This setting supports the performance specifications for your printer.

To select a Quiet Mode setting:



- 1 On the home screen, touch .
- 2 Touch **Settings**.
- 3 Touch **General Settings**.
- 4 Touch **Quiet Mode**.
- 5 Touch the arrows to select a setting.
- 6 Touch **Submit**.
Submitting changes appears.

Loading paper and specialty media

This section explains how to load the trays and feeders. It also includes information about paper orientation, setting the Paper Size and Paper Type, and linking and unlinking trays.

Setting the Paper Size and Paper Type

The Paper Size setting for the standard 250 tray and the multipurpose feeder must be set manually from the Paper size menu. The factory default Paper Type setting is Plain Paper. The Paper Type setting must be set manually for all trays that do not contain plain paper.

- 1 Make sure the printer is on and **Ready** appears.
- 2 On the home screen, touch .
- 3 Touch **Paper Menu**.
- 4 Touch **Paper Size/Type**.
- 5 Touch the arrows for the desired tray until the correct size or type setting appears.
- 6 Touch **Submit**.
- 7 Touch  to return to the home screen.

Configuring Universal paper settings

The Universal Paper Size is a user-defined setting that lets you print on paper sizes that are not preset in the printer menus. Set the Paper Size for the specified tray to Universal when the size you want is not available from the Paper Size menu. Then, specify all of the following Universal size settings for your paper:

- Units of measure (millimeters or inches)
- Portrait Width
- Portrait Height

Note: The smallest supported Universal size is 76 x 76 mm (3 x 3 in.); the largest size is 216 x 356 mm (8.5 x 14 in.).

Specify the Universal Paper Size measurement

- 1 Make sure the printer is on and **Ready** appears.
- 2 On the home screen, touch .
- 3 Touch **Paper Menu**.
- 4 Touch the down arrow until **Universal Setup** appears, and then touch **Universal Setup**.
- 5 Touch the left or right arrow to select the desired unit of measure.
- 6 Touch **Portrait Width** or **Portrait Height**.
- 7 Touch the arrows to select the desired width or height.

8 Touch **Submit** to save your selection.

Submitting Selection appears, followed by the Paper menu.

9 Touch  to return to the home screen.

Avoiding jams

The following hints can help you avoid jams:

Paper tray recommendations

- Make sure the paper lies flat in the paper tray.
- Do not remove the paper tray while the printer is printing.
- Do not load the paper tray while the printer is printing. Load it prior to printing, or wait for a prompt to load it.
- Do not load too much paper. Make sure the stack height does not exceed the indicated maximum height.
- Make sure the guides in the paper tray or the manual feeder are properly positioned and are not pressing too tightly against the paper or envelopes.
- Push the paper tray in firmly after loading paper.

Paper recommendations

- Use only recommended paper or specialty media.
- Do not load wrinkled, creased, damp, bent, or curled paper.
- Flex, fan, and straighten paper before loading it.

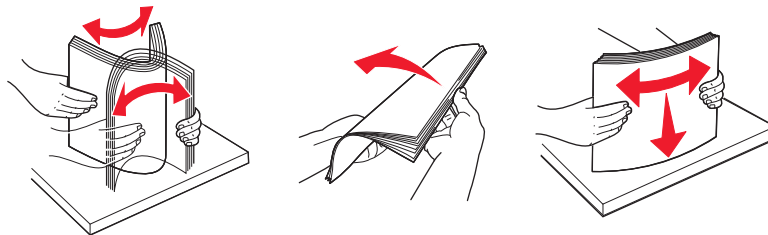

- Do not use paper that has been cut or trimmed by hand.
- Do not mix paper sizes, weights, or types in the same stack.
- Make sure all sizes and types are set correctly in the printer control panel menus.
- Store paper per the manufacturer's recommendations.

Loading trays

1 Pull the tray completely out.

Note: Do not remove trays while a job prints or while **Busy** appears on the display. Doing so may cause a jam.

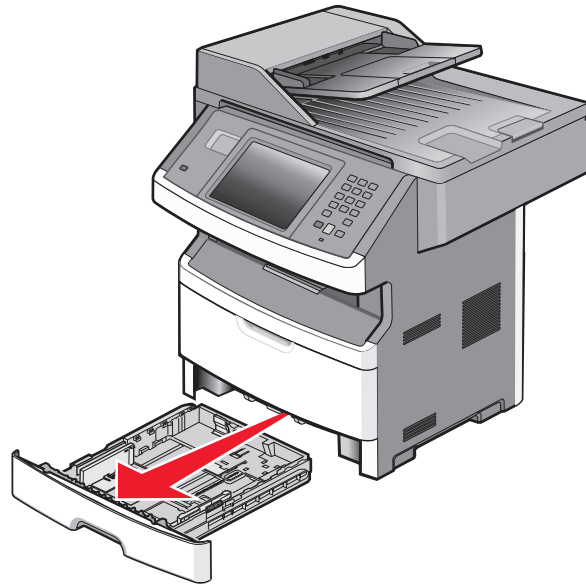

2 Squeeze and slide the guides to the correct position for the paper size you are loading.

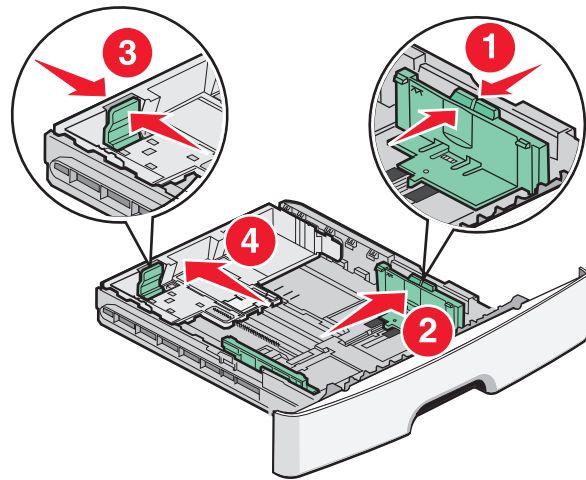

For long paper like A4 or legal, squeeze and slide the length guide backwards to accommodate the length of paper you are loading.

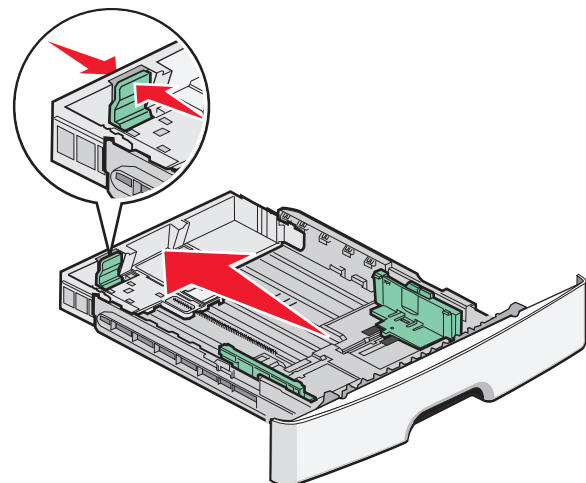

If you are loading A6-size paper:

- a** Squeeze and slide the length guide toward the center of the tray to the A5 size position.
- b** Raise the A6 backstop.

Notes:

- The standard tray accommodates only 150 sheets of A6-size paper. Notice the maximum fill line on the A6 backstop which indicates the maximum height for loading A6-size paper. Do not try to overload the tray.
- A6-size paper cannot be loaded in the optional tray.

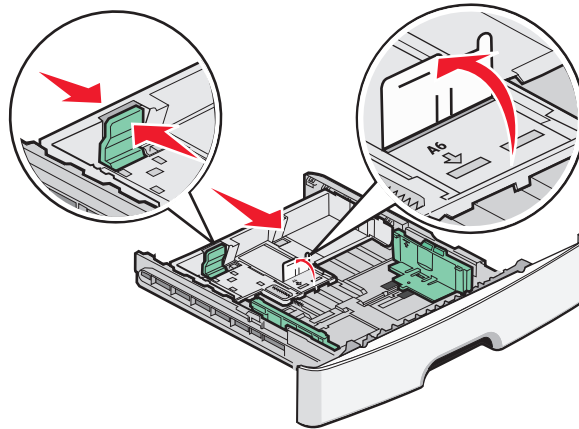

Note: Use the size indicators on the bottom of the tray to help position the guide.

- 3** Flex a stack of paper back and forth to loosen the sheets, and then fan them. Do not fold or crease the paper. Straighten the edges on a level surface.

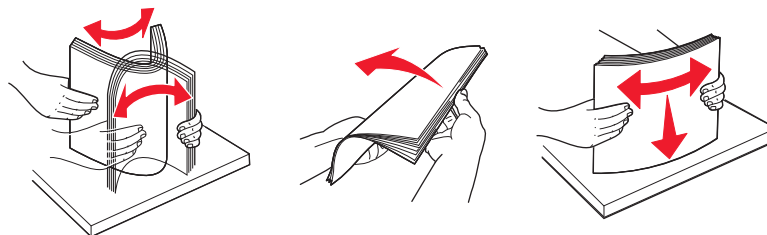

- 4** Load the paper stack toward the back of the tray as shown with the recommended print side facedown.

Note: The maximum fill line on the width guide indicates the maximum height for loading paper. Do not load A6-size paper to the maximum fill line; the tray holds only 150 sheets of A6-size paper.

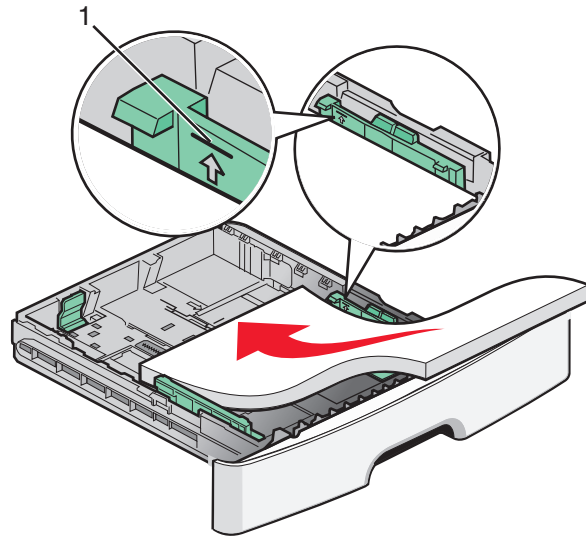

1 Maximum fill line

Load letterhead with the top edge of the sheet toward the front of the tray and the design facedown.

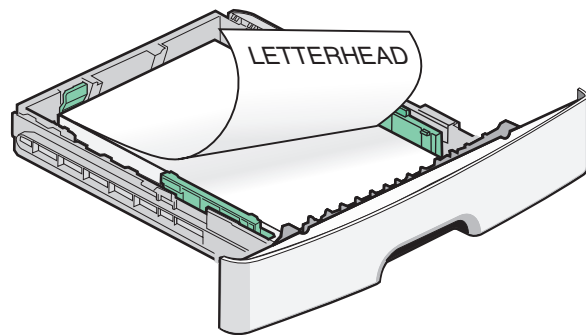

5 Squeeze and slide the guides to lightly touch the side of the stack.

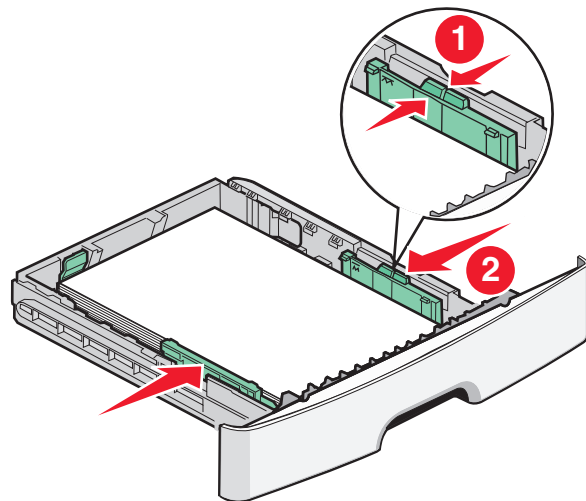

- 6 Insert the tray.

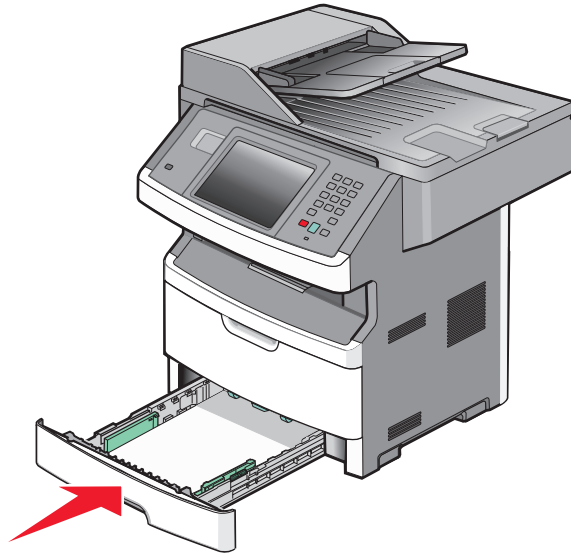

- 7 If the paper type you loaded differs from the type that was previously loaded in the tray, then change the Paper Size/Type setting on the Paper menu.

Using the multipurpose feeder

You may want to use the multipurpose feeder when you print on different sizes and types of papers or specialty media, such as card stock, transparencies, paper labels, and envelopes. You may also want to use the multipurpose feeder for single-page print jobs on letterhead or on other specialty media you do not keep in a tray.

Opening the multipurpose feeder

- 1 Grasp the handle, and pull the multipurpose feeder door down.



2 Grasp the raised handle, and pull the extension forward.

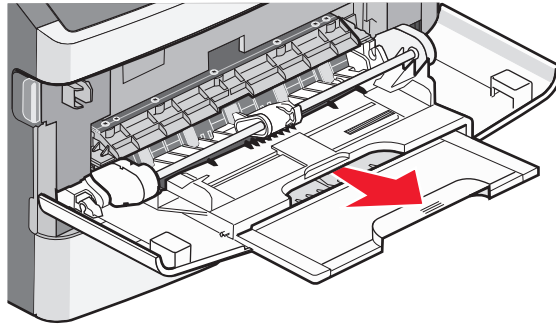

3 Grasp the handle, and pull the extension so it flips forward.

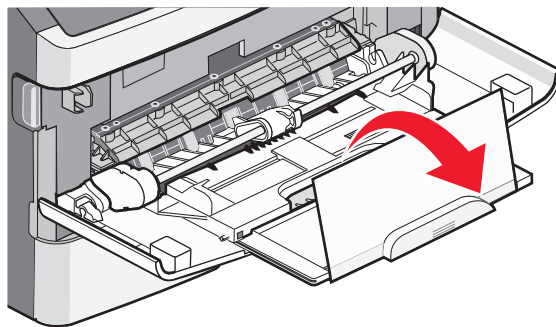

4 Guide the extension down gently so the multipurpose feeder is extended fully and open.

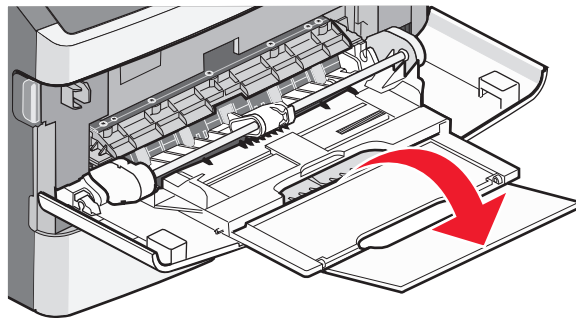

Loading the multipurpose feeder

- 1 Squeeze the tab located on the right width guide, and move the guides out fully.

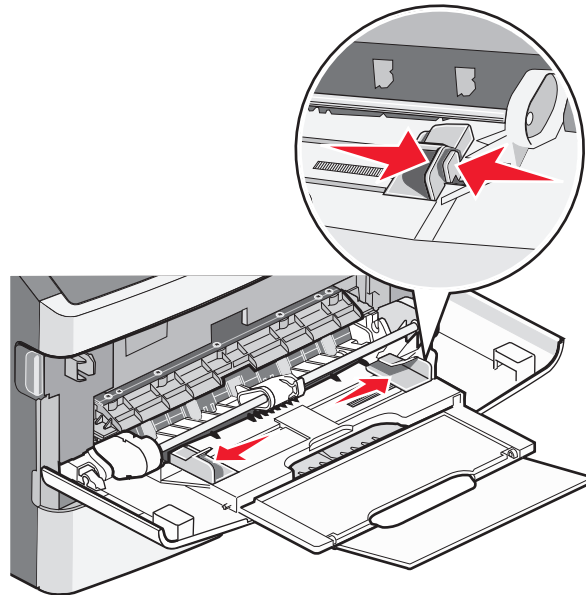

- 2 Prepare the paper or specialty media for loading.

- Flex sheets of paper or paper labels back and forth to loosen them, and then fan them. Do not fold or crease the paper or labels. Straighten the edges on a level surface.

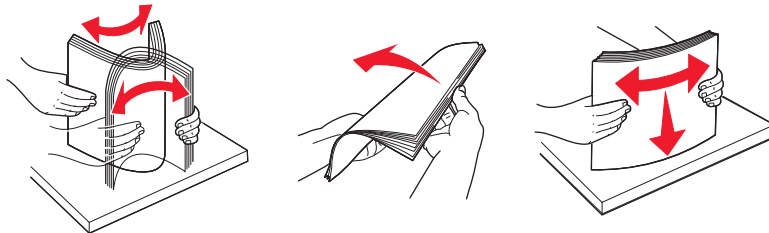

- Hold transparencies by the edges, and then fan them. Straighten the edges on a level surface.

Note: Avoid touching the print side of the transparencies. Be careful not to scratch them.

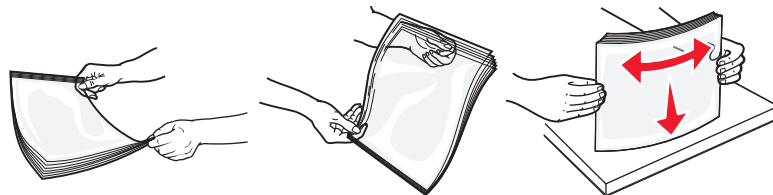

- Flex a stack of envelopes back and forth to loosen them, and then fan them. Straighten the edges on a level surface.

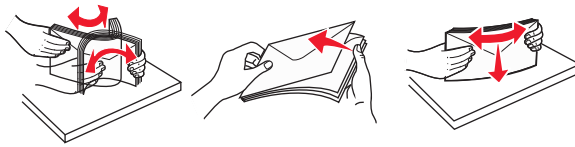

Note: Fanning prevents the edges of envelopes from sticking together. It also helps them feed properly to avoid jams. Do not fold or crease envelopes.

3 Load the paper or specialty media.

Notes:

- Do not force any paper into the multipurpose feeder. Overfilling may cause jams.
- Do not exceed the maximum stack height by forcing paper or specialty media under the stack height limiters which are located on the guides.

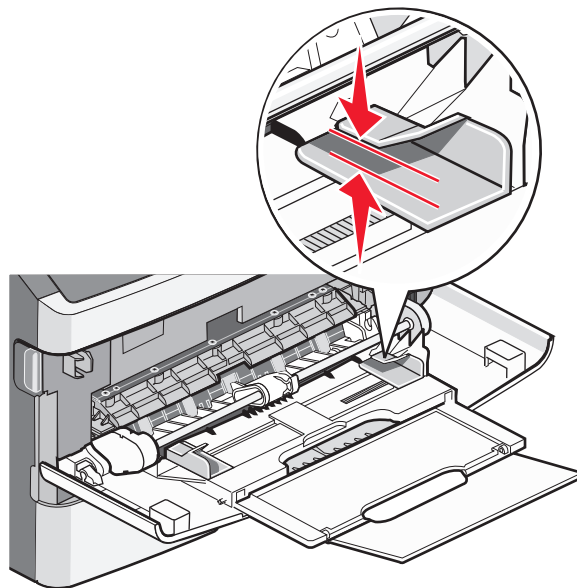

- Load paper, transparencies, and card stock with the recommended print side faceup and the top edge entering the printer first. For more information on loading transparencies, see the packaging the transparencies came in.

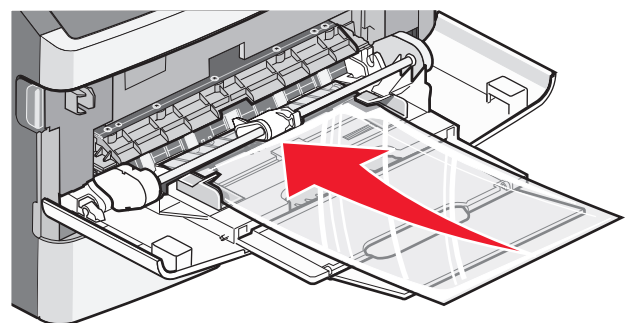
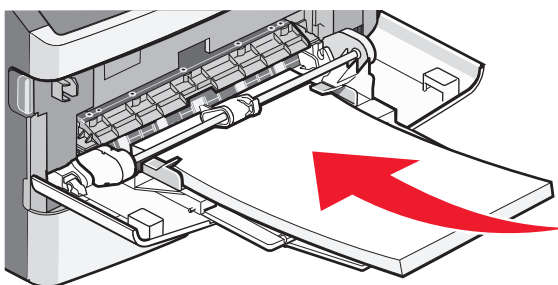

- Load letterhead with the logo faceup and the top edge entering the printer first.

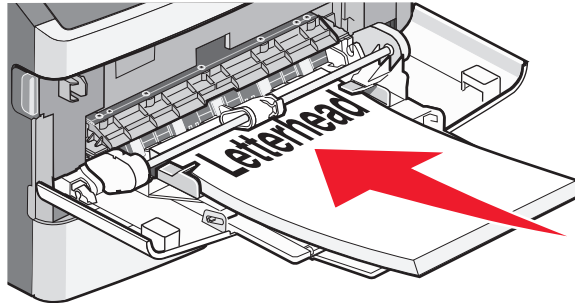

- Load envelopes with the flap side down and the stamp location in the position shown. The stamp and address are shown to illustrate the proper orientation for loading envelopes.

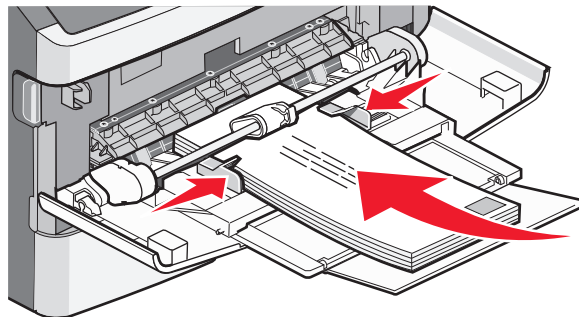

Warning—Potential Damage: Never use envelopes with stamps, clasps, snaps, windows, coated linings, or self-stick adhesives. These envelopes may severely damage the printer.

- 4 Squeeze the tab located on the right width guide to adjust the guides to lightly touch the sides of the stack.

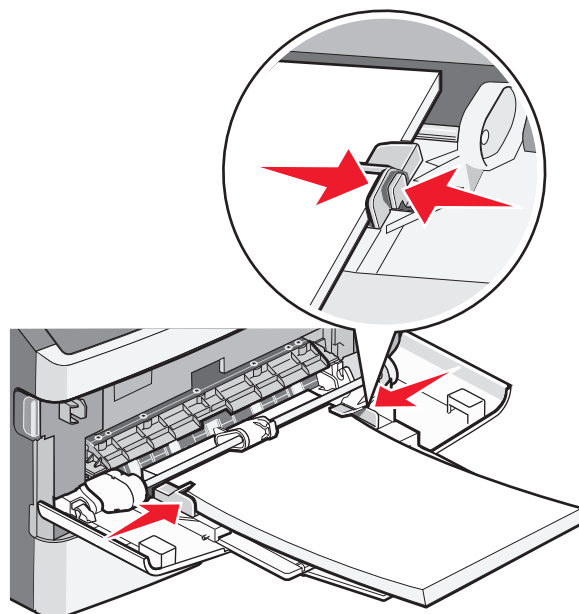

- 5 Slide the paper gently into the multipurpose feeder until it comes to a stop. Paper should lie flat in the multipurpose feeder. Make sure the paper fits loosely in the multipurpose feeder and is not bent or wrinkled.

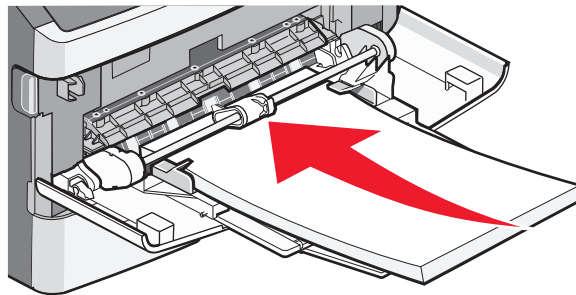

- 6 From the printer control panel, set the Paper Size and Paper Type.

Linking and unlinking trays

Linking trays

Tray linking is useful for large print jobs or multiple copies. When one linked tray is empty, paper feeds from the next linked tray. The Size and Type settings for all trays must be set from the Paper menu.

To set the paper type or size:

- 1 On the home screen, touch .
- 2 Touch **Paper Menu**.
- 3 Touch **Paper Size/Type**.

Note: To link the multipurpose feeder, Configure MP must be set to Cassette in order for MP Feeder Size or MP Feeder Type to appear as a menu item.

- 4 Touch the right or left arrows to select the same size paper from all paper sources to be linked.
- 5 Touch the right or left arrows to select the same type paper from all paper sources to be linked.

Note: When the Size and Type settings are the same for any trays, the trays are automatically linked.

- 6 Touch **Submit**.
Submitting changes appears.
- 7 Touch  to return to the home screen.

Unlinking trays

Unlinked trays have settings that are *not* the same as the settings of any other tray.

To unlink a tray, change the following tray settings so that they do not match the settings of any other tray:

- **Paper Type** (for example: Plain Paper, Letterhead, Custom Type <x>)
Paper Type names describe the paper characteristics. If the name that best describes your paper is used by linked trays, assign a different Paper Type name to the tray, such as Custom Type <x>, or define your own custom name.
- **Paper Size** (for example: letter, A4, statement)
Paper Size settings are not automatic; they must be set manually from the Paper Size/Type menu.

Warning—Potential Damage: Do not assign a Paper Type name that does not accurately describe the type of paper loaded in the tray. The temperature of the fuser varies according to the specified Paper Type. Paper may not be properly processed if an inaccurate Paper Type is selected.

Assigning a custom paper type name

Assign a custom paper type name to a tray when linking or unlinking the tray.

- 1 Make sure the printer is on and **Ready** appears.
- 2 From the home screen, touch .
- 3 Touch **Paper Menu**.
- 4 Touch **Paper Size/Type**.
- 5 Touch the paper type arrows for the desired tray until the correct custom type appears.
- 6 Touch the tray number or **MP Feeder Type**.
- 7 Touch **Submit**.

Changing a Custom Type <x> name

You can use the Embedded Web Server or MarkVision Professional™ to define a name other than Custom Type <x> for each of the custom paper types that are loaded. When a Custom Type <x> name is changed, the menus display the new name instead of Custom Type <x>.

To change a Custom Type <x> name from the Embedded Web Server:

- 1 Type the printer IP address into the address field of your Web browser.
Note: If you do not know the IP address of the printer, then print a network setup page and locate the IP address in the TCP/IP section.
- 2 Click **Settings**.
- 3 Under Default Settings, click **Paper Menu**.
- 4 Click **Custom Names**.
- 5 Type a name for the paper type in a Custom Name <x> box.
Note: This custom name will replace a custom type <x> name under the Custom Types and Paper Size/Type menus.
- 6 Click **Submit**.
- 7 Click **Custom Types**.
Custom Types appears, followed by your custom name.

8 Select a Paper Type setting from the list next to your custom name.

9 Click **Submit**.

Paper and specialty media guidelines

Paper guidelines

Selecting the correct paper or specialty media reduces printing problems. For the best print quality, try a sample of the paper or specialty media before buying large quantities.

Paper characteristics

The following paper characteristics affect print quality and reliability. Consider these characteristics when evaluating new paper stock.

Note: For detailed information on card stock and labels, see the *Card Stock & Label Guide* available on the Lexmark Web site at www.lexmark.com/publications.

Weight

The printer can automatically feed paper weights from 60–176 g/m² (16–47 lb bond) grain long. Paper lighter than 60 g/m² (16 lb) might not be stiff enough to feed properly, causing jams. For best performance, use 75 g/m² (20 lb bond) grain long paper. For paper smaller than 182 x 257 mm (7.2 x 10.1 in.), we recommend 90 g/m² (24 lb) or heavier paper.

Curl

Curl is the tendency for paper to curl at its edges. Excessive curl can cause paper feeding problems. Curl can occur after the paper passes through the printer, where it is exposed to high temperatures. Storing paper unwrapped in hot, humid, cold, or dry conditions, even in the trays, can contribute to paper curling prior to printing and can cause feeding problems.

Smoothness

Paper smoothness directly affects print quality. If paper is too rough, then toner cannot fuse to it properly. If paper is too smooth, then it can cause paper feeding or print quality issues. Always use paper between 100 and 300 Sheffield points; smoothness between 150 and 250 Sheffield points produces the best print quality.

Moisture content

The amount of moisture in paper affects both print quality and the ability of the printer to feed the paper correctly. Leave paper in its original wrapper until it is time to use it. This limits the exposure of paper to moisture changes that can degrade its performance.

Condition paper before printing by storing it in its original wrapper in the same environment as the printer for 24 to 48 hours before printing. Extend the time several days if the storage or transportation environment is very different from the printer environment. Thick paper may also require a longer conditioning period.

Grain direction

Grain refers to the alignment of the paper fibers in a sheet of paper. Grain is either *grain long*, running the length of the paper, or *grain short*, running the width of the paper.

For 60–176 g/m² (16–47 lb bond) paper, grain long paper is recommended. For paper heavier than 176 g/m², grain short is recommended.

Fiber content

Most high-quality xerographic paper is made from 100% chemically treated pulped wood. This content provides the paper with a high degree of stability resulting in fewer paper feeding problems and better print quality. Paper containing fibers such as cotton can negatively affect paper handling.

For detailed information on paper with recycled fiber content, see “Using recycled paper and other office papers” on page 88.

Unacceptable paper

The following paper types are not recommended for use with the printer:

- Chemically treated papers used to make copies without carbon paper, also known as carbonless papers, carbonless copy paper (CCP), or no carbon required (NCR) paper
- Preprinted papers with chemicals that may contaminate the printer
- Preprinted papers that can be affected by the temperature in the printer fuser
- Preprinted papers that require a registration (the precise print location on the page) greater than ±2.3 mm (±0.9 in.), such as optical character recognition (OCR) forms

In some cases, registration can be adjusted with a software application to successfully print on these forms.

- Coated papers (erasable bond), synthetic papers, thermal papers
- Rough-edged, rough or heavily textured surface papers, or curled papers
- Recycled papers that fail EN12281:2002 (European)
- Paper weighing less than 60 g/m² (16 lb)
- Multiple-part forms or documents

Selecting paper

Using appropriate paper prevents jams and helps ensure trouble-free printing.

To help avoid jams and poor print quality:

- *Always* use new, undamaged paper.
- Before loading paper, know the recommended print side of the paper. This information is usually indicated on the paper package.
- *Do not* use paper that has been cut or trimmed by hand.
- *Do not* mix paper sizes, types, or weights in the same source; mixing results in jams.
- *Do not* use coated papers unless they are specifically designed for electrophotographic printing.

Using recycled paper and other office papers

As an environmentally conscious company, Lexmark supports the use of recycled office paper produced specifically for use in laser (electrophotographic) printers. In 1998, Lexmark presented to the US government a study demonstrating that recycled paper produced by major mills in the US fed as well as non-recycled paper. However, no blanket statement can be made that *all* recycled paper will feed well.

Lexmark consistently tests its printers with recycled paper (20–100% post-consumer waste) and a variety of test paper from around the world, using chamber tests for different temperature and humidity conditions. Lexmark has found no reason to discourage the use of today's recycled office papers, but generally the following property guidelines apply to recycled paper.

- Low moisture content (4–5%)
- Suitable smoothness (100–200 Sheffield units, or 140–350 Bendtsen units, European)

Note: Some much smoother papers (such as premium 24 lb laser papers, 50–90 Sheffield units) and much rougher papers (such as premium cotton papers, 200–300 Sheffield units) have been engineered to work very well in laser printers, despite surface texture. Before using these types of paper, consult your paper supplier.

- Suitable sheet-to-sheet coefficient of friction (0.4–0.6)
- Sufficient bending resistance in the direction of feed

Recycled paper, paper of lower weight (<60 g/m² [16 lb bond]) and/or lower caliper (<3.8 mils [0.1 mm]), and paper that is cut grain-short for portrait (or short-edge) fed printers may have lower bending resistance than is required for reliable paper feeding. Before using these types of paper for laser (electrophotographic) printing, consult your paper supplier. Remember that these are general guidelines only and that paper meeting these guidelines may still cause paper feeding problems in any laser printer (for example, if the paper curls excessively under normal printing conditions).

Selecting preprinted forms and letterhead

Use these guidelines when selecting preprinted forms and letterhead:

- Use grain long for 60 to 90 g/m² weight paper.
- Use only forms and letterhead printed using an offset lithographic or engraved printing process.
- Avoid papers with rough or heavily textured surfaces.

Use papers printed with heat-resistant inks designed for use in xerographic copiers. The ink must be able to withstand temperatures up to 230°C (446°F) without melting or releasing hazardous emissions. Use inks that are not affected by the resin in toner. Inks that are oxidation-set or oil-based generally meet these requirements; latex inks might not. When in doubt, contact the paper supplier.

Preprinted papers such as letterhead must be able to withstand temperatures up to 230°C (446°F) without melting or releasing hazardous emissions.

Storing paper

Use these paper storage guidelines to help avoid jams and uneven print quality:

- For best results, store paper where the temperature is 21°C (70°F) and the relative humidity is 40%. Most label manufacturers recommend printing in a temperature range of 18 to 24°C (65 to 75°F) with relative humidity between 40 and 60%.
- Store paper in cartons when possible, on a pallet or shelf, rather than on the floor.
- Store individual packages on a flat surface.
- Do not store anything on top of individual paper packages.

Supported paper sizes, types, and weights

The following tables provide information on standard and optional paper sources and the types of paper they support.

Note: For an unlisted paper size, configure a Universal Paper Size.

For information on card stock and labels, see the *Card Stock & Label Guide* on the Lexmark Web site at www.lexmark.com/publications.

Paper sizes supported by the printer

Paper size	Dimensions	Standard 250-sheet tray	Optional 250- or 550-sheet tray	Multipurpose feeder	Duplex path
A4	210 x 297 mm (8.3 x 11.7 in.)	✓	✓	✓	✓
A5	148 x 210 mm (5.8 x 8.3 in.)	✓	✓	✓	X
A6¹	105 x 148 mm (4.1 x 5.8 in.)	✓	X	✓	X
JIS B5	182 x 257 mm (7.2 x 10.1 in.)	✓	✓	✓	X
Letter	216 x 279 mm (8.5 x 11 in.)	✓	✓	✓	✓
Legal	216 x 356 mm (8.5 x 14 in.)	✓	✓	✓	✓
Executive	184 x 267 mm (7.3 x 10.5 in.)	✓	✓	✓	X
Oficio (Mexico)	216 x 340 mm (8.5 x 13.4 in.)	✓	✓	✓	✓
Folio	216 x 330 mm (8.5 x 13 in.)	✓	✓	✓	✓
Statement	140 x 216 mm (5.5 x 8.5 in.)	✓	✓	✓	X
Universal²	76.2 x 127 mm (3 x 5 in.) up to 216 x 356 mm (8.5 x 14 in.)	✓	✓	✓	X ³
7 3/4 Envelope (Monarch)	98 x 191 mm (3.9 x 7.5 in.)	X	X	✓	X
9 Envelope	98 x 225 mm (3.9 x 8.9 in.)	X	X	✓	X

¹ A6 is supported only for grain long papers.

² If a paper size you want to use is not listed, configure a Universal paper size. For more information, see “Configuring Universal paper settings” on page 74.

³ Universal paper size has limited support in the duplex path for paper sizes 210 x 279 mm (8.3 x 11 in.) or larger.

Paper size	Dimensions	Standard 250-sheet tray	Optional 250- or 550-sheet tray	Multipurpose feeder	Duplex path
10 Envelope	105 x 241 mm (4.1 x 9.5 in.)	X	X	✓	X
DL Envelope	110 x 220 mm (4.3 x 8.7 in.)	X	X	✓	X
C5 Envelope	162 x 229 mm (6.4 x 9 in.)	X	X	✓	X
B5 Envelope	176 x 250 mm (6.9 x 9.8 in.)	X	X	✓	X
Other Envelope	229 x 356 mm (9 x 14 in.)	X	X	✓	X

¹ A6 is supported only for grain long papers.

² If a paper size you want to use is not listed, configure a Universal paper size. For more information, see “Configuring Universal paper settings” on page 74.

³ Universal paper size has limited support in the duplex path for paper sizes 210 x 279 mm (8.3 x 11 in.) or larger.

Paper types and weights supported by the printer

The printer engine and the duplex path support 60–90 g/m² (16–24 lb) paper weights. The multipurpose feeder supports 60–163 g/m² (16–43 lb) paper weights.

Paper type	Standard 250-sheet tray	Optional 250- or 550-sheet tray	Multipurpose feeder	Manual feeder	Duplex path
Paper <ul style="list-style-type: none"> • Plain • Light • Heavy • Rough/Cotton • Recycled • Custom 	✓	✓	✓	✓	✓
Bond	✓	✓	✓	✓	✓
Letterhead	✓	✓	✓	✓	✓
Preprinted	✓	✓	✓	✓	✓
Colored Paper	✓	✓	✓	✓	✓
Card stock	✓	✓	✓	✓	✓
Glossy paper	X	X	X	X	X

¹ Single-sided paper labels designed for laser printers are supported for occasional use. It is recommended to print no more than 20 pages of paper labels a month. Vinyl, pharmacy, and dual-sided labels are not supported.

² Use envelopes that lie flat when individually placed on a table facedown.

Paper type	Standard 250-sheet tray	Optional 250- or 550-sheet tray	Multipurpose feeder	Manual feeder	Duplex path
Paper labels ¹	✓	✓	✓	✓	X
Transparencies	✓	✓	✓	✓	✓
Envelopes (smooth) ²	X	X	✓	✓	X

¹ Single-sided paper labels designed for laser printers are supported for occasional use. It is recommended to print no more than 20 pages of paper labels a month. Vinyl, pharmacy, and dual-sided labels are not supported.

² Use envelopes that lie flat when individually placed on a table facedown.

Paper capacities

The capacities of the trays and the multipurpose feeder are based on 75 g/m² (20 lb) paper.

Load up to	Notes
Tray 1 250 sheets of paper 150 sheets of A6-size paper 50 paper labels 50 transparencies	Note: Vinyl, pharmacy, or dual-sided labels are not supported. Use paper labels only. Single-sided paper labels designed for laser printers are supported for occasional use. It is recommended to print no more than 20 pages of paper labels per month.
Tray 2 250 or 550 sheets of paper 50 paper labels	Note: Only one optional drawer may be installed on the printer at a time. The maximum amount of paper that can be loaded depends on whether you have an optional 250- or 550-sheet tray.
Multipurpose feeder 50 sheets of paper 15 paper labels 10 transparencies 10 sheets of card stock 7 envelopes	Note: Feed paper into the multipurpose feeder only to the point where its leading edge can contact the paper guides. Do not force the paper into the feeder.

Printing

Printing a document

- 1 Load paper into a tray or feeder.
- 2 From the printer control panel Paper menu, set the Paper Type and Paper Size to match the loaded paper.
- 3 Do one of the following:

For Windows users

- a With a document open, click **File > Print**.
- b Click **Properties, Preferences, Options, or Setup**, and then adjust the settings as needed.

Note: To print on a specific size or type of paper, adjust the paper size or type settings to match the loaded paper, or select the appropriate tray or feeder.

- c Click **OK**, and then click **Print**.

For Macintosh users

- a Customize the settings as needed in the Page Setup dialog:
 - 1 With a document open, choose **File > Page Setup**.
 - 2 Choose a paper size or create a custom size to match the loaded paper.
 - 3 Click **OK**.

- b Customize the settings as needed in the Print dialog:
 - 1 With a document open, choose **File > Print**.
If necessary, click the disclosure triangle to see more options.
 - 2 From the Print dialog and pop-up menus, adjust the settings as needed.

Note: To print on a specific paper type, adjust the paper type setting to match the loaded paper, or select the appropriate tray or feeder.

- 3 Click **Print**.

Printing on both sides of the paper (duplexing)

In order to save paper, you can print a multiple-page document on both sides of the paper.

- 1 On the home screen, touch **Menus**, and then touch **Settings**.
- 2 Touch the down arrows until **Print Settings** appears.
- 3 Touch **Print Settings**.
- 4 Touch **Finishing Menu**.
- 5 Touch the **Sides (Duplex)** arrows until **2 sided** appears.

6 Touch Submit.

Submitting changes appears.

7 Touch  to return to the home screen.

Printing on specialty media

Tips on using letterhead

- Use letterhead designed specifically for laser printers.
- Print samples on the letterhead being considered for use before buying large quantities.
- Before loading letterhead, fan the stack to prevent sheets from sticking together.
- Page orientation is important when printing on letterhead. For information on how to load letterhead, see:
 - “Loading trays” on page 75
 - “Using the multipurpose feeder” on page 79

Tips on using transparencies

Print samples on the transparencies being considered for use before buying large quantities.

When printing on transparencies:

- Feed transparencies from a 250-sheet tray, a 550-sheet tray, or the multipurpose feeder.
- Use transparencies designed specifically for laser printers. Check with the manufacturer or vendor to ensure transparencies are able to withstand temperatures up to 230°C (446°F) without melting, discoloring, offsetting, or releasing hazardous emissions.
- Use transparencies that are 138–146 g/m² (37–39 lb. bond) in weight.
- To prevent print quality problems, avoid getting fingerprints on the transparencies.
- Before loading transparencies, fan the stack to prevent sheets from sticking together.
- We recommend Lexmark part number 12A5010 for A4-size transparencies and Lexmark part number 70X7240 for letter-size transparencies.

Tips on using envelopes

Print samples on the envelopes being considered for use before buying large quantities.

When printing on envelopes:

- Use envelopes designed specifically for laser printers. Check with the manufacturer or vendor to ensure the envelopes can withstand temperatures up to 210°C (410°F) without sealing, wrinkling, curling excessively, or releasing hazardous emissions.

Note: Envelopes can be printed at a temperature up to 220°C (428°F) if Envelope Weight is set to Heavy and Envelope Texture is set to Rough. Select these settings using the Embedded Web Server, or from the printer control panel Paper menu.

- For the best performance, use envelopes made from 90 g/m² (24 lb bond) paper. Use up to 105 g/m² (28 lb bond) weight for envelopes as long as the cotton content is 25% or less. All-cotton envelopes must not exceed 90 g/m² (24 lb bond) weight.

- Use only new envelopes.
- To optimize performance and minimize jams, do not use envelopes that:
 - Have excessive curl or twist
 - Are stuck together or damaged in any way
 - Have windows, holes, perforations, cutouts, or embossing
 - Have metal clasps, string ties, or folding bars
 - Have an interlocking design
 - Have postage stamps attached
 - Have any exposed adhesive when the flap is in the sealed or closed position
 - Have bent corners
 - Have rough, cockle, or laid finishes
- Adjust the width guides to fit the width of the envelopes.

Note: A combination of high humidity (over 60%) and the high printing temperature may wrinkle or seal envelopes.

Tips on using labels

Print samples on the labels being considered for use before buying large quantities.

Note: Single-sided paper labels designed for laser printers are supported for occasional use. It is recommended to print 20 or fewer pages of paper labels a month. Vinyl, pharmacy, and dual-sided labels are not supported.

When printing on labels:

- Use labels designed specifically for laser printers. Check with the manufacturer or vendor to verify that:
 - The labels can withstand temperatures up to 210°C (410°F) without sealing, excessive curling, wrinkling, or releasing hazardous emissions.

Note: Labels can be printed at a higher fusing temperature up to 220°C (428°F) if Label Weight is set to Heavy. Select this setting using the Embedded Web Server, or from the printer control panel Paper menu.
 - Label adhesives, face sheet (printable stock), and topcoats can withstand up to 25 psi (172 kPa) pressure without delaminating, oozing around the edges, or releasing hazardous fumes.
- Do not use labels with slick backing material.
- Use full label sheets. Partial sheets may cause labels to peel off during printing, resulting in a jam. Partial sheets also contaminate the printer and the cartridge with adhesive, and could void the printer and cartridge warranties.
- Do not use labels with exposed adhesive.
- Do not print within 1 mm (0.04 in.) of the edge of the label, of the perforations, or between die-cuts of the label.
- Be sure adhesive backing does not reach to the sheet edge. Zone coating of the adhesive at least 1 mm (0.04 in.) away from edges is recommended. Adhesive material contaminates the printer and could void the warranty.
- If zone coating of the adhesive is not possible, remove a 1.6 mm (0.06 in.) strip on the leading and driver edge, and use a non-oozing adhesive.
- Portrait orientation works best, especially when printing bar codes.

Tips on using card stock

Card stock is heavy, single-ply specialty media. Many of its variable characteristics, such as moisture content, thickness, and texture, can significantly impact print quality. Print samples on the card stock being considered for use before buying large quantities.

When printing on card stock:

- Make sure the Paper Type is Card Stock.
- Select the appropriate Paper Texture setting.
- Be aware that preprinting, perforation, and creasing may significantly affect the print quality and cause jams or other paper handling problems.
- Check with the manufacturer or vendor to ensure the card stock can withstand temperatures up to 210°C (410°F) without releasing hazardous emissions.
- Do not use preprinted card stock manufactured with chemicals that may contaminate the printer. Preprinting introduces semi-liquid and volatile components into the printer.
- Use grain short card stock when possible.

Printing confidential and other held jobs

Holding jobs in the printer

When sending a job to the printer, you can specify that you want the printer to hold the job in memory until you start the job from the printer control panel. All print jobs that can be initiated by the user at the printer are called *held jobs*.

Note: Confidential, Verify, Reserve, and Repeat print jobs may be deleted if the printer requires extra memory to process additional held jobs.

Job type	Description
Confidential	When you send a Confidential print job to the printer, you must create a PIN from the computer. The PIN must be four digits using the numbers 0–9. The job is held in printer memory until you enter the PIN from the printer control panel and choose to print or delete the job.
Verify	When you send a Verify print job, the printer prints one copy and holds the remaining copies in printer memory. Verify lets you examine the first copy to see if it is satisfactory before printing the remaining copies. Once all copies are printed, the job is automatically deleted from printer memory.
Reserve	When you send a Reserve print job, the printer does not print the job immediately. It stores the job in memory so you can print the job later. The job is held in memory until you delete it from the Held Jobs menu.
Repeat	When you send a Repeat print job, the printer prints all requested copies of the job <i>and</i> stores the job in memory so you can print additional copies later. You can print additional copies as long as the job remains stored in memory.

Other types of held jobs include:

- Profiles from various sources including Lexmark Document Solutions Suite (LDSS)
- Forms from a kiosk

- Bookmarks
- Jobs not printed, which are called *parked jobs*

Printing confidential and other held jobs from Windows

Note: Confidential and Verify print jobs are automatically deleted from memory after they print. Repeat and Reserve jobs continue to be held in the printer until you choose to delete them.

- 1 With a document open, click **File > Print**.
- 2 Click **Properties, Preferences, Options, or Setup**.
- 3 Click **Other Options**, and then click **Print and Hold**.
- 4 Select your job type (Confidential, Reserve, Repeat, or Verify), and then assign a user name. For a confidential job, also enter a four-digit PIN.
- 5 Click **OK** or **Print**, and then go to the printer to release the job.
- 6 On the home screen, touch **Held jobs**.
- 7 Touch your user name.
Note: A maximum of 500 results can be displayed for held jobs. If your name does not appear, touch the down arrow until your name appears, or touch **Search Held Jobs** if there are a large number of held jobs in the printer.
- 8 Touch **Confidential Jobs**.
- 9 Enter your PIN.
- 10 Touch **Done**.
- 11 Touch the job you want to print.
- 12 Touch **Print**, or touch the arrows to increase or decrease the number of copies, and then touch **Print**.

Printing confidential and other held jobs from a Macintosh computer

Note: Confidential and Verify print jobs are automatically deleted from memory after they print. Repeat and Reserve jobs continue to be held in the printer until you choose to delete them.

- 1 With a document open, choose **File > Print**.
If necessary, click the disclosure triangle to see more options.
- 2 From the print options or Copies & Pages pop-up menu, choose **Job Routing**.
- 3 Select your job type (Confidential, Reserve, Repeat, or Verify), and then assign a user name. For a confidential job, also enter a four-digit PIN.
- 4 Click **OK** or **Print**, and then go to the printer to release the job.
- 5 On the home screen, touch **Held jobs**.
- 6 Touch your user name.
Note: A maximum of 500 results can be displayed for held jobs. If your name does not appear, touch the down arrow until your name appears, or touch **Search Held Jobs** if there are a large number of held jobs in the printer.
- 7 Touch **Confidential Jobs**.

- 8 Enter your PIN.
- 9 Touch the job you want to print.
- 10 Touch **Print**, or touch the arrows to increase or decrease the number of copies, and then touch **Print**.

Printing from a flash drive

A USB port is located on the printer control panel. Insert a flash drive to print supported file types. Supported file types include: .pdf, .gif, .jpeg, .jpg, .bmp, .png, .tiff, .tif, .pcx, and .dcm.

The following flash drives are tested and approved for use with the printer:

- Lexar FireFly (512 MB or 1GB)
- SanDisk Cruizer Micro (512 MB or 1 GB)
- Sony (512 MB or 1GB)

Notes:

- Hi-Speed flash drives must support the USB 2.0 specification, specifically supporting the High Speed mode.
- USB devices must support the FAT (*File Allocation Tables*) system. Flash drives formatted with NTFS (*New Technology File System*) or any other file system are not supported.
- Before printing an encrypted .pdf file, you will be prompted to enter the file password from the printer control panel.
- You cannot print files for which you do not have printing permissions.
- Some USB drives and USB hubs are not supported.

To print from a flash drive:

- 1 Make sure the printer is on and **Ready** appears.
- 2 Insert a flash drive into the USB port.



Notes:

- If you insert the flash drive when the printer requires attention, such as when a jam has occurred, then the printer ignores the flash drive.
- If you insert the flash drive while the printer is printing other jobs, then **Printer Busy** appears. When the current job is completed, touch the USB icon to print documents from the flash drive.

3 Touch the document you want to print.

Note: Folders found on the flash drive appear as folders. File names are appended by the extension type (for example, .jpg).

4 Touch the arrows if you want to increase the number of printed copies.

5 Touch **Print**.



Note: Do not remove the flash drive from the USB port until the document has finished printing.

If you leave the flash drive in the printer after leaving the initial USB menu screen, but you still want to print files from the flash drive, then go to the home screen, touch the USB icon, and print the files.

Printing information pages

Printing a font sample list

To print samples of the fonts currently available for your printer:

- 1** Make sure the printer is on and **Ready** appears.
- 2** On the home screen, touch .
- 3** Touch **Reports**.
- 4** Touch the down arrow until **Print Fonts** appears.
- 5** Touch **Print Fonts**.
- 6** Touch **PCL Fonts** or **PostScript Fonts**.
A font sample list prints.
- 7** Touch  to return to the home screen.



Printing a directory list

A directory list shows the resources stored in flash memory or on the printer hard disk.

- 1** Make sure the printer is on and **Ready** appears.
- 2** On the home screen, touch .
- 3** Touch **Reports**.
- 4** Touch the down arrow until **Print Directory** appears.
- 5** Touch **Print Directory**.

Printing the print quality test pages

Print the print quality test pages to isolate print quality problems.

- 1 Turn the printer off.
- 2 Hold down  and  while turning the printer on.
- 3 Release the buttons when the screen with the progress bar appears.
The printer performs a power-on sequence, and then the Configuration menu appears.
- 4 Touch the down arrow until **Print Quality Pages** appears.
- 5 Touch **Print Quality Pages**.
The print quality test pages print.
- 6 Touch **Back**.
- 7 Touch **Exit Config menu**.

Canceling a print job

Canceling a print job from the printer control panel

- 1 Touch **Cancel Jobs** on the touch screen, or press  on the keypad.
- 2 Touch the job you want to cancel.
- 3 Touch **Delete Selected Jobs**.

Canceling a print job from the computer

To cancel a print job, do one of the following:

For Windows users

- 1 Click , or click **Start** and then click **Run**.
- 2 In the Start Search or Run box, type **control printers**.
- 3 Press **Enter**, or click **OK**.
The printer folder opens.
- 4 Double-click the printer icon.
- 5 Select the job to cancel.
- 6 From the keyboard, press **Delete**.

From the Windows taskbar:

When you send a job to print, a small printer icon appears in the right corner of the taskbar.

- 1 Double-click the printer icon.
A list of print jobs appears in the printer window.
- 2 Select a job to cancel.
- 3 From the keyboard, press **Delete**.

For Macintosh users

In Mac OS X version 10.5 or later:

- 1 From the Apple menu, choose **System Preferences**.
- 2 Click **Print & Fax**, and then double-click the printer icon.
- 3 From the printer window, select the job to cancel.
- 4 From the icon bar at the top of the window, click the **Delete** icon.

In Mac OS X version 10.4 and earlier:

- 1 From the Go menu, choose **Applications**.
- 2 Double-click **Utilities**, and then double-click **Print Center** or **Printer Setup Utility**.
- 3 Double-click the printer icon.
- 4 From the printer window, select the job to cancel.
- 5 From the icon bar at the top of the window, click the **Delete** icon.

Copying

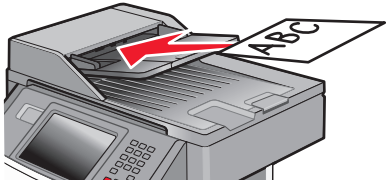
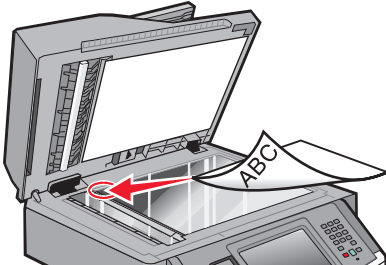
ADF	Scanner glass
	
<p>Use the ADF for multiple-page documents.</p>	<p>Use the scanner glass for single pages, small items (such as postcards or photos), transparencies, photo paper, or thin media (such as magazine clippings).</p>

Making copies

Making a quick copy

- 1 Load an original document faceup, short edge first into the ADF or facedown on the scanner glass.
Note: Do not load postcards, photos, small items, transparencies, photo paper, or thin media (such as magazine clippings) into the ADF. Place these items on the scanner glass.
- 2 If you are loading a document into the ADF, then adjust the paper guides.
- 3 From the printer control panel, press .
- 4 If you placed the document on the scanner glass, then touch **Finish the Job** to return to the home screen.

Copying using the ADF

- 1 Load an original document faceup, short edge first into the ADF.
Note: Do not load postcards, photos, small items, transparencies, photo paper, or thin media (such as magazine clippings) into the ADF. Place these items on the scanner glass.
- 2 Adjust the paper guides.
- 3 On the home screen, touch **Copy**, or use the keypad to enter the number of copies.
 The copy screen appears.
- 4 Change the copy settings as needed.
- 5 Touch **Copy It**.

Copying using the scanner glass

- 1 Place an original document facedown on the scanner glass in the upper left corner.
- 2 On the home screen, touch **Copy**, or use the keypad to enter the number of copies.
The copy screen appears.
- 3 Change the copy settings as needed.
- 4 Touch **Copy It**.
- 5 If you have more pages to scan, then place the next document on the scanner glass, and then touch **Scan the Next Page**.
- 6 Touch **Finish the Job** to return to the home screen.

Copying photos

- 1 Place a photo facedown on the scanner glass in the upper left corner.
- 2 On the home screen, touch **Copy**.
- 3 Touch the **Content** arrows until **Photograph** appears.
- 4 Touch **Copy It**.
- 5 Touch **Scan the Next Page** or **Finish the Job**.

Copying on specialty media

Making transparencies

- 1 Load an original document faceup, short edge first into the ADF or facedown on the scanner glass.
Note: Do not load postcards, photos, small items, transparencies, photo paper, or thin media (such as magazine clippings) into the ADF. Place these items on the scanner glass.
- 2 If you are loading a document into the ADF, then adjust the paper guides.
- 3 On the home screen, touch **Copy**.
- 4 Touch **Copy from**, and then identify the size of the original document.
- 5 Touch **Copy to**, and then touch the tray that contains transparencies, or touch **Manual Feeder** and then place transparencies in the multipurpose feeder.
- 6 Touch the desired size of the transparencies, and then touch **Continue**.
- 7 Touch the arrows until **Transparency** appears.
- 8 Touch **Transparency**, and then touch **Continue**.
- 9 Touch **Copy It**.

Copying to letterhead

- 1 Load an original document faceup, short edge first into the ADF or facedown on the scanner glass.
Note: Do not load postcards, photos, small items, transparencies, photo paper, or thin media (such as magazine clippings) into the ADF. Place these items on the scanner glass.
- 2 If you are loading a document into the ADF, then adjust the paper guides.
- 3 On the home screen, touch **Copy**.
- 4 Touch **Copy from**, and then identify the size of the original document.
- 5 Touch **Copy to**, and then touch **Manual Feeder** and place letterhead face up, top edge first in the multipurpose feeder.
- 6 Touch the desired size of the letterhead, and then touch **Continue**.
- 7 Touch the arrows until **Letterhead** appears.
- 8 Touch **Letterhead**, and then touch **Continue**.
- 9 Touch **Copy It**.

Customizing copy settings

Copying from one size to another

- 1 Load an original document faceup, short edge first into the ADF or facedown on the scanner glass.
Note: Do not load postcards, photos, small items, transparencies, photo paper, or thin media (such as magazine clippings) into the ADF. Place these items on the scanner glass.
- 2 If you are loading a document into the ADF, then adjust the paper guides.
- 3 On the home screen, touch **Copy**.
- 4 Touch **Copy from**, and then identify the size of the original document.
- 5 Touch **Copy to**, and then select the size you want the copy to be.
Note: If you select a paper size that is different from the “Copy from” size, then the printer will scale the size automatically.
- 6 Touch **Copy It**.

Making copies using paper from a selected tray

During the copy process, you can select the tray that contains the paper type of choice.

- 1 Load an original document faceup, short edge first into the ADF or facedown on the scanner glass.
Note: Do not load postcards, photos, small items, transparencies, photo paper, or thin media (such as magazine clippings) into the ADF. Place these items on the scanner glass.
- 2 If you are loading a document into the ADF, then adjust the paper guides.
- 3 On the home screen, touch **Copy**.

- 4 Touch **Copy from**, and then identify the size of the original document.
- 5 Touch **Copy to**, and then touch the tray or feeder that contains the paper type you want.
Note: If you choose Manual Feeder, then you will also need to select the paper size and type.
- 6 Touch **Copy It**.

Copying on both sides of the paper (duplexing)

- 1 Load an original document faceup, short edge first into the ADF or facedown on the scanner glass.
Note: Do not load postcards, photos, small items, transparencies, photo paper, or thin media (such as magazine clippings) into the ADF. Place these items on the scanner glass.
- 2 If you are loading a document into the ADF, then adjust the paper guides.
- 3 On the home screen, touch **Copy**.
- 4 From the Sides (Duplex) area, touch the button that looks the way you want your copies duplexed.
The first number represents sides of the original documents; the second number represents sides of the copy. For example, select 1-sided to 2-sided if you have 1-sided original documents and you want 2-sided copies.
Note: The ADF automatically scans both sides of the page.
- 5 Touch **Copy It**.

Reducing or enlarging copies

Copies can be reduced to 25% of the original document size or enlarged to 400% of the original document size. The factory default setting for Scale is Auto. If you leave Scale set to Auto, the content of your original document will be scaled to fit the size of the paper onto which you are copying.

To reduce or enlarge a copy:

- 1 Load an original document faceup, short edge first into the ADF or facedown on the scanner glass.
Note: Do not load postcards, photos, small items, transparencies, photo paper, or thin media (such as magazine clippings) into the ADF. Place these items on the scanner glass.
- 2 If you are loading a document into the ADF, then adjust the paper guides.
- 3 On the home screen, touch **Copy**.
- 4 From the Scale area, touch the arrows to enlarge or reduce your copies.
Touching "Copy to" or "Copy from" after setting Scale manually changes the scale value back to Auto.
- 5 Touch **Copy It**.

Adjusting copy quality

- 1 Load an original document faceup, short edge first into the ADF or facedown on the scanner glass.
Note: Do not load postcards, photos, small items, transparencies, photo paper, or thin media (such as magazine clippings) into the ADF. Place these items on the scanner glass.
- 2 If you are loading a document into the ADF, then adjust the paper guides.

- 3 On the home screen, touch **Copy**.
- 4 From the Content area, touch the arrows to best represent what you are copying:
 - **Text**—Used for original documents that are mostly text or line art
 - **Text/Photo**—Used when the original documents are a mixture of text and graphics or pictures
 - **Photograph**—Used when the original document is a high-quality photograph or inkjet print
 - **Printed Image**—Used when copying halftone photographs, graphics such as documents printed on a laser printer, or pages from a magazine or newspaper that are composed primarily of images
- 5 Touch **Copy It**.

Collating copies

If you print multiple copies of a document, then you can choose to print each copy as a set (collated) or to print the copies as groups of pages (not collated).

Collated



Not collated



By default, Collate is set to On. If you do not want to collate your copies, then change the setting to Off.

To turn collate off:

- 1 Load an original document faceup, short edge first into the ADF or facedown on the scanner glass.

Note: Do not load postcards, photos, small items, transparencies, photo paper, or thin media (such as magazine clippings) into the ADF. Place these items on the scanner glass.
- 2 If you are loading a document into the ADF, then adjust the paper guides.
- 3 On the home screen, touch **Copy**.
- 4 Use the keypad to enter the number of copies.
- 5 Touch **Off** if you do not want your copies collated.
- 6 Touch **Copy It**.

Placing separator sheets between copies

- 1 Load an original document faceup, short edge first into the ADF or facedown on the scanner glass.

Note: Do not load postcards, photos, small items, transparencies, photo paper, or thin media (such as magazine clippings) into the ADF. Place these items on the scanner glass.
- 2 If you are loading a document into the ADF, then adjust the paper guides.
- 3 On the home screen, touch **Copy**.
- 4 Touch **Options**.

5 Touch Separator Sheets.

Note: Collate must be On for the separator sheets to be placed between copies. If Collate is Off, the separator sheets are added to the end of the print job.

6 Select one of the following:

- **Between Copies**
- **Between Jobs**
- **Between Pages**

7 Touch Done.**8 Touch Copy It.**

Copying multiple pages onto a single sheet

In order to save paper, you can copy either two or four consecutive pages of a multiple-page document onto a single sheet of paper.

Notes:

- The Paper Size must be set to Letter, Legal, A4, or B5 JIS.
- The Copy Size must be set to 100%.

1 Load an original document faceup, short edge first into the ADF or facedown on the scanner glass.

Note: Do not load postcards, photos, small items, transparencies, photo paper, or thin media (such as magazine clippings) into the ADF. Place these items on the scanner glass.

2 If you are loading a document into the ADF, then adjust the paper guides.**3 On the home screen, touch Copy.****4 Select a duplex setting.****5 Touch Options.****6 Touch Paper Saver.****7 Select the desired output.****8 Touch Print Page Borders if you want a box drawn around each page of the copies.****9 Touch Done.****10 Touch Copy It.**

Creating a custom job (job build)

The custom job or job build is used to combine one or more sets of original documents into a single copy job. Each set may be scanned using different job parameters. When a copy job is submitted and Custom Job is enabled, the scanner scans the first set of original documents using the supplied parameters, and then it scans the next set with the same or different parameters.

The definition of a set depends on the scan source:

- If you scan a document on the scanner glass, a set consists of one page.
- If you scan multiple pages using the ADF, a set consists of all scanned pages until the ADF becomes empty.

- If you scan one page using the ADF, a set consists of one page.

For example:

- 1 Load an original document faceup, short edge first into the ADF or facedown on the scanner glass.
Note: Do not load postcards, photos, small items, transparencies, photo paper, or thin media (such as magazine clippings) into the ADF. Place these items on the scanner glass.
- 2 If you are loading a document into the ADF, then adjust the paper guides.
- 3 On the home screen, touch **Copy**.
- 4 Touch **Options**.
- 5 Touch **Custom Job**.
- 6 Touch **On**.
- 7 Touch **Done**.
- 8 Touch **Copy It**.
When the end of a set is reached, the scan screen appears.
- 9 Load the next document faceup, short edge first into the ADF or facedown on the scanner glass, and then touch **Scan the Automatic Document Feeder** or **Scan the flatbed**.
Note: If required, change the job settings.
- 10 If you have another document to scan, load the next document faceup, short edge first into the ADF or facedown on the scanner glass, and then touch **Scan the Automatic Document Feeder** or **Scan the flatbed**. Otherwise, touch **Finish the job**.

Pausing the current print job to make copies

When the “Allow priority copies” setting is On, the printer pauses the current print job when you start a copy job.

Note: The “Allow priority copies” setting must be set to On in the Copy Settings menu so that you can pause the current print job and make copies.

- 1 Load an original document faceup, short edge first into the ADF or facedown on the scanner glass.
Note: Do not load postcards, photos, small items, transparencies, photo paper, or thin media (such as magazine clippings) into the ADF. Place these items on the scanner glass.
- 2 If you are loading a document into the ADF, then adjust the paper guides.
- 3 From the printer control panel, press .
- 4 If you placed the document on the scanner glass, then touch **Finish the Job** to return to the home screen.

Placing information on copies

Placing the date and time at the top of each page

- 1 Load an original document faceup, short edge first into the ADF or facedown on the scanner glass.
Note: Do not load postcards, photos, small items, transparencies, photo paper, or thin media (such as magazine clippings) into the ADF. Place these items on the scanner glass.
- 2 If you are loading a document into the ADF, then adjust the paper guides.
- 3 On the home screen, touch **Copy**.
- 4 Touch **Options**.
- 5 Touch **Header/Footer**.
- 6 Pick an area of the page to place the date and time.
- 7 Touch **Date/Time**, and then touch **Continue**.
- 8 Touch **Done**.
- 9 Touch **Copy It**.

Placing an overlay message on each page

An overlay message can be placed on each page. The message choices are Urgent, Confidential, Copy, or Draft. To place a message on the copies:

- 1 Load an original document faceup, short edge first into the ADF or facedown on the scanner glass.
Note: Do not load postcards, photos, small items, transparencies, photo paper, or thin media (such as magazine clippings) into the ADF. Place these items on the scanner glass.
- 2 If you are loading a document into the ADF, then adjust the paper guides.
- 3 On the home screen, touch **Copy**.
- 4 Touch **Options**.
- 5 Touch **Overlay**.
- 6 Touch the button containing the overlay you want to use.
- 7 Touch **Done**.
- 8 Touch **Copy It**.

Canceling a copy job

Canceling a copy job while the document is in the ADF

When the ADF begins processing a document, the scanning screen appears. To cancel the copy job, touch **Cancel Job** on the touch screen.

A “Canceling scan job” screen appears. The ADF clears all pages in the ADF and cancels the job.

Canceling a copy job while copying pages using the scanner glass

Touch **Cancel Job** on the touch screen.

A “Canceling scan job” screen appears. Once the job is canceled, the copy screen appears.

Canceling a copy job while the pages are being printed

- 1 Touch **Cancel Job** on the touch screen, or press  on the keypad.
- 2 Touch the job you want to cancel.
- 3 Touch **Delete Selected Jobs**.

The remainder of the copy job is canceled. The home screen appears.

Understanding the copy screens and options

Copy from

This option opens a screen where you can enter the size of the documents you are going to copy. Touch a paper size button to select it as the “Copy from” setting. The copy screen appears with your new setting displayed.

Copy to

This option opens a screen where you can enter the size and type of paper on which your copies will be printed.

- Touch a paper size button to select it as the “Copy to” setting. The copy screen appears with your new setting displayed.
- If the size settings for “Copy from” and “Copy to” are different, the printer automatically adjusts the Scale setting to accommodate the difference.
- If the type or size of paper that you want to copy onto is not loaded in one of the trays, touch **Manual Feeder**, and manually send the paper through the multipurpose feeder.
- When “Copy to” is set to Auto Size Match, each copy matches the size of the original document. If a matching paper size is not in one of the trays, the printer scales each copy to fit loaded paper.

Scale

This option creates an image from your copy that is proportionally scaled anywhere between 25% and 400%. Scale can also be set for you automatically.

- When you want to copy from one size of paper to another, such as from legal-size to letter-size paper, setting the “Copy from” and “Copy to” paper sizes automatically changes the scale to keep all the original document information on your copy.
- Touch the left arrow to decrease the value by 1%; touch the right arrow to increase the value by 1%.
- Hold your finger on an arrow to make a continuous increment change.
- Hold your finger on an arrow for two seconds to cause the pace of the change to accelerate.

Darkness

This option adjusts how light or dark your copies will turn out in relation to the original document.

Content

This option tells the printer the original document type. Choose from Text, Text/Photo, Photograph, or Printed Image.

- **Text**—Emphasize sharp, black, high-resolution text against a clean, white background
- **Text/Photo**—Used when the original documents are a mixture of text and graphics or pictures
- **Photograph**—Tells the scanner to pay extra attention to graphics and pictures. This setting increases the time it takes to scan, but emphasizes a reproduction of the full dynamic range of tones in the original document.
- **Printed Image**—Used when copying halftone photographs, graphics such as documents printed on a laser printer, or pages from a magazine or newspaper that are composed primarily of images

Sides (Duplex)

Use this option to select duplex settings. You can print copies on one or two sides, make two-sided copies (duplex) of two-sided original documents, make two-sided copies from one-sided original documents, or make one-sided copies (simplex) from two-sided original documents.

Collate

This option keeps the pages of a print job stacked in sequence when printing multiple copies of the document. The factory default setting for Collate is on; the output pages of your copies will be ordered (1,2,3) (1,2,3) (1,2,3). If you want all the copies of each page to remain together, turn Collate off, and your copies will be ordered (1,1,1) (2,2,2) (3,3,3).

Options

Touching the Options button opens a screen where you can change Paper Saver, Create Booklet, Advanced Imaging, Custom Job, Separator Sheets, Margin Shift, Edge Erase, Header/Footer, Overlay, Advanced Duplex, and Save as Shortcut settings.

Paper Saver

This option lets you print two or more sheets of an original document together on the same page. Paper Saver is also called N-up printing. The N stands for Number. For example, 2-up would print two pages of your document on a single page, and 4-up would print four pages of your document on a single page. Touching Print Page Borders adds or removes the outline border surrounding the original document pages on the output page.

Create Booklet

This option creates a stack of collated pages that, when folded, forms a booklet half the page size of the original document and with all the pages in order.

Note: To use Create Booklet, you must have a duplex unit attached to the printer.

Advanced Imaging

This option lets you adjust Background Removal, Color Dropout, Contrast, Mirror Image, Negative Image, Shadow Detail, Scan Edge to Edge, and sharpness before you copy the document.

Custom Job

This option combines multiple scanning jobs into a single job.

Separator Sheets

This option places a blank piece of paper between copies, pages, and print jobs. The separator sheets can be drawn from a tray that contains a type or color of paper that is different from the paper your copies are printed on.

Margin Shift

This option increases the size of the margin a specified distance. This can be useful in providing space to bind or hole-punch copies. Use the increase or decrease arrows to set how much of a margin you want. If the additional margin is too large, then the copy will be cropped.

Edge Erase

This option eliminates smudges or information around the edges of your document. You can choose to eliminate an equal area around all four sides of the paper, or pick a particular edge. Edge Erase erases whatever is within the selected area, leaving nothing printed on that portion of the paper.

Header/Footer

This option turns on the Date/Time, Page number, Bates number, or Custom text and prints them in the specified header or footer location.

Overlay

This option creates a watermark (or message) that overlays the content of your copy. You can choose between Urgent, Confidential, Copy, and Draft, or you can enter a custom message in the "Enter custom text" field. The word you pick will appear, faintly, in large print across each page.

Note: A custom overlay can also be created by your system support person. When a custom overlay is created, a button with an icon of that overlay will be available.

Advanced Duplex

This option controls whether the documents are one-sided or two-sided, what orientation your original documents have, and how your documents are bound.

Note: Some Advanced Duplex options may not be available on all printer models.

Save as Shortcut

This option allows the current settings to be saved as a shortcut.

Improving copy quality

Question	Tip
When should I use Text mode?	<ul style="list-style-type: none">• Use text mode when text preservation is the main goal of the copy, and preserving images copied from the original document is not a concern.• Text mode is recommended for receipts, carbon copy forms, and documents that contain only text or fine line art.
When should I use Text/Photo mode?	<ul style="list-style-type: none">• Use Text/Photo mode when copying an original document that contains a mixture of text and graphics.• Text/Photo mode is recommended for magazine articles, business graphics, and brochures.
When should I use Printed Image mode?	Use Printed Image mode when copying halftone photographs, graphics such as documents printed on a laser printer, or pages from a magazine or newspaper
When should I use Photograph mode?	Use Photograph mode when the original document is a high-quality photograph or inkjet print.

E-mailing

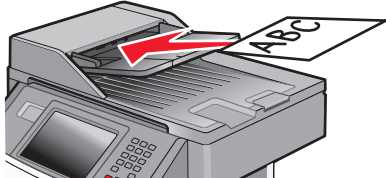
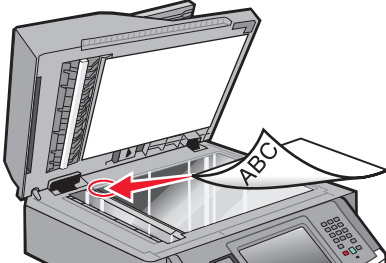
ADF	Scanner glass
	
Use the ADF for multiple-page documents.	Use the scanner glass for single pages, small items (such as postcards or photos), transparencies, photo paper, or thin media (such as magazine clippings).

Getting ready to e-mail

Enabling the e-mail function

The e-mail function must be enabled prior to use. If you disabled the e-mail function when setting up the printer for the first time, or if the printer has been off for an extended time, then follow these steps:

Note: To complete this step, you must know your Primary SMTP (mail server) Gateway address. For more information, see your system support person.

- 1 Touch **Menus**.
- 2 Touch **Settings**.
- 3 Touch **General Settings**.
- 4 Touch the left or right arrow next to **Run initial setup** to select **Yes**.
- 5 Touch **Submit**.
Submitting changes appears.
- 6 Turn off the printer, wait ten seconds, and then turn the printer back on.
- 7 From the printer control panel, select your language.
- 8 Select your country or region, and then touch **Continue**.
- 9 Select your time zone, and then touch **Continue**.
- 10 Touch **E-mail**, and then touch **Continue**.
- 11 Select any additional buttons you want to display on the home screen, and then touch **Continue**.
- 12 Touch **Enter**.
- 13 Touch **Continue**.

- 14 Type in the Primary SMTP Gateway address, and then touch **Enter**.
- 15 If prompted, set the date and time, and then touch **Continue**.
When the home screen appears, the e-mail function is enabled.

Setting up the e-mail function

For e-mail to operate, it must be turned on in the printer configuration and have a valid IP address or gateway address. To set up the e-mail function:

- 1 Type the printer IP address into the address field of your Web browser.
Note: If you do not know the IP address of the printer, then print a network setup page and locate the IP address in the TCP/IP section.
- 2 Click **Settings**.
- 3 Under Default Settings, click **E-mail/FTP Settings**.
- 4 Click **E-mail Settings**.
- 5 Click **Setup E-mail Server**.
- 6 Fill in the fields with the appropriate information.
- 7 Click **Add**.

Configuring the e-mail settings

- 1 Type the printer IP address into the address field of your Web browser.
Note: If you do not know the IP address of the printer, then print a network setup page and locate the IP address in the TCP/IP section.
- 2 Click **Settings**.
- 3 Click **E-mail/FTP Settings**.
- 4 Click **E-mail Settings**.
- 5 Fill in the fields with the appropriate information.
- 6 Click **Submit**.

Creating an e-mail shortcut

Creating an e-mail shortcut using the Embedded Web Server

- 1 Type the printer IP address into the address field of your Web browser.
Note: If you do not know the IP address of the printer, then print a network setup page and locate the IP address in the TCP/IP section.
- 2 Click **Settings**.
- 3 Under Other Settings, click **Manage Shortcuts**.

- 4 Click **E-mail Shortcut Setup**.
- 5 Type a unique name for the recipient, and then enter the e-mail address.
Note: If you are entering multiple addresses, then separate each address with a comma (,).
- 6 Select the scan settings (Format, Content, Color, and Resolution).
- 7 Enter a shortcut number, and then click **Add**.
If you enter a number that is already in use, then you are prompted to select another number.

Creating an e-mail shortcut using the touch screen

- 1 On the home screen, touch **E-mail**.
- 2 Type the recipient's e-mail address.
To create a group of recipients, touch **Next address**, and then type the next recipient's e-mail address.
- 3 Touch **Save as Shortcut**.
- 4 Type a unique name for the shortcut, and then touch **Enter**.
- 5 Verify that the shortcut name and number are correct, and then touch **OK**.
If the name or number is incorrect, then touch **Cancel**, and then reenter the information.

E-mailing a document

Sending an e-mail using the touch screen

- 1 Load an original document faceup, short edge first into the ADF or facedown on the scanner glass.
Note: Do not load postcards, photos, small items, transparencies, photo paper, or thin media (such as magazine clippings) into the ADF. Place these items on the scanner glass.
- 2 If you are loading a document into the ADF, then adjust the paper guides.
- 3 On the home screen, touch **E-mail**.
- 4 Enter the e-mail address or shortcut number.
To enter additional recipients, touch **Next Address**, and then enter the address or shortcut number you want to add.
- 5 Touch **E-mail It**.

Sending an e-mail using a shortcut number

- 1 Load an original document faceup, short edge first into the ADF or facedown on the scanner glass.
Note: Do not load postcards, photos, small items, transparencies, photo paper, or thin media (such as magazine clippings) into the ADF. Place these items on the scanner glass.
- 2 If you are loading a document into the ADF, then adjust the paper guides.

- 3 Press **#**, and then enter the shortcut number using the keypad.

To enter additional recipients, press **Next address**, and then enter the address or shortcut number you want to add.

- 4 Touch **E-mail It**.

Sending an e-mail using the address book

- 1 Load an original document faceup, short edge first into the ADF or facedown on the scanner glass.

Note: Do not load postcards, photos, small items, transparencies, photo paper, or thin media (such as magazine clippings) into the ADF. Place these items on the scanner glass.

- 2 If you are loading a document into the ADF, then adjust the paper guides.

- 3 On the home screen, touch **E-mail**.

- 4 Touch **Search Address Book**.

- 5 Enter the name or part of the name you are searching for, and then touch **Search**.

- 6 Touch the name that you want to add to the To box.

To enter additional recipients, press **Next address**, and then enter the address or shortcut number you want to add; or search the address book.

- 7 Touch **E-mail It**.

Customizing e-mail settings

Adding e-mail subject and message information

- 1 Load an original document faceup, short edge first into the ADF or facedown on the scanner glass.

Note: Do not load postcards, photos, small items, transparencies, photo paper, or thin media (such as magazine clippings) into the ADF. Place these items on the scanner glass.

- 2 If you are loading a document into the ADF, then adjust the paper guides.

- 3 On the home screen, touch **E-mail**.

- 4 Type an e-mail address.

- 5 Touch **Options**.

- 6 Touch **Subject**.

- 7 Type the e-mail subject.

- 8 Touch **Done**.

- 9 Touch **Message**.

- 10 Type an e-mail message.

- 11 Touch **Done**.

- 12 Touch **E-mail It**.

Changing the output file type

- 1 Load an original document faceup, short edge first into the ADF or facedown on the scanner glass.

Note: Do not load postcards, photos, small items, transparencies, photo paper, or thin media (such as magazine clippings) into the ADF. Place these items on the scanner glass.

- 2 If you are loading a document into the ADF, then adjust the paper guides.

- 3 On the home screen, touch **E-mail**.

- 4 Type an e-mail address.

- 5 Touch **Options**.

- 6 Touch the button that represents the file type you want to send.

- **PDF**—Creates a single file with multiple pages, viewable with Adobe Reader. Adobe Reader is provided free by Adobe at www.adobe.com.
- **Secure PDF**—Creates an encrypted PDF file that protects the file contents from unauthorized access
- **TIFF**—Creates multiple files or a single file. If Multi-page TIFF is turned off in the Settings menu of the Embedded Web Server, then TIFF saves one page in each file. The file size is usually larger than an equivalent JPEG.
- **JPEG**—Creates and attaches a separate file for each page of your original document, viewable by most Web browsers and graphics programs
- **XPS**—Creates a single XML Paper Specification (XPS) file with multiple pages, viewable using an Internet Explorer-hosted viewer and the .NET Framework, or by downloading a third party standalone viewer

- 7 Touch **E-mail It**.

Note: If you selected Encrypted PDF, then enter your password twice.

Canceling an e-mail

- When using the ADF, touch **Cancel Job** while **Scanning...** appears.
- When using the scanner glass, touch **Cancel Job** while **Scanning...** appears or while **Scan the Next Page / Finish the Job** appears.

Understanding e-mail options

Original Size

This option opens a screen where you can choose the size of the documents you are going to e-mail.

- Touch a paper size button to select that size as the Original Size setting. The e-mail screen appears with your new setting displayed.
- When Original Size is set to Mixed Sizes, you can scan an original document that contains mixed letter and legal paper sizes.

Sides (Duplex)

This option informs the printer if the original document is simplex (printed on one side) or duplex (printed on both sides). This lets the scanner know what needs to be scanned for inclusion in the e-mail.

Orientation

This option tells the printer whether the original document is in portrait or landscape orientation and then changes the Sides and Binding settings to match the original document orientation.

Binding

Tells the printer whether the original document is bound on the long-edge or short-edge side.

E-mail Subject

This option lets you enter a subject line for your e-mail. You can enter up to 255 characters.

E-mail File Name

This option lets you customize the attachment file name.

E-mail Message

This option lets you enter a message that will be sent with your scanned attachment.

Resolution

Adjusts the output quality of your e-mail. Increasing the image resolution increases the e-mail file size and the time needed to scan your original document. Image resolution can be decreased to reduce the e-mail file size.

Send As

This option sets the output (PDF, TIFF, JPEG or XPS) for the scanned image.

- **PDF**—Creates a single file with multiple pages, viewable with Adobe Reader. Adobe Reader is provided free by Adobe at www.adobe.com.
- **Secure PDF**—Creates an encrypted PDF file that protects the file contents from unauthorized access
- **TIFF**—Creates multiple files or a single file. If Multi-page TIFF is turned off in the Settings menu of the Embedded Web Server, then TIFF saves one page in each file. The file size is usually larger than an equivalent JPEG.
- **JPEG**—Creates and attaches a separate file for each page of your original document, viewable by most Web browsers and graphics programs
- **XPS**—Creates a single XPS file with multiple pages, viewable using an Internet Explorer-hosted viewer and the .NET Framework, or by downloading a third party standalone viewer

Content

This option tells the printer the original document type. Choose from Text, Text/Photo, or Photo. Color can be turned on or off with any of the Content choices. Content affects the quality and size of your e-mail.

- **Text**—Emphasizes sharp, black, high-resolution text against a clean, white background
- **Text/Photo**—Used when the original documents are a mixture of text and graphics or pictures

- **Photograph**—Tells the scanner to pay extra attention to graphics and pictures. This setting increases the time it takes to scan, but emphasizes a reproduction of the full dynamic range of tones in the original document. This increases the amount of information saved.
- **Color**—Sets the scan type and output for the e-mail. Color documents can be scanned and sent to an e-mail address.

Advanced Options

Touching this button opens a screen where you change Advanced Imaging, Custom Job, Transmission Log, Scan Preview, Edge Erase, and Darkness settings.

- **Advanced Imaging**—Adjusts Background Removal, Contrast, Scan Edge to Edge, Shadow Detail, and Mirror Image before you copy the document
- **Custom Job (Job Build)**—Combines multiple scanning jobs into a single job
- **Transmission Log**—Prints the transmission log or transmission error log
- **Scan Preview**—Displays the first page of the image before it is included in the e-mail. When the first page is scanned, the scanning is paused and a preview image appears.
- **Edge Erase**—Eliminates smudges or information around the edges of a document. You can choose to eliminate an equal area around all four sides of the paper, or pick a particular edge. Edge Erase will erase whatever is within the area selected, leaving nothing on that portion of the scan.
- **Darkness**—Adjusts how light or dark your scanned e-mails will turn out

Faxing

Note: Fax capabilities may not be available on all printer models.

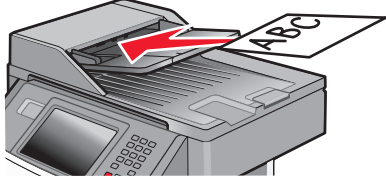
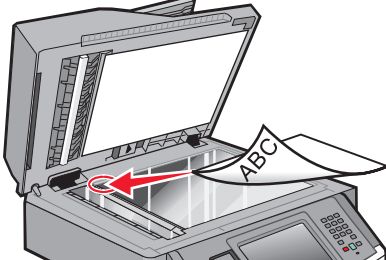
ADF	Scanner glass
	
<p>Use the ADF for multiple-page documents.</p>	<p>Use the scanner glass for single pages, small items (such as postcards or photos), transparencies, photo paper, or thin media (such as magazine clippings).</p>

Getting the printer ready to fax

Note: Fax capabilities may not be available on all printer models.

The following connection methods may not be applicable in all countries or regions.

⚠ CAUTION—SHOCK HAZARD: Do not use the fax feature during a lightning storm. Do not set up this product or make any electrical or cabling connections, such as the fax feature, power cord, or telephone, during a lightning storm.

Setting up the printer to fax

When setting up the printer to fax, you must follow these steps:

- 1 Choose a fax connection type, and then follow the steps for that method. For more information, see “Choosing a fax connection” on page 121.
- 2 Follow the steps for enabling the fax function. For more information, see “Enabling the fax function” on page 132.

Choosing a fax connection

You can connect the printer with equipment such as a telephone, an answering machine, or a computer modem. To determine the best way to set up the printer, see the following table.

Notes:

- The printer is an analog device that works best when directly connected to the wall outlet. Other devices (such as a telephone or answering machine) can be successfully attached to pass through the printer, as described in the setup steps.
- If you want a digital connection such as ISDN, DSL, or ADSL, a third-party device (such as a DSL filter) is required. Contact your DSL provider for a DSL filter. The DSL filter removes the digital signal on the telephone line that can interfere with the ability of the printer to fax properly.
- You *do not* need to attach the printer to a computer, but you *do* need to connect it to an analog telephone line to send and receive faxes.

Equipment and service options	Fax connection setup
Connect directly to the telephone line	See “Connecting to an analog telephone line” on page 122
Connect to a Digital Subscriber Line (DSL or ADSL) service	See “Connecting to a DSL service” on page 123.
Connect to a Private Branch eXchange (PBX) or Integrated Services Digital Network (ISDN) system	See “Connecting to a PBX or ISDN system” on page 123.
Use a Distinctive Ring service	See “Connecting to a distinctive ring service” on page 124.
Connect to a telephone line, telephone, and answering machine	See “Connecting the printer and a telephone or answering machine to the same telephone line” on page 124
Connect through an adapter used in your area	See “Connecting to an adapter for your country or region” on page 126.
Connect to a computer with a modem	See “Connecting to a computer with a modem” on page 131.

Connecting to an analog telephone line

If your telecommunications equipment uses a US-style (RJ11) telephone line, then follow these steps to connect the equipment:

- 1 Connect one end of the telephone cable that came with the printer to the printer LINE port .
- 2 Connect the other end of the telephone cable to an active analog telephone wall jack.

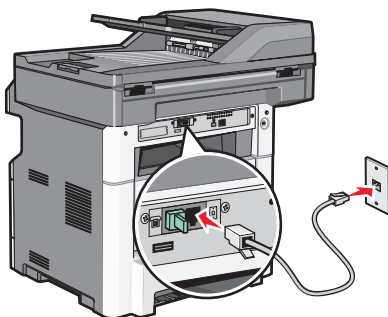

Connecting to a DSL service

If you subscribe to a DSL service, then contact the DSL provider to obtain a DSL filter and telephone cord, and then follow these steps to connect the equipment:

- 1 Connect one end of the telephone cable that came with the printer to the printer LINE port .
- 2 Connect the other end of the telephone cable to the DSL filter.
Note: Your DSL filter may look different than the one in the illustration.
- 3 Connect the DSL filter cable to an active telephone wall jack.

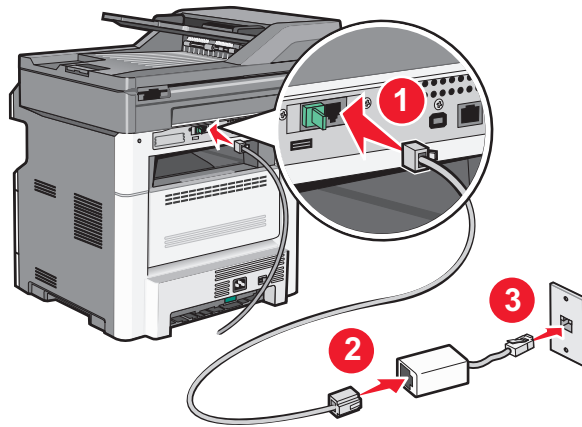

Connecting to a PBX or ISDN system

If you use a PBX or ISDN converter or terminal adapter, then follow these steps to connect the equipment:

- 1 Connect one end of the telephone cable that came with the printer to the printer LINE port .
- 2 Connect the other end of the telephone cable to the port designated for fax and telephone use.

Notes:

- Make sure the terminal adapter is set to the correct switch type for your region.
- Depending on the ISDN port assignment, you may have to connect to a specific port.
- When using a PBX system, make sure the call waiting tone is off.
- When using a PBX system, dial the outside line prefix before dialing the fax number.
- For more information on using the fax with a PBX system, see the documentation that came with your PBX system.

Connecting to a distinctive ring service

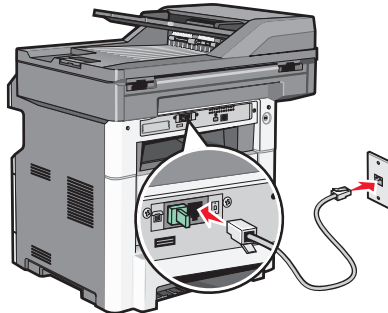

A distinctive ring service may be available from your telephone service provider. This service allows you to have multiple telephone numbers on one telephone line with each telephone number having a different ring pattern. This may be useful for distinguishing between fax and voice calls. If you subscribe to a distinctive ring service, follow these steps to connect the equipment:

- 1 Connect one end of the telephone cable that came with the printer to the printer LINE port .
- 2 Connect the other end of the telephone cable to an active analog telephone wall jack.



- 3 Change the Distinctive Rings setting to match the setting you want the printer to answer:

Note: The factory default setting for distinctive rings is **On**. This allows the printer to answer single, double, and triple ring patterns.

- a On the home screen, touch .
- b Touch **Settings**.
- c Touch **Fax Settings**.
- d Touch **Analog Fax Settings**.
- e Touch  until **Distinctive Rings** appears
- f Touch **Distinctive Rings**.
- g Touch the arrow for the pattern setting you want to change.
- h Touch **Submit**.

Connecting the printer and a telephone or answering machine to the same telephone line

- 1 Connect one end of the telephone cable that came with the printer to the printer LINE port .
- 2 Connect the other end of the telephone cable to an active analog telephone wall jack.

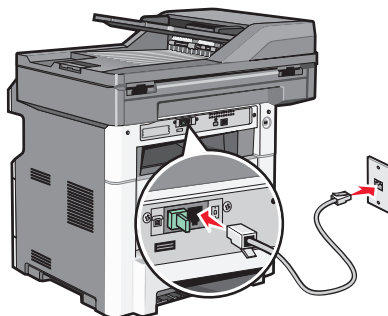

3 Remove the plug from the printer EXT port .

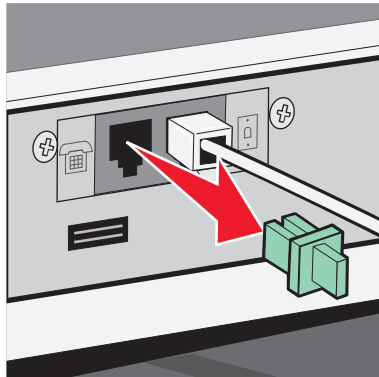

4 Connect your telecommunications equipment directly to the printer EXT port .
Use one of the following methods:

Answering machine

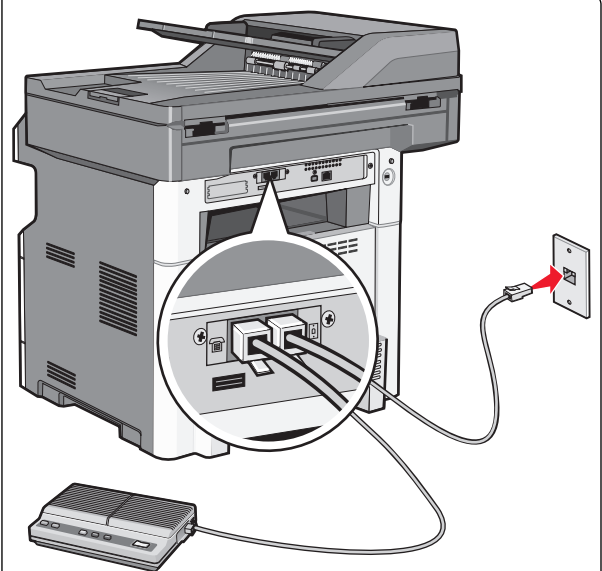

Answering machine and telephone

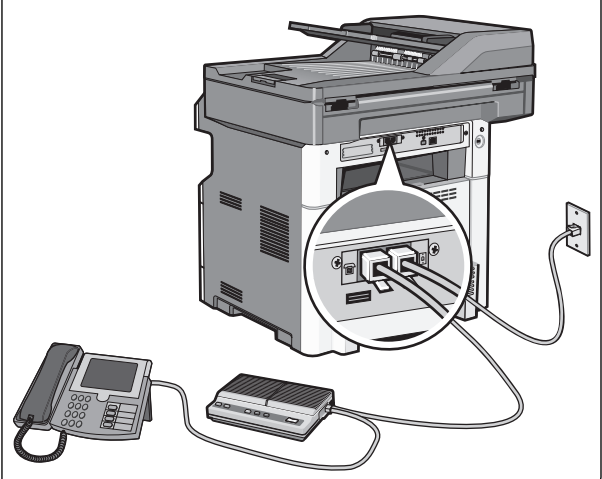

Telephone or a telephone with an integrated answering machine

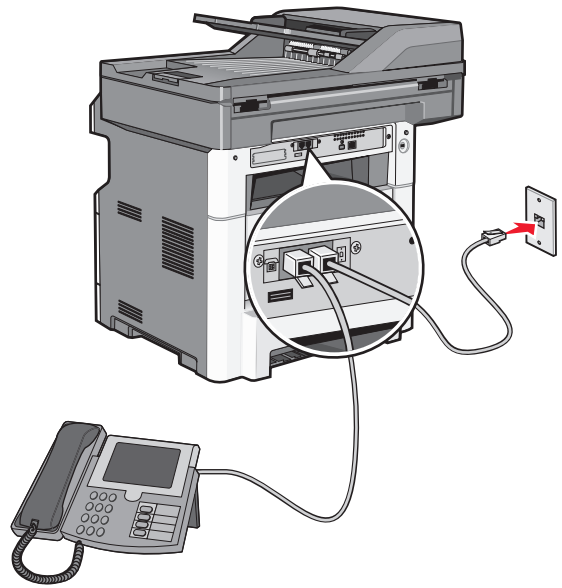

Connecting to an adapter for your country or region

The following countries or regions may require a special adapter to connect the telephone cable to the active telephone wall jack:

Country/region

- Austria
- Cyprus
- Denmark
- Finland
- France
- Germany
- Ireland
- Italy
- New Zealand
- Netherlands
- Norway
- Portugal
- Sweden
- Switzerland
- United Kingdom

Countries or regions except Germany

For some countries or regions, a telephone line adapter is included in the box. Use this adapter to connect an answering machine, telephone, or other telecommunications equipment to the printer.

There is a plug installed in the printer EXT port . This plug is necessary for the proper functioning of the adapter.

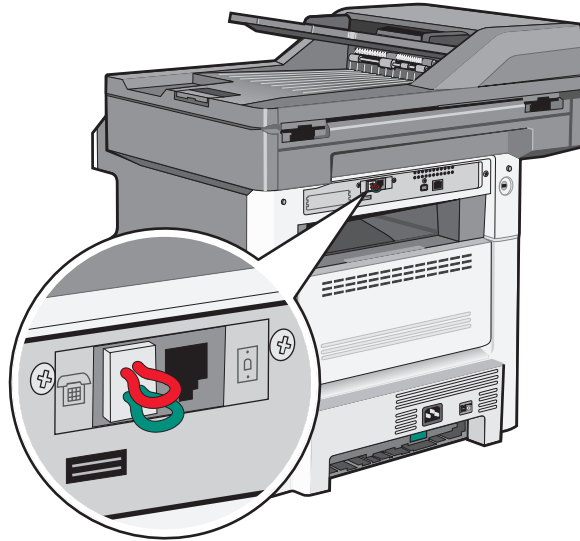

Note: Do not remove the plug if you have a serial phone system or wish to connect a phone or answering machine to the adapter. If you remove it, then other telecommunications devices in your home (such as telephones or answering machines) may not work.

- 1 Connect one end of the telephone cable that came with the printer to the printer LINE port .
- 2 Connect the other end of the telephone cable to the adapter, and then connect the adapter to the active telephone wall jack.

Note: Your telephone adapter may look different than the one shown. It will fit the wall jack used in your location.

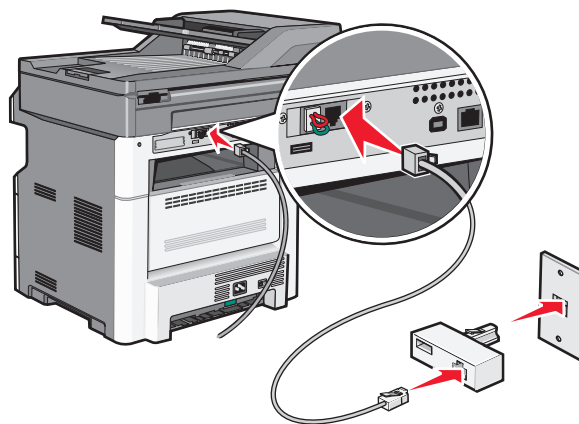

3 Connect the answering machine or telephone to the adapter.

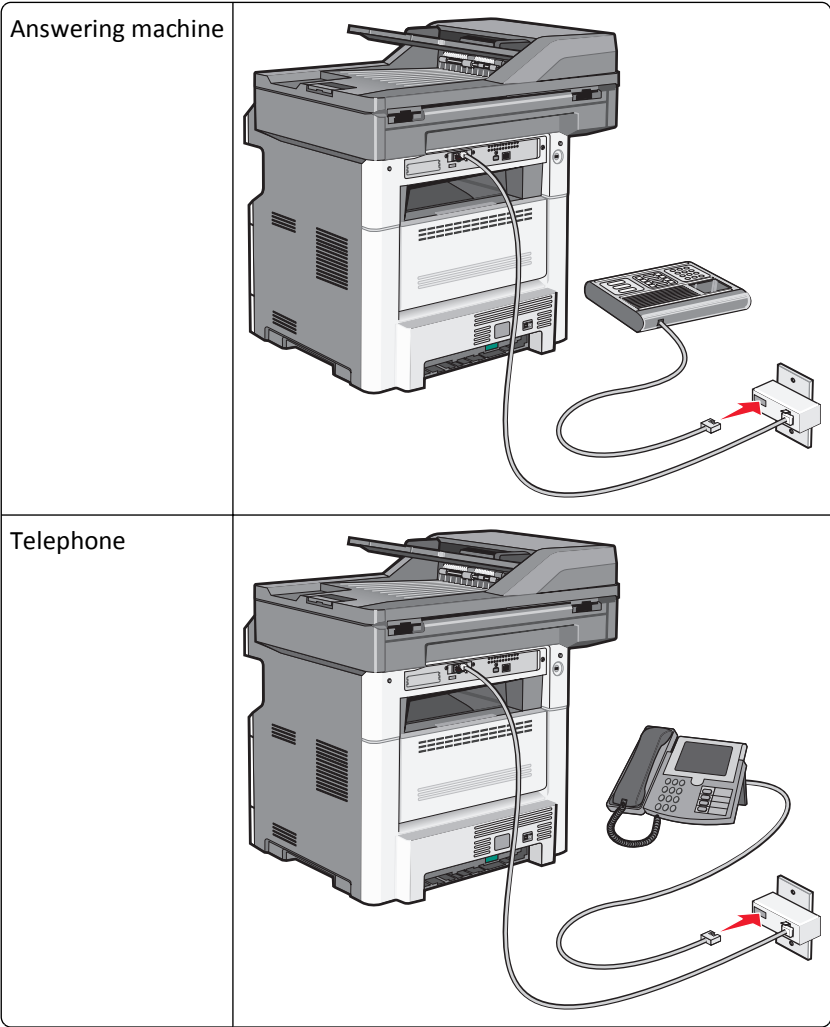

Germany

There is a special RJ-11 plug installed in the printer EXT port . Do not remove this plug. It is necessary for the proper operation of the fax function and of downstream telephones.

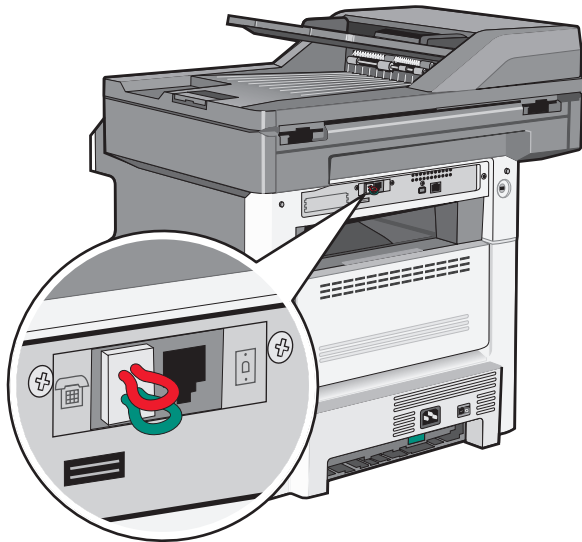

Connecting to a telephone wall jack in Germany

Note: Do not remove the plug. If you remove it, then other telecommunications devices in your home (such as telephones or answering machines) may not work.

- 1 Connect one end of the telephone cable that came with the printer to the printer LINE port .
- 2 Connect the other end of the telephone cable to the adapter.

Note: Your telephone adapter may look different than the one shown. It will fit the wall jack used in your location.

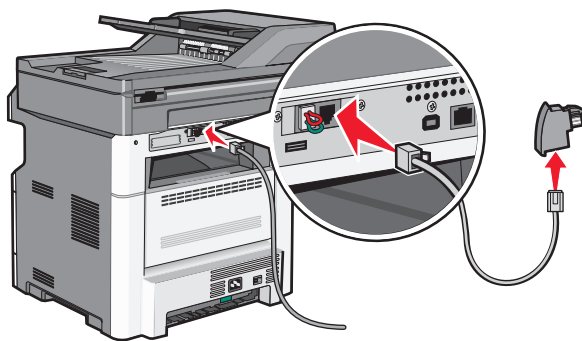

- 3** Connect the adapter into the N slot of an active analog telephone wall jack.

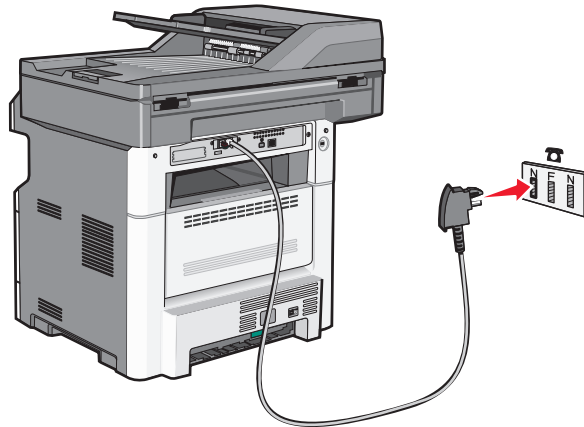

- 4** If you would like to use the same line for both fax and telephone communication, then connect a second telephone line (not provided) between the telephone and the F slot of an active analog telephone wall jack.

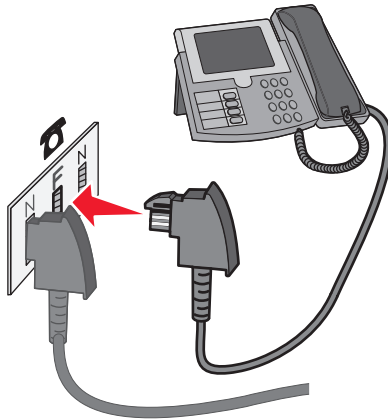

- 5** If you would like to use the same line for recording messages on your answering machine, then connect a second telephone cable between the answering machine and the other N slot of the active analog telephone wall jack.

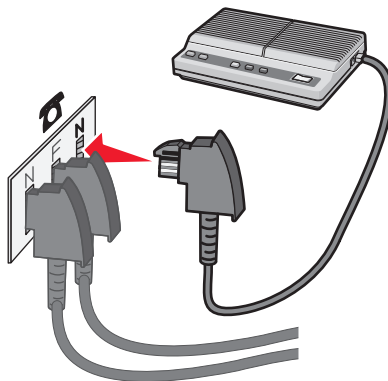

Connecting to a computer with a modem

Connect the printer to a computer with a modem to send faxes from the software program.

Note: Setup steps may vary depending on your country or region.

1 Make sure you have the following:

- A telephone
- A computer with a modem
- Three telephone cords
- A telephone wall jack

2 Connect one end of the telephone cable that came with the printer to the printer LINE port .

3 Connect the other end of the telephone cable to an active analog telephone wall jack.

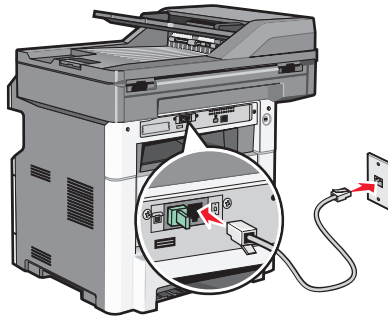

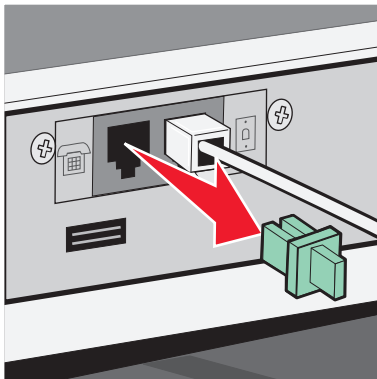

4 Remove the protective plug from the printer EXT port .

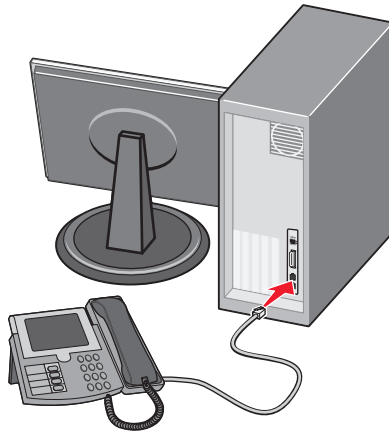

5 Connect your telephone to the computer telephone jack.

Note: See the manual that came with your computer for the telephone connections.



- 6 Connect an additional telephone cord from the computer modem LINE port  to the printer EXT port .

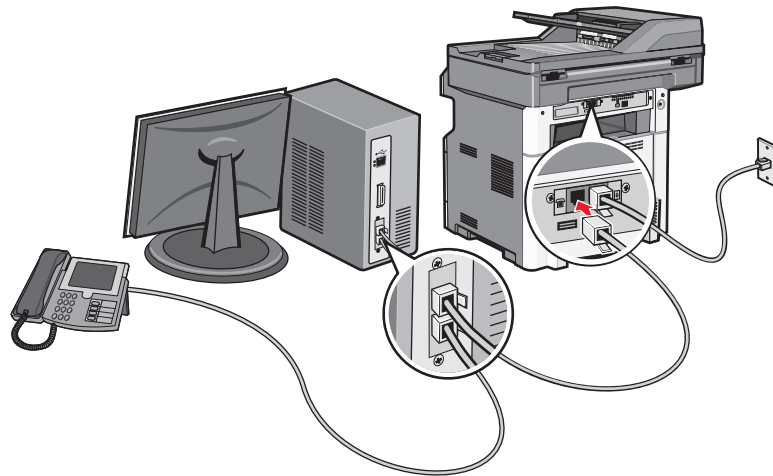

Enabling the fax function

The fax function must be enabled prior to use. If you disabled the fax function when setting up the printer for the first time or if the printer has been off for an extended time, then follow these steps:

Note: Before completing these instructions, make sure the fax cables are connected. For more information, see “Choosing a fax connection” on page 121.

- 1 Touch **Menus**.
- 2 Touch **Settings**.
- 3 Touch **General Settings**.
- 4 Touch the left or right arrow next to **Run initial setup** to select **Yes**.
- 5 Touch **Submit**.
Submitting changes appears.
- 6 Turn off the printer, connect the fax cables, and then turn the printer back on.
- 7 From the printer control panel, select your language.
- 8 Select your country or region, and then touch **Continue**.

- 9 Select your time zone, and then touch **Continue**.
- 10 Touch **Fax**, and then touch **Continue**.
- 11 Select any additional buttons you want to display on the home screen, and then touch **Continue**.
- 12 Enter the Fax Station Name, and then touch **Enter**.
- 13 Enter the Fax Station Number, and then touch **Continue**.
- 14 Touch **Enter**.
- 15 If prompted, set the date and time, and then touch **Continue**.
When the home screen appears, the fax function is enabled.

Using the Embedded Web Server for fax setup

- 1 Type the printer IP address into the address field of your Web browser.
Note: If you do not know the IP address of the printer, then print a network setup page and locate the address in the TCP/IP section.
- 2 Click **Settings**.
- 3 Click **Fax Settings**.
- 4 Click **Analog Fax Setup**.
- 5 Click inside the Station Name box, and then enter the name to be printed on all outgoing faxes.
- 6 Click inside the Station Number box, and then enter the printer fax number.
- 7 Click **Submit**.

Setting the date and time

If the date or time that is printed on a fax job is incorrect, then you can reset the date and time. Then the correct date and time will be printed on every fax job. To set the date and time:

- 1 Type the printer IP address into the address field of your Web browser.
Note: If you do not know the IP address of the printer, then print a network setup page and locate the address in the TCP/IP section.
- 2 Click **Settings**.
- 3 Click **Security**.
- 4 Click **Set Date and Time**.
- 5 In the Network Time Protocol section, select **Enable NTP**.
Note: If you prefer to set the date and time manually, click inside the Manually Set Date & Time box, and then enter the current date and time.
- 6 Verify that the time zone is correct.
- 7 Click **Submit**.

Turning daylight saving time on or off

The printer can be set to automatically adjust for daylight saving time for certain time zones:

- 1 Type the printer IP address into the address field of your Web browser.
Note: If you do not know the IP address of the printer, then print a network setup page and locate the address in the TCP/IP section.
- 2 Click **Settings**.
- 3 Click **Security**.
- 4 Click **Set Date and Time**.
- 5 Select **Automatically Observe DST**.
- 6 Click **Submit**.

Sending a fax

Sending a fax using the printer control panel

- 1 Load an original document faceup, short edge first into the ADF or facedown on the scanner glass.
Note: Do not load postcards, photos, small items, transparencies, photo paper, or thin media (such as magazine clippings) into the ADF. Place these items on the scanner glass.
- 2 If you are loading a document into the ADF, then adjust the paper guides.
- 3 On the home screen, touch **Fax**.
- 4 Enter the fax number or a shortcut using the touch screen or keypad.
To add recipients, touch **Next Number**, and then enter the recipient's telephone number or shortcut number, or search the address book.
Note: To place a dial pause within a fax number, press . The dial pause appears as a comma in the "Fax to" box. Use this feature if you need to dial an outside line first.
- 5 Touch **Fax It**.

Getting ready to send a fax using the computer

For Windows users

- 1 Verify that the PostScript driver is installed.
- 2 Verify that the fax option is installed in the printer driver.
- 3 From the Print dialog Fax screen, type the name and number of the fax recipient.

For Mac OS X version 10.2 and 10.3 users

- 1 With a document open, choose **File > Print**.
- 2 From the print options pop-up menu, choose **Job Routing**.

- 3 Select **Fax**, and then enter the recipient name, number, and other information as needed.
- 4 Click **Print**.

For Mac OS X version 10.4 or later users

- 1 With a document open, choose **File > Print**.
- 2 From the PDF pop-up menu, choose **Fax PDF**.
- 3 Type the fax number in the To field, and enter other information as needed.
- 4 Click **Fax**.

If you receive an error, "No fax modems were found", follow these directions to add your printer as a fax:

- a From the Printer pop-up menu, choose **Add Printer**.
- b Select the printer from the dialog that appears.
- c From the Print Using pop-up menu, choose **Select a driver to use**.
- d From the list, choose your printer fax model, and then click **Add**.

Installing a PostScript driver

A PostScript printer driver is software that lets the computer communicate with the printer. A PostScript driver is needed to send a fax from a computer. This driver may be installed during the initial printer setup. If you need to install the software after setup, follow these instructions:

For Windows users

- 1 Close all open software programs.
- 2 Insert the *Software and Documentation* CD.
Note: If you cannot locate the *Software and Documentation* CD, you can download the driver from the Lexmark Web site at www.lexmark.com. See "Using the World Wide Web" on page 135.
- 3 From the main installation dialog, click **Install Printer and Software**.
- 4 Click **Agree** to accept the licensing agreement.
- 5 From the Drivers and Utilities dialog, select **Custom**, and then click **Next**.
- 6 Choose **Select Components**, and then click **Next**.
- 7 From the "Select your printer from the list" area, choose your printer model with the letters "PS" in the Print Emulation column.
- 8 Click **Add Printer**.
- 9 Click **Finish**, and then follow the instructions on the screen.

Using the World Wide Web

- 1 Go to the Lexmark Web site at www.lexmark.com.
- 2 From the Drivers & Downloads menu, click **Driver Finder**.
- 3 Select your printer, select your operating system, and then select the PostScript driver.
- 4 Download the driver and install the printer software.

- 5 Click **Agree** to accept the licensing agreement.
- 6 From the Drivers and Utilities dialog, select **Custom**, and then click **Next**.
- 7 Choose **Select Components**, and then click **Next**.
- 8 From the “Select your printer from the list” area, choose your printer model with the letters “PS” in the Print Emulation column.
- 9 Click **Add Printer**.
- 10 Click **Finish**, and then follow the instructions on the screen.

Sending a fax using the computer

Faxing from a computer lets you send electronic documents without leaving your desk. This gives you the flexibility of faxing documents directly from software programs.

For Windows users

Notes:

- In order to perform this function from your computer, you must use the PostScript printer driver for your printer.
- Verify that the fax option is installed in the printer driver.

- 1 With a file open, click **File > Print**.
- 2 Click **Properties, Preferences, Options, or Setup**.
- 3 Click the **Other Options** tab, and then click **Fax**.
- 4 On the Fax screen, type the name and number of the fax recipient.
- 5 Click **OK**, and then click **OK** again.
- 6 Click **OK**.

For Mac OS X version 10.2 and 10.3 users

- 1 With a document open, choose **File > Print**.
- 2 From the print options pop-up menu, choose **Job Routing**.
- 3 Select **Fax**, and then enter the recipient name, number, and other information as needed.
- 4 Click **Print**.

For Mac OS X version 10.4 or later users

- 1 With a document open, choose **File > Print**.
- 2 From the PDF pop-up menu, choose **Fax PDF**.
- 3 Type the fax number in the To field, and enter other information as needed.
- 4 Click **Fax**.

If you receive an error, "No fax modems were found", follow these directions to add your printer as a fax:

- a From the Printer pop-up menu, choose **Add Printer**.
- b Select the printer from the dialog that appears.
- c From the Print Using pop-up menu, choose **Select a driver to use**.
- d From the list, choose your printer fax model, and then click **Add**.

Creating shortcuts

Creating a fax destination shortcut using the Embedded Web Server

Instead of entering the entire phone number of a fax recipient on the printer control panel each time you want to send a fax, you can create a permanent fax destination and assign a shortcut number. A shortcut can be created to a single fax number or a group of fax numbers.

- 1 Type the printer IP address into the address field of your Web browser.

Note: If you do not know the IP address of the printer, then print a network setup page and locate the IP address in the TCP/IP section.

- 2 Click **Settings**.

- 3 Click **Manage Shortcuts**.

Note: A password may be required. If you do not have an ID and password, get one from your system support person.

- 4 Click **Fax Shortcut Setup**.

- 5 Type a unique name for the shortcut, and then enter the fax number.

To create a multiple-number shortcut, enter the fax numbers for the group.

Note: Separate each fax number in the group with a semicolon (;).

- 6 Assign a shortcut number.

If you enter a number that is already in use, then you are prompted to select another number.

- 7 Click **Add**.

Creating a fax destination shortcut using the touch screen

- 1 Load an original document faceup, short edge first into the ADF or facedown on the scanner glass.

Note: Do not load postcards, photos, small items, transparencies, photo paper, or thin media (such as magazine clippings) into the ADF. Place these items on the scanner glass.

- 2 If you are loading a document into the ADF, then adjust the paper guides.

- 3 On the home screen, touch **Fax**.

- 4 Enter the fax number.

To create a group of fax numbers, touch **Next number**, and then enter the next fax number.

- 5 Touch **Save as Shortcut**.

- 6 Enter a name for the shortcut.
- 7 Verify that the shortcut name and number are correct, and then touch **OK**. If the name or number is incorrect, then touch **Cancel**, and then reenter the information.
If you enter a number that is already in use, then you are prompted to select another number.
- 8 Touch **Fax It** to send the fax, or touch  to return to the home screen.

Using shortcuts and the address book

Using fax shortcuts

Fax shortcuts are just like the speed dial numbers on a telephone or fax machine. You can assign shortcut numbers when creating permanent fax destinations. Permanent fax destinations or speed dial numbers are created in the Manage Shortcuts link located under Settings on the Embedded Web Server. A shortcut number (1–99999) can contain a single recipient or multiple recipients. By creating a group fax shortcut with a shortcut number, you can quickly and easily fax broadcast information to an entire group.

- 1 Load an original document faceup, short edge first into the ADF or facedown on the scanner glass.
Note: Do not place postcards, photos, small items, transparencies, photo paper, or thin media (such as magazine clippings) into the ADF. Place these items on the scanner glass.
- 2 If you are loading a document into the ADF, then adjust the paper guides.
- 3 Press , and then enter the shortcut number using the keypad.

Using the address book

Note: If the address book feature is not enabled, then contact your system support person.

- 1 Load an original document faceup, short edge first into the ADF or facedown on the scanner glass.
Note: Do not load postcards, photos, small items, transparencies, photo paper, or thin media (such as magazine clippings) into the ADF. Place these items on the scanner glass.
- 2 If you are loading a document into the ADF, then adjust the paper guides.
- 3 On the home screen, touch **Fax**.
- 4 Touch **Search Address Book**.
- 5 Using the virtual keyboard, type the name or part of the name of the person whose fax number you want to find. (Do not attempt to search for multiple names at the same time.)
- 6 Touch **Search**.
- 7 Touch the name to add it to the “Fax to” list.
- 8 Repeat steps 4 through 7 to enter additional addresses.
- 9 Touch **Fax It**.

Customizing fax settings

Changing the fax resolution

Adjusting the resolution setting changes the quality of the fax. Settings range from Standard (fastest speed) to Ultra Fine (slowest speed, best quality).

- 1 Load an original document faceup, short edge first into the ADF or facedown on the scanner glass.
Note: Do not load postcards, photos, small items, transparencies, photo paper, or thin media (such as magazine clippings) into the ADF. Place these items on the scanner glass.
- 2 If you are loading a document into the ADF, then adjust the paper guides.
- 3 On the home screen, touch **Fax**.
- 4 Use the keypad to enter the fax number.
- 5 Touch **Options**.
- 6 From the Resolution area, touch the arrows to change to the resolution you want.
- 7 Touch **Fax It**.

Making a fax lighter or darker

- 1 Load an original document faceup, short edge first into the ADF or facedown on the scanner glass.
Note: Do not load postcards, photos, small items, transparencies, photo paper, or thin media (such as magazine clippings) into the ADF. Place these items on the scanner glass.
- 2 If you are loading a document into the ADF, then adjust the paper guides.
- 3 On the home screen, touch **Fax**.
- 4 Use the keypad to enter the fax number.
- 5 Touch **Options**.
- 6 From the Darkness area, touch the arrows to adjust the darkness of the fax.
- 7 Touch **Fax It**.

Sending a fax at a scheduled time

- 1 Load an original document faceup, short edge first into the ADF or facedown on the scanner glass.
Note: Do not load postcards, photos, small items, transparencies, photo paper, or thin media (such as magazine clippings) into the ADF. Place these items on the scanner glass.
- 2 If you are loading a document into the ADF, then adjust the paper guides.
- 3 On the home screen, touch **Fax**.
- 4 Enter the fax number using the numbers on the touch screen or keypad.
- 5 Touch **Options**.
- 6 Touch **Advanced Options**.

7 Touch **Delayed Send**.

Note: If Fax Mode is set to Fax Server, the Delayed Send button will not appear. Faxes waiting for transmission are listed in the Fax Queue.

8 Touch the arrows to adjust the time the fax will be transmitted.

The time is increased or decreased in increments of 30 minutes. If the current time is shown, the left arrow is unavailable.

9 Touch **Done**.**10** Touch **Fax it**.

Note: The document is scanned and then faxed at the scheduled time.

Printing an incoming fax on both sides of the paper (duplexing)

In order to save paper, you can print all incoming faxes on both sides of the paper.

- 1** On the home screen, touch **Menus**.
- 2** Touch **Settings**, and then touch **Fax Settings**.
- 3** Touch **Analog Fax Setup**.
- 4** Touch **Fax Receive Setting**.
- 5** Touch the arrows until **Sides (Duplex)** appears.
- 6** Touch the arrows until **Yes** appears.
- 7** Touch **Submit**.

Viewing a fax log

- 1** Type the printer IP address into the address field of your Web browser.

Note: If you do not know the IP address of the printer, then print a network setup page and locate the IP address in the TCP/IP section.
- 2** Click **Settings**.
- 3** Click **Reports**.
- 4** Click **Fax Job Log** or **Fax Call Log**.

Blocking junk faxes

- 1** Type the printer IP address into the address field of your Web browser.

Note: If you do not know the IP address of the printer, then print a network setup page and locate the IP address in the TCP/IP section.
- 2** Click **Settings**.
- 3** Click **Fax Settings**.
- 4** Click **Analog Fax Setup**.

5 Click the **Block No Name Fax** option.

This option blocks all incoming faxes that have a private caller ID or no fax station name.

6 In the Banned Fax List field, enter the phone numbers or fax station names of specific fax callers you want to block.

Canceling an outgoing fax

Canceling a fax while the original documents are still scanning

- When using the ADF, touch **Cancel Job** while **Scanning...** appears.
- When using the scanner glass, touch **Cancel Job** while **Scanning...** appears or while **Scan the Next Page / Finish the Job** appears.

Canceling a fax after the original documents have been scanned to memory

1 On the home screen, touch **Cancel Jobs**.

The Cancel Jobs screen appears.

2 Touch the job or jobs you want to cancel.

Only three jobs appear on the screen; touch the down arrow until the job you want appears, and then touch the job you want to cancel.

3 Touch **Delete Selected Jobs**.

The Deleting Selected Jobs screen appears, the selected jobs are deleted, and then the home screen appears.

Understanding fax options

Original Size

This option opens a screen where you can choose the size of the documents you are going to fax.

- Touch a paper size button to select that size as the Original Size setting. The fax screen appears with your new setting displayed.
- When Original Size is set to Mixed Sizes, you can scan an original document that contains mixed paper sizes.

Content

This option tells the printer the original document type. Choose from Text, Text/Photo, or Photograph. Color can be turned on or off with any of the Content choices. Content affects the quality and size of your scan.

- **Text**—Emphasizes sharp, black, high-resolution text against a clean, white background
- **Text/Photo**—Used when the original documents are a mixture of text and graphics or pictures
- **Photograph**—Tells the scanner to pay extra attention to graphics and pictures. This setting increases the time it takes to scan, but emphasizes a reproduction of the full dynamic range of tones in the original document. This increases the amount of information saved.
- **Color**—Sets the scan type and output for the fax. Color documents can be scanned and sent to a fax destination.

Sides (Duplex)

This option informs the printer if the original document is simplex (printed on one side) or duplex (printed on both sides). This lets the scanner know what needs to be scanned for inclusion in the fax.

Resolution

This options increases how closely the scanner examines the document you want to fax. If you are faxing a photo, a drawing with fine lines, or a document with very small text, increase the Resolution setting. This will increase the amount of time required for the scan and will increase the quality of the fax output.

- **Standard**—Suitable for most documents
- **Fine**—Recommended for documents with small print
- **Super fine**—Recommended for original documents with fine detail
- **Ultra fine**—Recommended for documents with pictures or photos

Darkness

This option adjusts how light or dark your faxes will turn out in relation to the original document.

Advanced Options

Touching this button opens a screen where you can change Delayed Send, Advanced Imaging, Custom Job, Transmission Log, Scan Preview, Edge Erase, and Advanced Duplex settings.

- **Delayed Send**—Lets you send a fax at a later time or date. After setting up your fax, touch **Delayed Send**, enter the time and date you would like to send your fax, and then touch **Done**. This setting can be especially useful in sending information to fax lines that are not readily available during certain hours, or when transmission times are cheaper.

Note: If the printer is turned off when the delayed fax is scheduled to be sent, the fax is sent the next time the printer is turned on.

- **Advanced Imaging**—Adjusts Background Removal, Contrast, Scan Edge to Edge, Shadow Detail, and Mirror Image before you fax the document
- **Custom Job (Job Build)**—Combines multiple scanning jobs into a single job
- **Transmission Log**—Prints the transmission log or transmission error log
- **Scan Preview**—Displays the image before it is included in the fax. When the first page is scanned, the scanning is paused, and a preview image appears.
- **Edge Erase**—Eliminates smudges or information around the edges of a document. You can choose to eliminate an equal area around all four sides of the paper, or pick a particular edge. Edge Erase will erase whatever is within the area selected, leaving nothing on that portion of the scan.
- **Advanced Duplex**—Controls how many sides and what orientation an original document has, and whether original documents are bound along the long edge or the short edge

Note: Some Advanced Duplex options may not be available on all printer models.

Improving fax quality

Question	Tip
When should I use Text mode?	<ul style="list-style-type: none"> • Use Text mode when text preservation is the main goal of the fax, and preserving images copied from the original document is not a concern. • Text mode is recommended for faxing receipts, carbon copy forms, and documents that contain only text or fine line art.
When should I use Text/Photo mode?	<ul style="list-style-type: none"> • Use Text/Photo mode when faxing an original document that contains a mixture of text and graphics. • Text/Photo mode is recommended for magazine articles, business graphics, and brochures.
When should I use Photo mode?	Use Photo mode when faxing photos printed on a laser printer or taken from a magazine or newspaper.

Holding and forwarding faxes

Holding faxes

This option lets you hold received faxes from printing until they are released. Held faxes can be released manually or at a scheduled day or time.

- 1 Type the printer IP address into the address field of your Web browser.

Note: If you do not know the IP address of the printer, then print a network setup page and locate the IP address in the TCP/IP section.

- 2 Click **Settings**.

- 3 Click **Fax Settings**.

- 4 Click **Analog Fax Setup**.

- 5 Click **Holding Faxes**.

- 6 Enter a password in the Print Faxes Password box.

- 7 From the Held Fax Mode menu, select one of the following:

- **Off**
- **Always On**
- **Manual**
- **Scheduled**

- 8 If you selected Scheduled, then continue with the following steps. Otherwise, go to step 9.

- a Click **Fax Holding Schedule**.

- b From the Action menu, select **Hold faxes**.

- c From the Time menu, select the time you want the held faxes released.

- d From the Day(s) menu, select the day you want the held faxes released.

- 9 Click **Add**.

Forwarding a fax

This option lets you print and forward received faxes to a fax number, e-mail address, FTP site, or LDSS.

- 1 Type the printer IP address into the address field of your Web browser.

Note: If you do not know the IP address of the printer, then print a network setup page and locate the IP address in the TCP/IP section.

- 2 Click **Settings**.

- 3 Click **Fax Settings**.

- 4 Click **Analog Fax Setup**.

- 5 From the Fax Forwarding menu, select one of the following:

- **Print**
- **Print and Forward**
- **Forward**

- 6 From the "Forward to" menu, select one of the following:

- **Fax**
- **E-mail**
- **FTP**
- **LDSS**
- **eSF**

- 7 Click inside the Forward to Shortcut box, and then enter the shortcut number where you want the fax forwarded.

Note: The shortcut number must be a valid shortcut number for the setting that was selected in the "Forward to" menu.

- 8 Click **Submit**.

Scanning to an FTP address

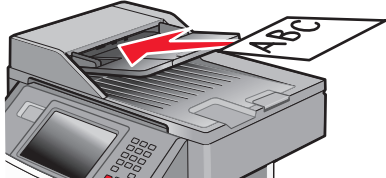
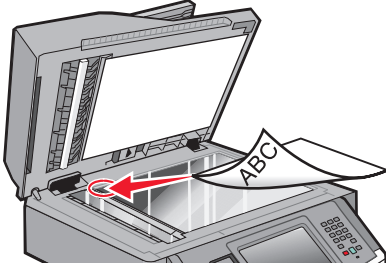
ADF	Scanner glass
 <p>Use the ADF for multiple-page documents.</p>	 <p>Use the scanner glass for single pages, small items (such as postcards or photos), transparencies, photo paper, or thin media (such as magazine clippings).</p>

The scanner lets you scan documents directly to a *File Transfer Protocol (FTP)* server. Only one FTP address may be sent to the server at a time.

Once an FTP destination has been configured by your system support person, the name of the destination becomes available as a shortcut number, or it is listed as a profile under the Held Jobs icon. An FTP destination could also be another PostScript printer; for example, a color document can be scanned and then sent to a color printer. Sending a document to an FTP server is similar to sending a fax. The difference is that you are sending the information over your network instead of over the phone line.

Scanning to an FTP address

Scanning to an FTP address using the keypad

- 1 Load an original document faceup, short edge first into the ADF or facedown on the scanner glass.
 - Note:** Do not load postcards, photos, small items, transparencies, photo paper, or thin media (such as magazine clippings) into the ADF. Place these items on the scanner glass.
- 2 If you are loading a document into the ADF, then adjust the paper guides.
- 3 On the home screen, touch **FTP**.
- 4 Type the FTP address.
- 5 Touch **Send It**.

Scanning to an FTP address using a shortcut number

- 1 Load an original document faceup, short edge first into the ADF or facedown on the scanner glass.
 - Note:** Do not load postcards, photos, small items, transparencies, photo paper, or thin media (such as magazine clippings) into the ADF. Place these items on the scanner glass.
- 2 If you are loading a document into the ADF, then adjust the paper guides.

- 3 Press #, and then enter the FTP shortcut number.
- 4 Touch **Send It**.

Scanning to an FTP address using the address book

- 1 Load an original document faceup, short edge first into the ADF or facedown on the scanner glass.
Note: Do not load postcards, photos, small items, transparencies, photo paper, or thin media (such as magazine clippings) into the ADF. Place these items on the scanner glass.
- 2 If you are loading a document into the ADF, then adjust the paper guides.
- 3 On the home screen, touch **FTP**.
- 4 Touch **Search Address Book**.
- 5 Type the name or part of the name you are searching for, and then touch **Search**.
- 6 Touch the name that you want to add to the To field.
- 7 Touch **Send It**.

Creating shortcuts

Instead of typing the entire FTP site address using the keypad each time you want to send a document to an FTP server, you can create a permanent FTP destination and assign a shortcut number. There are two methods for creating shortcut numbers: using a computer or using the printer touch screen.

Creating an FTP shortcut using the Embedded Web Server

- 1 Type the printer IP address into the address field of your Web browser.
Note: If you do not know the IP address of the printer, then print a network setup page and locate the IP address in the TCP/IP section.
- 2 Click **Settings**.
- 3 Under Other Settings, click **Manage Shortcuts**.
Note: A password may be required. If you do not have an ID and password, get one from your system support person.
- 4 Click **FTP Shortcut Setup**.
- 5 Enter the appropriate information into the boxes.
- 6 Enter a shortcut number.
If you enter a number that is already in use, then you are prompted to select another number.
- 7 Click **Add**.

Creating an FTP shortcut using the touch screen

- 1 On the home screen, touch **FTP**.
- 2 Type the address of the FTP site.
- 3 Touch **Save as Shortcut**.
- 4 Enter a name for the shortcut.
- 5 Verify that the shortcut name and number are correct, and then touch **OK**. If the name or number is incorrect, then touch **Cancel**, and then reenter the information.
If you enter a number that is already in use, then you are prompted to select another number.
- 6 Touch **Send It** to start the scan, or touch  to return to the home screen.

Understanding FTP options

Original Size

This option opens a screen where you can choose the size of the documents you are going to scan.

- Touch a paper size button to select that size as the Original Size setting. The FTP screen appears with your new setting displayed.
- When Original Size is set to Mixed Sizes, you can scan an original document that contains mixed paper sizes.

Sides (Duplex)

This option informs the printer if the original document is simplex (printed on one side) or duplex (printed on both sides). This lets the scanner know what needs to be scanned for inclusion in the document.

Orientation

This option tells the printer whether the original document is in portrait or landscape orientation and then changes the Sides and Binding settings to match the original document orientation.

Binding

Tells the printer whether the original document is bound on the long-edge or short-edge side.

Resolution

This option adjusts the output quality of your file. Increasing the image resolution increases the file size and the time needed to scan your original document. Image resolution can be decreased to reduce the file size.

Send As

This option sets the output (PDF, TIFF, JPEG, or XPS) for the scanned image.

- **PDF**—Creates a single file with multiple pages, viewable with Adobe Reader. Adobe Reader is provided free by Adobe at www.adobe.com.
- **Secure PDF**—Creates an encrypted PDF file that protects the file contents from unauthorized access
- **TIFF**—Creates multiple files or a single file. If Multi-page TIFF is turned off in the Settings menu of the Embedded Web Server, then TIFF saves one page in each file. The file size is usually larger than an equivalent JPEG.
- **JPEG**—Creates and attaches a separate file for each page of your original document, viewable by most Web browsers and graphics programs
- **XPS**—Creates a single XPS file with multiple pages, viewable using an Internet Explorer-hosted viewer and the .NET Framework, or by downloading a third party standalone viewer

Content

This option tells the printer the original document type. Choose from Text, Text/Photo, or Photo. Color can be turned on or off with any of the Content choices. Content affects the quality and size of your FTP file.

- **Text**—Emphasize sharp, black, high-resolution text against a clean, white background
- **Text/Photo**—Used when the original documents are a mixture of text and graphics or pictures
- **Photograph**—Tells the scanner to pay extra attention to graphics and pictures. This setting increases the time it takes to scan, but emphasizes a reproduction of the full dynamic range of tones in the original document. This increases the amount of information saved.
- **Color**—Sets the scan type and output for the FTP file. Color documents can be scanned and sent to an FTP site, computer, e-mail address, or the printer.

Advanced Options

Touching this button opens a screen where you can change Advanced Imaging, Custom Job, Transmission Log, Scan Preview, Edge Erase, and Darkness settings.

- **Advanced Imaging**—Adjusts image output settings before you scan the document
 - **Background Removal**—Adjusts the white portion of the output. Click the arrow buttons to increase or decrease the white portion.
 - **Color Dropout**—Color dropout is used for form Optical Character Recognition (OCR) processing. Selecting a color eliminates the color from a form, enabling improved OCR capabilities.
 - **Contrast**—Click the arrow buttons to increase or decrease the contrast.
 - **JPEG Quality**—Click the arrow buttons to increase or decrease the image compression.
 - **Mirror Image**—Select this box to create a mirror image scan.
 - **Negative Image**—Select this box to create a negative image scan.
 - **Shadow Detail**—Click the arrow buttons to increase or decrease the visible detail in the shadows.
 - **Scan edge to edge**—Select this box to scan edge to edge.
 - **Sharpness**—Click the arrow buttons to increase or decrease the sharpness.
- **Custom Job (Job Build)**—Combines multiple scanning jobs into a single job
- **Transmission Log**—Prints the transmission log or transmission error log

- **Scan Preview**—Displays the first page of an image before it is included in the FTP file. When the first page is scanned, the scanning is paused and a preview image appears.
- **Edge Erase**—Eliminates smudges or information around the edges of a document. You can choose to eliminate an equal area around all four sides of the paper, or pick a particular edge. Edge Erase will erase whatever is within the area selected, leaving nothing on that portion of the scan.
- **Darkness**—Adjusts how light or dark your scanned documents will turn out

Improving FTP quality

Question	Tip
When should I use Text mode?	<ul style="list-style-type: none">• Use Text mode when text preservation is the main goal of sending a document to an FTP site, and preserving images copied from the original document is not a concern.• Text mode is recommended for receipts, carbon copy forms, and documents that only contain text or fine line art.
When should I use Text/Photo mode?	<ul style="list-style-type: none">• Use Text/Photo mode when sending a document to an FTP site that contains a mixture of text and graphics.• Text/Photo mode is recommended for magazine articles, business graphics, and brochures.
When should I use Photo mode?	Use Photo mode when the original document is composed mostly of photos printed on a laser printer or taken from a magazine or newspaper.

Scanning to a computer or flash drive

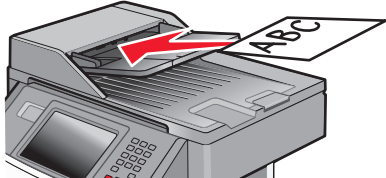
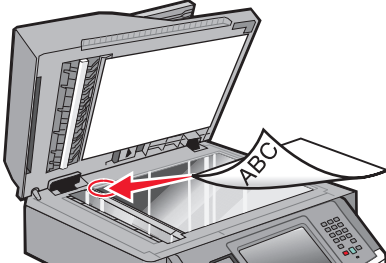
ADF	Scanner glass
	
Use the ADF for multiple-page documents.	Use the scanner glass for single pages, small items (such as postcards or photos), transparencies, photo paper, or thin media (such as magazine clippings).

Scanning to a computer

- 1 Type the printer IP address into the address field of your Web browser.

Note: If you do not know the IP address of the printer, then print a network setup page and locate the IP address in the TCP/IP section.

- 2 Click **Scan Profile**.

Note: In order to use the Scan Profile function, you must have Java installed on your computer.

- 3 Click **Create Scan Profile**.

- 4 Select your scan settings, and then click **Next**.

- 5 Select a location on your computer where you want to save the scanned output file.

- 6 Enter a scan name.

The scan name is the name that appears in the Scan Profile list on the display.

- 7 Click **Submit**.

- 8 Review the instructions on the Scan Profile screen.

A shortcut number was automatically assigned when you clicked Submit. You can use this shortcut number when you are ready to scan your documents.

- a Load an original document faceup, short edge first into the ADF or facedown on the scanner glass.

Note: Do not load postcards, photos, small items, transparencies, photo paper, or thin media (such as magazine clippings) into the ADF. Place these items on the scanner glass.

- b If you are loading a document into the ADF, then adjust the paper guides.

- c Press **#**, and then enter the shortcut number using the keypad, or touch **Held Jobs** on the home screen, and then touch **Profiles**.
- d After you enter the shortcut number, the scanner scans and sends the document to the directory or program you specified. If you touched **Profiles** on the home screen, then locate your shortcut on the list.

9 Return to the computer to view the file.

The output file is saved in the location you specified or launched in the program you specified.

Understanding scan profile options

Quick Setup

This option lets you select preset formats or customize the scan job settings. You can select one of these settings:

Custom	Photo - Color JPEG
Text - BW PDF	Photo - Color TIFF
Text - BW TIFF	Text/Photo - BW PDF Text/Photo - Color PDF

To customize the scan job settings, from the Quick Setup menu, select **Custom**. Then change the scan settings as needed.

Format Type

This option sets the output (PDF, JPEG, TIFF, SECURE PDF, or XPS) for the scanned image.

- **PDF**—Creates a single file with multiple pages, viewable with Adobe Reader. Adobe Reader is provided free by Adobe at www.adobe.com.
- **JPEG**—Creates and attaches a separate file for each page of your original document, viewable by most Web browsers and graphics programs
- **TIFF**—Creates multiple files or a single file. If Multi-page TIFF is turned off in the Settings menu of the Embedded Web Server, then TIFF saves one page in each file. The file size is usually larger than an equivalent JPEG.
- **Secure PDF**—Creates an encrypted PDF file that protects the file contents from unauthorized access
- **XPS**—Creates a single XPS file with multiple pages, viewable using an Internet Explorer-hosted viewer and the .NET Framework, or by downloading a third party standalone viewer

Compression

This option sets the format used to compress the scanned output file.

Default Content

This option tells the printer the original document type. Choose from Text, Text/Photo, or Photo. Default Content affects the quality and size of your scanned file.

Text—Emphasizes sharp, black, high-resolution text against a clean, white background

Text/Photo—Used when the original documents are a mixture of text and graphics or pictures

Photo—Tells the scanner to pay extra attention to graphics and pictures. This setting increases the time it takes to scan, but emphasizes a reproduction of the full dynamic range of tones in the original document. This increases the amount of information saved.

Color

This option tells the printer the color of the original documents. You can select Gray, BW (Black and White), or Color.

Original Size

This option sets the size of the documents you are going to scan. When Original Size is set to Mixed Sizes, you can scan an original document that contains mixed paper sizes (letter- and legal-size pages).

Orientation

This option tells the printer whether the original document is in portrait or landscape orientation and then changes the Sides and Binding settings to match the original document orientation.

Duplex

This option informs the printer if your original document is printed on a single side or duplex (printed on both sides). This lets the scanner know what needs to be scanned for inclusion in the document.

Note: Duplex scanning is not available on selected printer models.

JPEG Quality

This option adjusts the degree of compression for scanned JPEG documents in relation to the original document.

Darkness

This option adjusts how light or dark your scanned documents will turn out in relation to the original document.

Resolution

This option adjusts the output quality of your file. Increasing the image resolution increases the file size and the time needed to scan your original document. Image resolution can be decreased to reduce the file size.

Advanced Imaging

This option lets you adjust Background Removal, Contrast, Shadow Detail, Sharpness, and Color Dropout before you scan the document. It also lets you Scan edge to edge, as a Mirror Image, or as a Negative Image.

- **Background Removal**—Adjusts the white portion of the output. Click the arrow buttons to increase or decrease the white portion.
- **Contrast**—Click the arrow buttons to increase or decrease the contrast.
- **Shadow Detail**—Click the arrow buttons to increase or decrease the visible detail in the shadows.
- **Sharpness**—Click the arrow buttons to increase or decrease the sharpness.

- **Color Dropout**—Color dropout is used for form Optical Character Recognition (OCR) processing. Selecting a color eliminates the color from a form, enabling improved OCR capabilities.
- **Color Dropout Threshold**—Click the arrow buttons to increase or decrease the amount of color dropout.
- **Scan edge to edge**—Select this check box to scan edge to edge.
- **Mirror Image**—Select this check box to create a mirror image scan.
- **Negative Image**—Select this check box to create a negative image scan.

Scanning to a flash drive

- 1 Load an original document faceup, short edge first into the ADF or facedown on the scanner glass.
Note: Do not load postcards, photos, small items, transparencies, photo paper, or thin media (such as magazine clippings) into the ADF. Place these items on the scanner glass.
- 2 If you are loading a document into the ADF, then adjust the paper guides.
- 3 Insert the flash drive into the USB port on the front of the printer.
The Held Jobs screen appears.
- 4 Touch **Scan to USB drive**.
- 5 Select the scan settings.
- 6 Touch **Scan It**.

Note: While the flash drive is attached to the printer, a USB icon appears on the home screen.

Improving scan quality

Question	Tip
When should I use Text mode?	<ul style="list-style-type: none"> • Use Text mode when text preservation is the main goal of the scan, and preserving images copied from the original document is not a concern. • Text mode is recommended for receipts, carbon copy forms, and documents that only contain text or fine line art.
When should I use Text/Photo mode?	<ul style="list-style-type: none"> • Use Text/Photo mode when scanning an original document that contains a mixture of text and graphics. • Text/Photo mode is recommended for magazine articles, business graphics, and brochures.
When should I use Photo mode?	Use Photo mode when scanning photos printed on a laser printer or taken from a magazine or newspaper.

Understanding printer menus

Menus list

A number of menus are available to make it easy for you to change printer settings. To access the menus, touch  on the home screen.

Paper Menu

Default Source
Paper Size/Type
Configure MP
Substitute Size
Paper Texture
Paper Weight
Paper Loading
Custom Types
Custom Names
Custom Scan Sizes
Universal Setup

Reports

Menu Settings Page
Device Statistics
Network Setup Page
Network <x> Setup Page
Wireless Setup Page¹
Shortcut List
Fax Job Log
Fax Call Log
Copy Shortcuts
E-mail Shortcuts
Fax Shortcuts
FTP Shortcuts
Profiles List
NetWare Setup Page
Print Fonts
Print Directory
Asset Report

Network/Ports

Active NIC
Standard Network²
SMTP Setup
Standard USB
Parallel <x>
Serial <x>

¹ Only appears if a wireless card is installed.

² Depending on the printer setup, this menu item appears as Standard Network or Network <x>.

Security

Edit Security Setups
Miscellaneous Security Settings
Confidential Print
Disc Wiping
Security Audit Log
Set Date and Time

Settings

General Settings
Copy Settings
Fax Settings
E-mail Settings
FTP Settings
Flash Drive Menu
Print Settings

Help

Print all guides
Copy guide
E-mail guide
Fax guide
FTP guide
Information guide
Print Defects guide
Supplies Guide

Paper menu

Default Source menu

Menu item	Description
Default Source Tray <x> MP Feeder Envelope Feeder Manual Paper Manual Env	Sets a default paper source for all print jobs Notes: <ul style="list-style-type: none"> • Tray 1 (standard tray) is the factory default setting. • Only an installed paper source will appear as a menu setting. • A paper source selected by a print job will override the Default Source setting for the duration of the print job. • If the same size and type of paper are in two trays and the Paper Size and Paper Type settings match, then the trays are automatically linked. When one tray is empty, the job prints using the linked tray. • From the Paper menu, Configure MP must be set to Cassette in order for MP Feeder to appear as a menu setting.

Paper Size/Type menu

Menu item	Description
Tray <x> Size A4 A5 A6 JIS B5 Legal Letter Executive Oficio (México) Folio Statement Universal	Specifies the paper size loaded in each tray Notes: <ul style="list-style-type: none"> • Letter is the US factory default setting. A4 is the international factory default setting. • For trays with automatic size sensing, only the size detected by the hardware appears. • If the same size and type of paper are in two trays and the Paper Size and Paper Type settings match, then the trays are automatically linked. When one tray is empty, the job prints using the linked tray.
Note: Only installed trays are listed in this menu.	

Menu item	Description
<p>Tray <x> Type</p> <ul style="list-style-type: none"> Plain Paper Card Stock Transparency Glossy Heavy Glossy Labels Bond Letterhead Preprinted Colored Paper Light Paper Heavy Paper Rough Paper Recycled Custom Type <x> 	<p>Specifies the type of paper loaded in each tray</p> <p>Notes:</p> <ul style="list-style-type: none"> • Plain Paper is the factory default setting for Tray 1. Custom Type <x> is the factory default setting for all other trays. • If available, a user-defined name will appear instead of Custom Type <x>. • Use this menu item to configure automatic tray linking.
<p>Multipurpose Tray Size</p> <ul style="list-style-type: none"> A4 A5 A6 Executive Oficio (México) Folio JIS B5 Legal Letter Statement Universal 7 3/4 Envelope 9 Envelope 10 Envelope DL Envelope C5 Envelope B5 Envelope Other Envelope 	<p>Specifies the paper size loaded in the multipurpose tray</p> <p>Notes:</p> <ul style="list-style-type: none"> • From the Paper menu, Configure Multipurpose Tray must be set to Cassette for Multipurpose Tray to appear as a menu setting. • Letter is the US factory default setting. A4 is the international factory default setting.
<p>Note: Only installed trays are listed in this menu.</p>	

Menu item	Description
<p>Multipurpose Tray Type</p> <ul style="list-style-type: none"> Plain Paper Card Stock Transparency Glossy Heavy Glossy Labels Bond Envelope Rough Envelope Letterhead Preprinted Colored Paper Light Paper Heavy Paper Rough Paper Recycled Custom Type <x> 	<p>Specifies the type of paper loaded in the multipurpose tray</p> <p>Notes:</p> <ul style="list-style-type: none"> • From the Paper menu, Configure Multipurpose Tray must be set to Cassette for Multipurpose Tray to appear as a menu setting. • Plain paper is the factory default setting.
<p>Manual Paper Size</p> <ul style="list-style-type: none"> A4 A5 JIS B5 Letter Legal Executive Folio Statement Universal 	<p>Specifies the size of the paper being manually loaded</p> <p>Note: Letter is the US factory default setting. A4 is the international factory default setting.</p>
<p>Manual Paper Type</p> <ul style="list-style-type: none"> Paper Card Stock Transparencies Glossy paper Heavy Glossy Labels Light Paper Heavy Paper Rough Paper 	<p>Specifies the type of paper being manually loaded</p> <p>Note: Plain paper is the factory default setting.</p>
<p>Note: Only installed trays are listed in this menu.</p>	

Menu item	Description
Manual Envelope Size 7 3/4 Envelope 9 Envelope 10 Envelope C5 Envelope B5 Envelope DL Envelope Other Envelope	Specifies the size of the envelope being manually loaded Note: 10 Envelope is the US factory default setting. DL Envelope is the international factory default setting.
Manual Envelope Type Envelope Rough Envelope Custom Type <x>	Specifies the type of envelope being manually loaded Note: Envelope is the factory default setting.
Note: Only installed trays are listed in this menu.	

Configure MP menu

Menu item	Description
Configure MP Cassette Manual First	Determines when the printer selects paper from the multipurpose feeder Notes: <ul style="list-style-type: none"> • Cassette is the factory default setting. • The Cassette setting configures the multipurpose feeder as an automatic paper source. • When Manual is selected, the multipurpose feeder can be used only for manual feed print jobs. • If paper is loaded in the multipurpose feeder and First is selected, then paper always feeds from the multipurpose feeder first.

Substitute Size menu

Menu item	Description
Substitute Size Off Statement/A5 Letter/A4 All Listed	Substitutes a specified paper size if the requested paper size is not available Notes: <ul style="list-style-type: none"> • All Listed is the factory default setting. All available substitutions are allowed. • The Off setting indicates no size substitutions are allowed. • Setting a substitution lets the job print without a Change Paper message appearing.

Paper Texture menu

In the Paper Texture menu, the Select Type and Select Texture features work together to enable you to select the texture for a specific type of paper.

Menu item	Description
<p>Select Type</p> <ul style="list-style-type: none"> Plain Texture Card Stock Texture Transparency Texture Recycled Texture Labels Texture Bond Texture Envelope Texture Rough Envelope Texture Letterhead Texture Preprinted Texture Colored Texture Light Texture Heavy Texture Rough/Cotton Texture Custom <x> Texture 	<p>Specifies the paper type</p>
<p>Select Texture</p> <ul style="list-style-type: none"> Smooth Normal Rough 	<p>After you select a setting for Select Type, the Select Texture feature lets you set the texture for that type of media.</p> <p>Notes:</p> <ul style="list-style-type: none"> • Normal is the factory default setting for most items. • Rough is the factory default setting for Bond. • When Rough Texture is the setting selected for Select Type, Rough is the only Select Texture setting available. • Settings appear only if the paper is supported.

Paper Weight menu

In the Paper Weight menu, the Select Type and Select Weight features work together to enable you to select the weight for a specific type of paper.

Menu item	Description
Select Type Plain Weight Card Stock Weight Transparency Weight Recycled Weight Labels Weight Bond Weight Envelope Weight Rough Envelope Weight Letterhead Weight Preprinted Weight Colored Weight Light Weight Heavy Weight Rough/Cotton Weight Custom <x> Texture	Specifies the paper type
Select Weight Light Normal Heavy	After you select a setting for Select Type, the Select Weight feature lets you set the weight for that type of media. Notes: <ul style="list-style-type: none"> • Normal is the factory default setting for most items. • When Light Weight is the setting selected for Select Type, Light is the only Select Weight setting available. • When Heavy Weight is the setting selected for Select Type, Heavy is the only Select Weight setting available. • Settings appear only if the paper is supported.

Paper Loading menu

Menu item	Description
Card Stock Loading Duplex Off	Determines whether 2-sided printing occurs for all jobs that specify Card Stock as the paper type Note: Off is the factory default setting.
Notes: <ul style="list-style-type: none"> • Duplex sets the printer default to 2-sided printing for every print job unless 1-sided printing is selected from Print Properties in Windows or the Print dialog in Macintosh. • If Duplex is selected, all print jobs are sent through the duplex unit, including 1-sided jobs. 	

Menu item	Description
Recycled Loading Duplex Off	Determines whether 2-sided printing occurs for all jobs that specify Recycled as the paper type Note: Off is the factory default setting.
Labels Loading Duplex Off	Determines whether 2-sided printing occurs for all jobs that specify Labels as the paper type Notes: <ul style="list-style-type: none"> • Off is the factory default setting. • Single-sided paper labels designed for laser printers are supported for occasional use: no more than 20 pages a month. Vinyl, pharmacy, and dual-web labels are not supported.
Bond Loading Duplex Off	Determines whether 2-sided printing occurs for all jobs that specify Bond as the paper type Note: Off is the factory default setting.
Letterhead Loading Duplex Off	Determines whether 2-sided printing occurs for all jobs that specify Letterhead as the paper type Note: Off is the factory default setting.
Preprinted Loading Duplex Off	Determines whether 2-sided printing occurs for all jobs that specify Preprinted as the paper type Note: Off is the factory default setting.
Colored Loading Duplex Off	Determines whether 2-sided printing occurs for all jobs that specify Colored as the paper type Note: Off is the factory default setting.
Light Loading Duplex Off	Determines whether 2-sided printing occurs for all jobs that specify Light as the paper type Note: Off is the factory default setting.
Heavy Loading Duplex Off	Determines whether 2-sided printing occurs for all jobs that specify Heavy as the paper type Note: Off is the factory default setting.
Rough Loading Duplex Off	Determines whether 2-sided printing occurs for all jobs that specify Rough as the paper type Note: Off is the factory default setting.
Custom <x> Loading Duplex Off	Determines whether 2-sided printing occurs for all jobs that specify Custom <x> as the paper type Notes: <ul style="list-style-type: none"> • Off is the factory default setting. • Custom <x> Loading is available only if the custom type is supported.
Notes: <ul style="list-style-type: none"> • Duplex sets the printer default to 2-sided printing for every print job unless 1-sided printing is selected from Print Properties in Windows or the Print dialog in Macintosh. • If Duplex is selected, all print jobs are sent through the duplex unit, including 1-sided jobs. 	

Custom Types menu

Menu item	Description
Custom Type <x> Paper Card Stock Transparency Labels Envelope Rough/Cotton	Associates a paper or specialty media type with a factory default Custom Type <x> name or a user-defined Custom Name created from the Embedded Web Server or MarkVision™ Professional. This user-defined name displays instead of Custom Type <x> . Notes: <ul style="list-style-type: none"> • Paper is the factory default setting for the Custom Type. • The custom media type must be supported by the selected tray or feeder in order for you to print from that source.
Recycled Paper Card Stock Transparency Labels Envelope Cotton	Specifies a paper type when the Recycled setting is selected in other menus Notes: <ul style="list-style-type: none"> • Paper is the factory default setting. • The Recycled type must be supported by the selected tray or feeder in order for you to print from that source.

Custom Names menu

Menu item	Definition
Custom Name <x> <none>	Specify a custom name for a paper type. This name replaces a Custom Type <x> name in the printer menus.

Custom Scan Sizes menu

Menu item	Description
ID Card Width 1–14 inches (25–355.6 mm) Height 1–14 inches (25–355.6 mm) Orientation Landscape Portrait 2 scans per side Off On	Specifies a non-standard scan size Notes: <ul style="list-style-type: none"> • 4.65 inches is the US factory default setting for Width. 118 millimeters is the international factory default setting for Width. • 6.06 inches is the US factory default setting for Height. 154 millimeters is the international factory default setting for Height. • Landscape is the factory default setting for Orientation. • On is the factory default setting for 2 scans per side.

Menu item	Description
Custom Scan Size <x> Scan Size Name Width 1–14 inches (25–355.6 mm) Height 1–14 inches (25–355.6 mm) Orientation Landscape Portrait 2 scans per side Off On	Specifies a custom scan size name and options. This name replaces a Custom Scan Size <x> name in the printer menus. Notes: <ul style="list-style-type: none"> • 8.5 inches is the US factory default setting for Width. 216 millimeters is the international factory default setting for Width. • 14 inches is the US factory default setting for Height. 356 millimeters is the international factory default setting for Height. • Landscape is the factory default setting for Orientation. • Off is the factory default setting for 2 scans per side.

Universal Setup menu

These menu items are used to specify the height, width, and feed direction of the Universal Paper Size. The Universal Paper Size is a user-defined paper size setting. It is listed with the other paper size settings and includes similar options, such as support for duplex printing and printing multiple pages on one sheet.

Menu item	Description
Units of Measure Inches Millimeters	Identifies the units of measure Notes: <ul style="list-style-type: none"> • Inches is the US factory default setting. • Millimeters is the international factory default setting.
Portrait Width 3–14 inches 76–360 mm	Sets the portrait width Notes: <ul style="list-style-type: none"> • If the width exceeds the maximum, the printer uses the maximum width allowed. • 8.5 inches is the US factory default setting. Inches can be increased in 0.01-inch increments. • 216 mm is the international factory default setting. Millimeters can be increased in 1-mm increments.
Portrait Height 3–14 inches 76–360 mm	Sets the portrait height Notes: <ul style="list-style-type: none"> • If the height exceeds the maximum, the printer uses the maximum height allowed. • 14 inches is the US factory default setting. Inches can be increased in 0.01-inch increments. • 356 mm is the international factory default setting. Millimeters can be increased in 1-mm increments.

Menu item	Description
Feed Direction Short Edge Long Edge	Specifies the feed direction if the paper can be loaded in either direction Notes: <ul style="list-style-type: none"> • Short Edge is the factory default setting. • Long Edge appears only if the longest edge is shorter than the maximum width supported in the tray.

Reports menu

Note: When you select a menu item from the Reports menu, the indicated report prints.

Menu item	Description
Menu Settings Page	Prints a report containing information about paper loaded into trays, installed memory, the total page count, alarms, timeouts, the printer control panel language, the TCP/IP address, the status of supplies, the status of the network connection, and other information
Device Statistics	Prints a report containing printer statistics such as supply information and details about printed pages
Network Setup Page	Prints a report containing information about the network printer settings, such as the TCP/IP address information Note: This menu item appears only for network printers or printers connected to print servers.
Network <x> Setup Page	Prints a report containing information about the network printer settings, such as the TCP/IP address information Notes: <ul style="list-style-type: none"> • This menu item is available when more than one network option is installed. • This menu item appears only for network printers or printers connected to print servers.
Shortcut List	Prints a report containing information about configured shortcuts
Fax Job Log	Prints a report containing information about the last 200 completed faxes
Fax Call Log	Prints a report containing information about the last 100 attempted, received, and blocked calls
Copy Shortcuts	Prints a report containing information about copy shortcuts
E-mail Shortcuts	Prints a report containing information about e-mail shortcuts
Fax Shortcuts	Prints a report containing information about fax shortcuts
FTP Shortcuts	Prints a report containing information about FTP shortcuts
Profiles List	Prints a list of profiles stored in the printer

Menu item	Description
NetWare Setup Page	Prints a report containing NetWare-specific information about the network settings Note: This menu item appears only for printers with an internal print server installed.
Print Fonts	Prints a report of all the fonts available for the printer language currently set in the printer
Print Directory	Prints a list of all the resources stored on an optional flash memory card or printer hard disk Notes: <ul style="list-style-type: none"> • Job Buffer Size must be set to 100%. • The optional flash memory or printer hard disk must be installed correctly and working properly.
Asset Report	Prints a report containing asset information including the printer serial number and model name. The report contains text and UPC barcodes that can be scanned into an asset database.

Network/Ports menu

Active NIC menu

Menu item	Description
Active NIC Auto <list of available network cards>	Notes: <ul style="list-style-type: none"> • Auto is the factory default setting. • This menu item appears only if an optional network card is installed.

Standard Network or Network <x> menus

Note: Only active ports appear in this menu; all inactive ports are omitted.

Menu item	Description
PCL SmartSwitch On Off	Sets the printer to automatically switch to PCL emulation when a print job requires it, regardless of the default printer language Notes: <ul style="list-style-type: none"> • On is the factory default setting. • When the Off setting is used, the printer does not examine incoming data. • When the Off setting is used, the printer uses PostScript emulation if PS SmartSwitch is set to On. It uses the default printer language specified in the Setup menu if PS SmartSwitch is set to Off.

Menu item	Description
PS SmartSwitch On Off	Sets the printer to automatically switch to PS emulation when a print job requires it, regardless of the default printer language Notes: <ul style="list-style-type: none"> • On is the factory default setting. • When the Off setting is used, the printer does not examine incoming data. • When the Off setting is used, the printer uses PCL emulation if PCL SmartSwitch is set to On. It uses the default printer language specified in the Setup menu if PCL SmartSwitch is set to Off.
NPA Mode Off Auto	Sets the printer to perform the special processing required for bidirectional communication following the conventions defined by the NPA protocol Notes: <ul style="list-style-type: none"> • Auto is the factory default setting. • Changing this setting from the printer control panel and then exiting the menus causes the printer to restart. The menu selection is updated.
Network Buffer Auto 3K to <maximum size allowed>	Sets the size of the network input buffer Notes: <ul style="list-style-type: none"> • Auto is the factory default setting. • The value can be changed in 1-K increments. • The maximum size allowed depends on the amount of memory in the printer, the size of the other link buffers, and whether Resource Save is set to On or Off. • To increase the maximum size range for the Network Buffer, disable or reduce the size of the parallel, serial, and USB buffers. • Changing this setting from the printer control panel and then exiting the menus causes the printer to restart. The menu selection is updated.
Job Buffering Off On Auto	Temporarily stores jobs on the printer hard disk before printing. This menu only appears if a formatted disk is installed. Notes: <ul style="list-style-type: none"> • Off is the factory default setting. • The On value buffers jobs on the printer hard disk. This menu selection appears only when a formatted disk is installed and is not defective. • The Auto setting buffers print jobs only if the printer is busy processing data from another input port. • Changing this setting from the printer control panel and then exiting the menus causes the printer to restart. The menu selection is updated.
Mac Binary PS On Off Auto	Sets the printer to process Macintosh binary PostScript print jobs Notes: <ul style="list-style-type: none"> • Auto is the factory default setting. • The Off setting filters print jobs using the standard protocol. • The On setting processes raw binary PostScript print jobs.

Menu item	Description
Std Network Setup Reports or Network Reports Network Card TCP/IP IPv6 AppleTalk NetWare LexLink	For descriptions and settings of the network setup menus, see the following: <ul style="list-style-type: none"> • “Network Reports menu” on page 168 • “Network Card menu” on page 168 • “TCP/IP menu” on page 169 • “IPv6 menu” on page 170 • “Wireless menu” on page 171 • “AppleTalk menu” on page 171 • “NetWare menu” on page 171 • “LexLink menu” on page 172 Note: The Wireless menu appears only when the printer is connected to a wireless network.
Net <x> Setup Reports or Network Reports Network Card TCP/IP IPv6 Wireless AppleTalk NetWare LexLink	

SMTP Setup menu

Use the following menu to configure the SMTP server.

Menu item	Description
Primary SMTP Gateway Primary SMTP Gateway Port Secondary SMTP Gateway Secondary SMTP Gateway Port	Specifies SMTP server port information Note: 25 is the default SMTP gateway port.
SMTP Timeout 5–30	Specifies the amount of time in seconds before the server stops trying to send the e-mail Note: 30 seconds is the factory default setting.
Reply Address Use SSL Disabled Negotiate Required	Specifies server information. This is a required item. Notes: <ul style="list-style-type: none"> • The message box has a limitation of 512 characters. • Disabled is the factory default setting for Use SSL.
SMTP Server Authentication No authentication required Login / Plain CRAM-MD5 Digest-MD5 NTLM Kerberos 5	Specifies the type of user authentication required for scan to e-mail privileges Note: “No authentication required” is the factory default setting.

Menu item	Description
Device-Initiated E-mail None Use Device SMTP Credentials User-Initiated E-mail None Use Device SMTP Credentials Use Session User ID and Password Use Session E-mail address and Password Prompt User Device Userid Device password Kerberos 5 Realm NTLM Domain	Specifies server information Notes: <ul style="list-style-type: none"> The message boxes have a limitation of 512 characters. None is the factory default setting for Device-Initiated E-mail and User-Initiated E-mail.

Network Reports menu

This menu is available from the Network/Ports menu:

Network/Ports > Standard Network or Network <x> > Std Network Setup or Net <x> Setup > Reports or Network Reports

Menu item	Description
Print Setup Page Print NetWare Setup Page	Prints a report containing information about the current network setup Notes: <ul style="list-style-type: none"> The Setup Page contains information about the network printer settings, such as the TCP/IP address. The NetWare Setup Page menu item appears only on models that support NetWare and shows information about NetWare settings.

Network Card menu

This menu is available from the Network/Ports menu:

Network/Ports > Standard Network or Network <x> > Std Network Setup or Net <x> Setup > Network Card

Menu item	Description
View Card Status Connected Disconnected	Lets you view the connection status of the Network Card
View Card Speed	Lets you view the speed of a currently active network card
Network Address UAA LAA	Lets you view the network addresses

Menu item	Description
Job Timeout 0-225 seconds	Sets the amount of time in seconds that a network print job can take before it is canceled Notes: <ul style="list-style-type: none"> • 90 seconds is the factory default setting. • A setting value of 0 disables the timeout. • If a value of 1–9 is selected, then the setting is saved as 10.
Banner Page Off On	Allows the printer to print a banner page Note: Off is the factory default setting.

TCP/IP menu

Use the following menu items to view or set the TCP/IP information.

Note: This menu is available only for network models or printers attached to print servers.

This menu is available from the Network/Ports menu:

Network/Ports > Standard Network or Network <x> > Std Network Setup or Net <x> Setup > TCP/IP

Menu item	Description
Activate On Off	Activates TCP/IP Note: On is the factory default setting.
View Hostname	Lets you view the current TCP/IP hostname Note: This can be changed only from the Embedded Web Server.
IP Address	Lets you view or change the current TCP/IP Address Note: Manually setting the IP address sets the Enable DHCP and Enable Auto IP settings to Off. It also sets Enable BOOTP and Enable RARP to Off on systems that support BOOTP and RARP.
Netmask	Lets you view or change the current TCP/IP Netmask
Gateway	Lets you view or change the current TCP/IP Gateway
Enable DHCP On Off	Specifies the DHCP address and parameter assignment setting Note: On is the factory default setting.
Enable RARP On Off	Specifies the RARP address assignment setting Note: On is the factory default setting.
Enable BOOTP On Off	Specifies the BOOTP address assignment setting Note: On is the factory default setting.

Menu item	Description
AutoIP Yes No	Specifies the Zero Configuration Networking setting Note: Yes is the factory default setting.
Enable FTP/TFTP Yes No	Enables the built-in FTP server, which allows you to send files to the printer using the File Transfer Protocol. Note: Yes is the factory default setting.
Enable HTTP Server Yes No	Enables the built-in Web server (Embedded Web Server). When this is enabled, the printer can be monitored and managed remotely using a Web browser. Note: Yes is the factory default setting.
WINS Server Address	Lets you view or change the current WINS Server Address
Enable DDNS	Lets you view or change the current DDNS setting Note: Yes is the factory default setting.
Enable mDNS	Lets you view or change the current mDNS setting Note: Yes is the factory default setting.
DNS Server Address	Lets you view or change the current DNS Server Address

IPv6 menu

Use the following menu items to view or set the Internet Protocol version 6 (IPv6) information.

Note: This menu is available only for network models or printers attached to print servers.

This menu is available from the Network/Ports menu:

Network/Ports > Standard Network or **Network <x> > Std Network Setup** or **Net <x> Setup > IPv6**

Menu item	Description
Enable IPv6 On Off	Enables IPv6 in the printer Note: On is the factory default setting.
Auto Configuration On Off	Specifies whether the network adapter accepts the automatic IPv6 address configuration entries provided by a router Note: On is the factory default setting.
View Hostname View Address View Router Address	Lets you view the current setting Note: These settings can be changed only from the Embedded Web Server.
Enable DHCPv6 On Off	Enables DHCPv6 in the printer Note: On is the factory default setting.

Wireless menu

Use the following menu items to view or configure the wireless internal print server settings.

Note: This menu is available only for models connected to a wireless network.

This menu is available from the Network/Ports menu:

Network/Ports > Network <x> > Net <x> Setup > Wireless

Menu item	Description
Network Mode Infrastructure Ad hoc	Specifies the network mode Notes: <ul style="list-style-type: none"> Infrastructure mode lets the printer access a network using an access point. Ad hoc is the factory default setting. Ad hoc mode configures the printer for wireless networking directly between it and a computer.
Compatibility 802.11n 802.11b/g 802.11b/g/n	Specifies the wireless standard for the wireless network
Choose Network <list of available networks>	Lets you select an available network for the printer to use
View Signal Quality	Lets you view the quality of the wireless connection
View Security Mode	Lets you view the encryption method for the wireless connection. "Disabled" indicates that the wireless network is not encrypted.

AppleTalk menu

Menu item	Description
Activate Yes No	Activates or deactivates AppleTalk support Note: Yes is the factory default setting.
View Name	Shows the assigned AppleTalk name
View Address	Shows the assigned AppleTalk address
Set Zone <list of zones available on the network>	Provides a list of AppleTalk zones available on the network Note: The factory default setting is the default zone for the network. If no default zone exists, the zone marked with an * is the factory default setting.

NetWare menu

This menu is available from the Network/Ports menu:

Network/Ports > Standard Network or Network <x> > Std Network Setup or Net <x> Setup > NetWare

Menu item	Description
Activate Yes No	Activates NetWare support Note: No is the factory default setting.
View Login Name	Lets you view the assigned NetWare login name Note: This can be changed only from the Embedded Web Server.
Print Mode	Lets you view the assigned NetWare print mode Note: This can be changed only from the Embedded Web Server.
Network Number	Lets you view the assigned NetWare network number Note: This can be changed only from the Embedded Web Server.
Select IPX Frame Types Ethernet 802.2 Ethernet 802.3 Ethernet Type II Ethernet SNAP	Enables the Ethernet frame type setting Note: On is the factory default setting for all menu items.
Packet Burst Yes No	Reduces network traffic by allowing the transfer and acknowledgement of multiple data packets to and from the NetWare server Note: Yes is the factory default setting.
NSQ/GSQ Mode Yes No	Specifies the NSQ/GSQ Mode setting Note: Yes is the factory default setting.

LexLink menu

This menu is available from the Network/Ports menu:

Network/Ports > Standard Network or Network <x> > Std Network Setup or Net <x> Setup > LexLink menu

Menu item	Description
Activate On Off	Activates LexLink support Note: Off is the factory default setting.
View Nickname	Lets you view the assigned LexLink nickname Note: The LexLink nickname can be changed only from the Embedded Web Server.

Standard USB menu

Menu item	Description
PCL SmartSwitch On Off	Sets the printer to automatically switch to PCL emulation when a print job received through a USB port requires it, regardless of the default printer language Notes: <ul style="list-style-type: none"> • On is the factory default setting. • When the Off setting is used, the printer does not examine incoming data. • When the Off setting is used, the printer uses PostScript emulation if the PS SmartSwitch setting is On. It uses the default printer language specified in the Setup menu if the PS SmartSwitch setting is Off.
PS SmartSwitch On Off	Sets the printer to automatically switch to PS emulation when a print job received through a USB port requires it, regardless of the default printer language Notes: <ul style="list-style-type: none"> • On is the factory default setting. • When the Off setting is used, the printer does not examine incoming data. • When the Off setting is used, the printer uses PCL emulation if the PCL SmartSwitch setting is On. It uses the default printer language specified in the Setup menu if the PCL SmartSwitch setting is Off.
NPA Mode On Off Auto	Sets the printer to perform the special processing required for bidirectional communication following the conventions defined by the NPA protocol Notes: <ul style="list-style-type: none"> • Auto is the factory default setting. • Changing this setting from the printer control panel and then exiting the menus causes the printer to restart. The menu selection is updated.
USB Buffer Disabled Auto 3K to <maximum size allowed>	Sets the size of the USB input buffer Notes: <ul style="list-style-type: none"> • Auto is the factory default setting. • The Disabled setting turns off job buffering. Any jobs already buffered on the disk are printed before normal processing is resumed. • The USB buffer size value can be changed in 1-K increments. • The maximum size allowed depends on the amount of memory in the printer, the size of the other link buffers, and whether the Resource Save setting is On or Off. • To increase the maximum size range for the USB Buffer, disable or reduce the size of the parallel, serial, and network buffers. • Changing this setting from the printer control panel and then exiting the menus causes the printer to restart. The menu selection is updated.

Menu item	Description
Job Buffering Off On Auto	Temporarily stores jobs on the printer hard disk before printing Notes: <ul style="list-style-type: none"> • Off is the factory default setting. • The On setting buffers jobs on the printer hard disk. • The Auto setting buffers print jobs only if the printer is busy processing data from another input port. • Changing this setting from the printer control panel and then exiting the menus causes the printer to restart. The menu selection is updated.
Mac Binary PS On Off Auto	Sets the printer to process Macintosh binary PostScript print jobs Notes: <ul style="list-style-type: none"> • Auto is the factory default setting. • The Off setting filters print jobs using the standard protocol. • The On setting processes raw binary PostScript print jobs.
USB With ENA ENA Address ENA Netmask ENA Gateway	Sets the network address, netmask, or gateway information for an external print server that is attached to the printer using a USB cable. Note: This menu item is available only if the printer is attached to an external print server through the USB port.

Parallel <x> menu

This menu appears only if an optional parallel card is installed.

Menu item	Description
PCL SmartSwitch On Off	Sets the printer to automatically switch to PCL emulation when a print job received through a parallel port requires it, regardless of the default printer language Notes: <ul style="list-style-type: none"> • On is the factory default setting. • When the Off setting is used, the printer does not examine incoming data. • When the Off setting is used, the printer uses PostScript emulation if PS SmartSwitch is set to On. It uses the default printer language specified in the Setup menu if PS SmartSwitch is set to Off.
PS SmartSwitch On Off	Sets the printer to automatically switch to PS emulation when a print job received through a parallel port requires it, regardless of the default printer language Notes: <ul style="list-style-type: none"> • On is the factory default setting. • When the Off setting is used, the printer does not examine incoming data. • When the Off setting is used, the printer uses PCL emulation if PCL SmartSwitch is set to On. It uses the default printer language specified in the Setup menu if PCL SmartSwitch is set to Off.

Menu item	Description
NPA Mode On Off Auto	Sets the printer to perform the special processing required for bidirectional communication following the conventions defined by the NPA protocol Notes: <ul style="list-style-type: none"> • Auto is the factory default setting. • Changing this setting from the printer control panel and then exiting the menus causes the printer to restart. The menu selection is updated.
Parallel Buffer Disabled Auto 3K to <max size allowed>	Sets the size of the parallel input buffer Notes: <ul style="list-style-type: none"> • Auto is the factory default setting. • The Disabled setting turns off job buffering. Any jobs already buffered on the disk are printed before normal processing is resumed. • The parallel buffer size setting can be changed in 1K increments. • The maximum size allowed depends on the amount of memory in the printer, the size of the other link buffers, and whether Resource Save is set to On or Off. • To increase the maximum size range for the Parallel Buffer, disable or reduce the size of the USB, serial, and network buffers. • Changing this setting from the printer control panel and then exiting the menus causes the printer to restart. The menu selection is updated.
Job Buffering Off On Auto	Temporarily stores jobs on the printer hard disk before printing Notes: <ul style="list-style-type: none"> • Off is the factory default setting. • The Off setting does not buffer print jobs to the printer hard disk. • The On setting buffers jobs on the printer hard disk. • The Auto setting buffers print jobs only if the printer is busy processing data from another input port. • Changing this setting from the printer control panel and then exiting the menus causes the printer to restart. The menu selection is updated.
Advanced Status On Off	Enables bidirectional communication through the parallel port Notes: <ul style="list-style-type: none"> • On is the factory default setting. • The Off setting disables parallel port negotiation.
Protocol Standard Fastbytes	Specifies the parallel port protocol Notes: <ul style="list-style-type: none"> • Fastbytes is the factory default setting. It provides compatibility with most existing parallel ports and is the recommended setting. • The Standard setting tries to resolve parallel port communication problems.

Menu item	Description
Honor Init On Off	Determines whether or not the printer honors printer hardware initialization requests from the computer Notes: <ul style="list-style-type: none"> • Off is the factory default setting. • The computer requests initialization by activating the Init signal from the parallel port. Many personal computers activate the Init signal each time the computer is turned on.
Parallel Mode 2 On Off	Determines whether the parallel port data is sampled on the leading or trailing edge of strobe Notes: <ul style="list-style-type: none"> • On is the factory default setting. • This menu appears only if a standard or optional parallel port is available.
Mac Binary PS On Off Auto	Sets the printer to process Macintosh binary PostScript print jobs Notes: <ul style="list-style-type: none"> • Auto is the factory default setting. • The Off setting filters print jobs using the standard protocol. • The On setting processes raw binary PostScript print jobs.
Parallel With ENA ENA Address ENA Netmask ENA Gateway	Sets the network address, netmask, or gateway information for an external print server that is attached to the printer using a parallel cable. Note: This menu item is available only if the printer is attached to an external print server through a parallel port.

Serial <x> menu

This menu appears only if an optional serial card is installed.

Menu item	Description
PCL SmartSwitch On Off	Sets the printer to automatically switch to PCL emulation when a print job received through a serial port requires it, regardless of the default printer language Notes: <ul style="list-style-type: none"> • On is the factory default setting. • When the Off setting is used, the printer does not examine incoming data. • When the Off setting is used, the printer uses PostScript emulation if PS SmartSwitch is set to On. It uses the default printer language specified in the Setup menu if PS SmartSwitch is set to Off.

Menu item	Description
PS SmartSwitch On Off	Sets the printer to automatically switch to PS emulation when a print job received through a serial port requires it, regardless of the default printer language Notes: <ul style="list-style-type: none"> • On is the factory default setting. • When the Off setting is used, the printer does not examine incoming data. • When the Off setting is used, the printer uses PCL emulation if PCL SmartSwitch is set to On. It uses the default printer language specified in the Setup menu if PCL SmartSwitch is set to Off.
NPA Mode On Off Auto	Sets the printer to perform the special processing required for bidirectional communication following the conventions defined by the NPA protocol Notes: <ul style="list-style-type: none"> • Auto is the factory default setting. • When the On setting is used, the printer performs NPA processing. If the data is not in NPA format, it is rejected as bad data. • When the Off setting is used, the printer does not perform NPA processing. • When the Auto setting is used, the printer examines data, determines the format, and then processes it appropriately. • Changing this setting from the printer control panel and then exiting the menus causes the printer to restart. The menu selection is updated.
Serial Buffer Disabled Auto 3K to <maximum size allowed>	Sets the size of the serial input buffer Notes: <ul style="list-style-type: none"> • Auto is the factory default setting. • The Disabled setting turns off job buffering. Any jobs already buffered on the disk are printed before normal processing is resumed. • The serial buffer size setting can be changed in 1-K increments. • The maximum size allowed depends on the amount of memory in the printer, the size of the other link buffers, and whether Resource Save is set to On or Off. • To increase the maximum size range for the Serial Buffer, disable or reduce the size of the parallel, USB, and network buffers. • Changing this setting from the printer control panel and then exiting the menus causes the printer to restart. The menu selection is updated.
Job Buffering Off On Auto	Temporarily stores jobs on the printer hard disk before printing Notes: <ul style="list-style-type: none"> • Off is the factory default setting. • The Off setting does not buffer print jobs to the hard disk. • The On setting buffers jobs on the printer hard disk. • The Auto setting buffers print jobs only if the printer is busy processing data from another input port. • Changing this setting from the printer control panel and then exiting the menus causes the printer to restart. The menu selection is updated.

Menu item	Description
Serial Protocol DTR DTR/DSR XON/XOFF XON/XOFF/DTR XON/XOFF/DTRDSR	Selects the hardware and software handshaking settings for the serial port Notes: <ul style="list-style-type: none"> • DTR is the factory default setting. • DTR/DSR is a hardware handshaking setting. • XON/XOFF is a software handshaking setting. • XON/XOFF/DTR and XON/XOFF/DTR/DSR are combined hardware and software handshaking settings.
Robust XON On Off	Determines whether or not the printer communicates availability to the computer Notes: <ul style="list-style-type: none"> • Off is the factory default setting. • This menu item applies only to the serial port if Serial Protocol is set to XON/XOFF.
Baud 1200 2400 4800 9600 19200 38400 57600 115200 138200 172800 230400 345600	Specifies the rate at which data can be received through the serial port Notes: <ul style="list-style-type: none"> • 9600 is the factory default setting. • 138200, 172800, 230400, and 345600 baud rates are displayed only in the Standard Serial menu. These settings do not appear in the Serial Option or Serial Option 2 menus.
Data Bits 7 8	Specifies the number of data bits that are sent in each transmission frame Note: 8 is the factory default setting.
Parity Even Odd None Ignore	Sets the parity for serial input and output data frames Note: None is the factory default setting.
Honor DSR On Off	Determines whether the printer uses the DSR Signal. DSR is a handshaking signal used by most serial cables. Notes: <ul style="list-style-type: none"> • Off is the factory default setting. • The serial port uses DSR to distinguish data sent by the computer from data created by electrical noise in the serial cable. The electrical noise can cause stray characters to print. Select On to prevent stray characters from printing. • This menu item appears only if Serial RS-232/RS-422 is set to RS 232.

Security menu

Miscellaneous menu

Menu item	Description
Panel Logins Login failures Failure time frame Lockout time Login timeout	Limits the number and time frames of failed login attempts from the printer control panel before <i>all</i> users are locked out Notes: <ul style="list-style-type: none"> • “Login failures” specifies the number of failed login attempts before users are locked out. Settings range from 1–50. 3 attempts is the factory default setting. • “Failure time frame” specifies the time frame during which failed login attempts can be made before users are locked out. Settings range from 1–60 minutes. 5 minutes is the factory default setting. • “Lockout time” specifies how long users are locked out after exceeding the login failures limit. Settings range from 0–60 minutes. 5 minutes is the factory default setting. 0 indicates the printer does not impose a lockout time. • “Login timeout” specifies how long the printer remains idle on the Home screen before automatically logging the user off. Settings range from 1–900 seconds. 300 seconds is the factory default setting.
Remote Logins Login failures Failure time frame Lockout time Login timeout	Limits the number and time frames of failed login attempts from a computer before <i>all</i> remote users are locked out Notes: <ul style="list-style-type: none"> • “Login failures” specifies the number of failed login attempts before users are locked out. Settings range from 1–50. 3 attempts is the factory default setting. • “Failure time frame” specifies the time frame during which failed login attempts can be made before users are locked out. Settings range from 1–60 minutes. 5 minutes is the factory default setting. • “Lockout time” specifies how long a user is locked out after exceeding the login failures limit. Settings range from 0–60 minutes. 5 minutes is the factory default setting. 0 indicates the printer does not impose a lockout time. • “Login timeout” specifies how long the remote interface remains idle before automatically logging the user off. Settings range from 1–900 seconds. 300 seconds is the factory default setting.

Confidential Print menu

Menu item	Description
Max Invalid PIN Off 2–10	Limits the number of times an invalid PIN can be entered Notes: <ul style="list-style-type: none"> • Off is the default setting. • This menu item appears only if a printer hard disk is installed. • Once a limit is reached, the jobs for that user name and that PIN are deleted.

Menu item	Description
Job Expiration Off 1 hour 4 hours 24 hours 1 week	<p>Limits the amount of time a confidential job stays in the printer before it is deleted</p> <p>Notes:</p> <ul style="list-style-type: none"> • Off is the default setting. • If the Job Expiration setting is changed while confidential jobs reside on the printer RAM or printer hard disk, the expiration time for those print jobs does not change to the new default value. • If the printer is turned off, all confidential jobs held in printer RAM are deleted.

Disk Wiping menu

Menu item	Description
Automatic Wiping Off On	<p>Disk Wiping erases <i>only</i> print job data that <i>is not</i> currently in use by the file system from the printer hard disk. All permanent data on the printer hard disk is preserved, such as downloaded fonts, macros, and held jobs.</p> <p>Automatic Wiping marks all disk space used by a previous job and does not permit the file system to reuse this space until it has been sanitized.</p> <p>Only Automatic Wiping enables users to activate disk wiping without having to take the printer offline for an extended amount of time.</p> <p>Notes:</p> <ul style="list-style-type: none"> • This menu item appears only if a formatted, non-defective printer hard disk is installed. • Off is the default setting. • Due to the large amount of resources required for Automatic Wiping, activating this option may decrease printer performance, especially if the printer requires hard disk space faster than it can be wiped and returned to service.
Manual Wiping Start now Do not start now	<p>Disk Wiping erases <i>only</i> print job data that <i>is not</i> currently in use by the file system from the printer hard disk. All permanent data on the printer hard disk is preserved, such as downloaded fonts, macros, and held jobs.</p> <p>Manual Wiping overwrites all disk space that has been used to hold data from a print job that has been processed (i.e. printed). This type of wipe <i>does not</i> erase any information related to an unprocessed print job.</p> <p>Notes:</p> <ul style="list-style-type: none"> • This menu item appears only if a formatted, non-defective printer hard disk is installed. • "Do not start now" is the default setting. • If the Disk Wiping access control is activated, then a user must successfully authenticate and have the required authorization in order to initiate the disk wipe.

Menu item	Description
Automatic Method Single pass Multiple pass	<p>Disk Wiping erases <i>only</i> print job data that <i>is not</i> currently in use by the file system from the printer hard disk. All permanent data on the printer hard disk is preserved, such as downloaded fonts, macros, and held jobs.</p> <p>Notes:</p> <ul style="list-style-type: none"> • This menu item appears only if a formatted, non-defective printer hard disk is installed. • Single pass is the default setting. • Highly confidential information should be wiped using the Multiple pass method <i>only</i>.
Manual Method Single pass Multiple pass	<p>Disk Wiping erases <i>only</i> print job data that <i>is not</i> currently in use by the file system from the printer hard disk. All permanent data on the printer hard disk is preserved, such as downloaded fonts, macros, and held jobs.</p> <p>Both manual and scheduled wiping allow the file system to reuse marked disk space without first having to wipe it.</p> <p>Notes:</p> <ul style="list-style-type: none"> • This menu item appears only if a formatted, non-defective printer hard disk is installed. • Single pass is the default setting. • Highly confidential information should be wiped using the Multiple Pass method <i>only</i>.
Scheduled Method Single pass Multiple pass	<p>Disk Wiping erases <i>only</i> print job data that <i>is not</i> currently in use by the file system from the printer hard disk. All permanent data on the printer hard disk is preserved, such as downloaded fonts, macros, and held jobs.</p> <p>Both manual and scheduled wiping allow the file system to reuse marked disk space without first having to wipe it.</p> <p>Notes:</p> <ul style="list-style-type: none"> • This menu item appears only if a formatted, non-defective printer hard disk is installed. • Single pass is the default setting. • Highly confidential information should be wiped using the Multiple Pass method <i>only</i>. • Scheduled wipes are initiated <i>without</i> displaying a user warning or confirmation message.

Security Audit Log menu

Menu item	Description
Export Log	<p>Enables an authorized user to export the security log</p> <p>Notes:</p> <ul style="list-style-type: none"> • To export the log from the printer control panel, a flash drive must be attached to the printer. • From the Embedded Web Server, the log can be downloaded to a computer.

Menu item	Description
Delete Log Delete now Do not delete	Specifies whether audit logs are deleted Note: Delete Now is the factory default setting.
Configure Log Enable Audit Enable Remote Syslog Remote Syslog Facility Severity of events to log	Specifies whether and how the audit logs are created Note: Factory default settings enable the security audit log.

Set Date/Time menu

Menu item	Description
View Date/Time	Lets you view the current date and time settings for the printer
Set Date/Time <input type="text" value="<input date/time>"/>	Note: Date/Time is set in YYYY-MM-DD HH:MM format.
Time Zone <input type="text" value="<list of time zones>"/>	Note: GMT is the factory default setting.
Observe DST On Off	Note: On is the factory default setting and uses the applicable Daylight Saving Time associated with the Time Zone setting.
Enable NTP On Off	Enables Network Time Protocol, which synchronizes the clocks of devices on a network Note: On is the factory default setting.

Settings menu

General Settings menu

Menu item	Description
Display Language English Francais Deutsch Italiano Espanol Dansk Norsk Nederlands Svenska Portuguese Suomi Russian Polski Turkce Korean	Sets the language of the text appearing on the display Note: All languages may not be available for all printers.
Eco-Mode Off Energy Energy/Paper Paper	Minimizes the use of energy, paper, or specialty media Notes: <ul style="list-style-type: none"> • Off is the factory default setting. Off resets the printer to its factory default settings. • The Energy setting minimizes the power used by the printer. Performance may be affected, but print quality is not. • Paper minimizes the amount of paper and specialty media needed for a print job by duplexing each page. Performance may be affected, but print quality is not. • Energy/Paper minimizes the use of power and of paper and specialty media.
ADF Loaded Beep Enabled Disabled	Specifies whether the ADF emits a beep when paper is loaded Note: Enabled is the factory default setting.
Quiet Mode Off On	Reduces the amount of noise produced by the printer Notes: <ul style="list-style-type: none"> • Off is the factory default setting. • On configures the printer to produce as little noise as possible.

Menu item	Description
Run Initial setup Yes No	Instructs the printer to run the setup wizard Notes: <ul style="list-style-type: none"> • Yes is the factory default setting. • After completing the setup wizard by selecting Done at the Country select screen, the default becomes No.
Keyboard Keyboard Type English Francais Francais Canadien Deutsch Italiano Espanol Dansk Norsk Nederlands Svenska Suomi Portuguese Russian Polski Swiss German Swiss French Korean Turkce Custom Key <x> Accents/Symbols Tab On Off Russian/Polish Tab On Off Korean Tab On Off	Specifies a language and custom key information for the printer control panel keyboard. The additional tabs enable access to accent marks and symbols from the printer control panel keyboard.
Paper Sizes U.S. Metric	Specifies the printer factory default measurements. The default is determined by the country/region selection in the initial setup wizard.
Scan to PC Port Range <port range>	Specifies a valid port range for printers behind a port-blocking firewall. The valid ports are specified by two sets of numbers separated by a semicolon. Note: 9751:12000 is the factory default setting.

Menu item	Description
<p>Displayed Information</p> <ul style="list-style-type: none"> Left side Right side Custom Text <x> <ul style="list-style-type: none"> <text entry> Cartridge levels on status screen <ul style="list-style-type: none"> On Off Black Toner <ul style="list-style-type: none"> When to Display <ul style="list-style-type: none"> Display Do not display Message to Display <ul style="list-style-type: none"> Default Alternate Default Message <ul style="list-style-type: none"> <text entry> Alternate Message <ul style="list-style-type: none"> <text entry> 	<p>Specifies what is displayed on the upper left and right corners of the home screen</p> <p>For the Left side and Right side options, choose from the following options:</p> <ul style="list-style-type: none"> Model Name None IP Address Hostname Contact Name Location Date/Time mDNS/DDNS Service Name Zero Configuration Name Custom Text <x> <p>Notes:</p> <ul style="list-style-type: none"> • IP Address is the factory default setting for Left side. • Date/Time is the factory default setting for Right side. • Do not display is the factory default setting for When to Display. • Default is the factory default setting for Message to Display.
<p>Displayed Information (continued)</p> <ul style="list-style-type: none"> Paper Jam Load Paper Service Errors 	<p>The displayed information for Paper Jam, Load Paper, and Service Errors can be customized with the following options:</p> <ul style="list-style-type: none"> Activate <ul style="list-style-type: none"> Yes No Message to Display <ul style="list-style-type: none"> Default Alternate Default Message <ul style="list-style-type: none"> <text entry> Alternate Message <ul style="list-style-type: none"> <text entry> <p>Notes:</p> <ul style="list-style-type: none"> • No is the factory default setting for Activate. • Default is the factory default setting for Type of Message to Display.

Menu item	Description
Home screen customization Change Language Copy Copy Shortcuts Fax Fax Shortcuts E-mail E-mail Shortcuts FTP FTP Shortcuts Search Held Jobs Held Jobs USB Drive Profiles Bookmarks Jobs by user	Additional buttons can be added to the Home screen, and default buttons can be removed. Available selections for each button are: Display Do Not Display
Date Format MM-DD-YYYY DD-MM-YYYY YYYY-MM-DD	Formats the printer date
Time Format 12 hour A.M./P.M. 24 hour clock	Formats the printer time
Screen Brightness 20–100	Specifies the brightness of the printer control panel screen
One Page Copy On Off	Sets the copies from the scanner glass to only one page at a time Note: Off is the factory default setting.
Output Lighting Standard Bin LED Normal/Standby Mode Bright Dim Off Power Saver Bright Dim Off	Sets the amount of light from the standard bin or an optional output bin Notes: <ul style="list-style-type: none"> • In Normal/Standby Mode, the factory default is Bright. • In Power Saver Mode, the factory default is Dim.
Show Bookmarks Yes No	Specifies whether bookmarks are displayed from the Held Jobs area Note: Yes is the factory default setting. When On is selected, bookmarks appear in the Held Jobs area.

Menu item	Description
Allow Background Removal On Off	Specifies whether image background removal is allowed during copy, fax, e-mail, FTP, or scan to USB Note: On is the factory default setting. The background of the image will be removed.
Allow Custom Job Scans On Off	Lets you scan multiple jobs to one file Notes: <ul style="list-style-type: none"> • A printer hard disk must be installed in the printer and operating properly for this menu item to be available. • On is the factory default setting. If On is selected, the Allow Custom Job Scans setting can be enabled for specific jobs.
Scanner Jam Recovery Job level Page level	Specifies how a scanned job should be reloaded if a paper jam occurs in the ADF Notes: <ul style="list-style-type: none"> • If Job level is selected, the entire job must be rescanned if any pages jam. • If Page level is selected, rescan from the jammed page forward.
Web Page Refresh Rate 30–300	Specifies the number of seconds between Embedded Web Server refreshes Note: 120 seconds is the factory default setting.
Contact Name	Specifies a contact name for the printer
Location	Specifies the location of the printer Note: The location will be stored on the Embedded Web Server.
Alarms Alarm Control Cartridge Alarm	Sets an alarm to sound when the printer requires operator intervention Available selections for each alarm type are: Off Single Notes: <ul style="list-style-type: none"> • Single is the factory default setting for Alarm Control. Single sounds three quick beeps. • Off is the factory default setting for Toner Alarm. Off means no alarm will sound.
Timeouts Standby Mode Disabled 2–240	Specifies the number of minutes of inactivity before the system enters a lower power state Note: 15 minutes is the factory default setting.

Menu item	Description
Timeouts Power Saver Mode Disabled 2–240	Specifies the number of minutes of inactivity before some systems begin entering a minimum power state. Notes: <ul style="list-style-type: none"> • 30 minutes is the factory default setting. • Power Saver does not interact with Standby Mode.
Timeouts Screen Timeout 15–300	Sets the amount of time in seconds the printer waits before returning the printer display to a Ready state Note: 30 seconds is the factory default setting.
Timeouts Print Timeout Disabled 1–255	Sets the amount of time in seconds the printer waits to receive an end-of-job message before canceling the remainder of the print job Notes: <ul style="list-style-type: none"> • 90 seconds is the factory default setting. • When the timer expires, any partially printed page still in the printer is printed, and then the printer checks to see if any new print jobs are waiting. • Print Timeout is available only when using PCL or PPDS emulation. This setting has no effect on PostScript emulation print jobs.
Timeouts Wait Timeout Disabled 15–65535	Sets the amount of time in seconds the printer waits for additional data before canceling a print job Notes: <ul style="list-style-type: none"> • 40 seconds is the factory default setting. • Wait Timeout is available only when the printer is using PostScript emulation. This setting has no effect on PCL or PPDS emulation print jobs.
Timeouts Job Hold Timeout Disabled 5–255	Sets the amount of time the printer waits for user intervention before it holds jobs that require unavailable resources and continues to print other jobs in the print queue Notes: <ul style="list-style-type: none"> • 30 seconds is the factory default setting. • This menu item appears only when a printer hard disk is installed.
Print Recovery Auto Continue Disabled 5–255	Lets the printer automatically continue printing from certain offline situations when not resolved within the specified time period Notes: <ul style="list-style-type: none"> • Disabled is the factory default setting. • 5–255 is a range of time in seconds.

Menu item	Description
Print Recovery Jam Recovery On Off Auto	Specifies whether the printer reprints jammed pages Notes: <ul style="list-style-type: none"> • Auto is the factory default setting. The printer reprints jammed pages unless the memory required to hold the pages is needed for other printer tasks. • On sets the printer to always reprint jammed pages. • Off sets the printer to never reprint jammed pages.
Print Recovery Page Protect On Off	Lets the printer successfully print a page that may not have printed otherwise Notes: <ul style="list-style-type: none"> • Off is the factory default setting. Off prints a partial page when there is not enough memory to print the whole page. • On sets the printer to process the whole page so that the entire page prints.
Factory Defaults Do Not Restore Restore Now	Returns the printer settings to the factory default settings Notes: <ul style="list-style-type: none"> • Do Not Restore is the factory default setting. Do Not Restore keeps the user-defined settings. • Restore returns all printer settings to the factory default settings except Network/Ports menu settings. All downloads stored in RAM are deleted. Downloads stored in flash memory or on a printer hard disk are not affected.

Copy Settings menu

Menu item	Description
Content Text/Photo Photograph Printed Image Text	Specifies the type of content contained in the copy job Notes: <ul style="list-style-type: none"> • Text/Photo is the factory default setting. Text/Photo is used when the original documents are a mixture of text and graphics or pictures. • Photograph tells the scanner to pay extra attention to graphics and pictures. This setting increases the time it takes to scan, but emphasizes a reproduction of the full dynamic range of tones in the original document. This increases the amount of information saved. • Printed Image is used when jobs are composed primarily of images. Printed Image converts the images to halftone. Halftoning makes a grayscale or color image printable by transforming it to a pattern of small spots with a limited number of colors. • Text emphasizes sharp, black, high-resolution text against a clean, white background.

Menu item	Description
Sides (Duplex) 1 sided to 1 sided 1 sided to 2 sided 2 sided to 1 sided 2 sided to 2 sided	Specifies whether an original document is duplex (two-sided) or simplex (one-sided), and then specifies whether the copy should be duplex or simplex Notes: <ul style="list-style-type: none"> • 1 sided to 1 sided—The original page has printing on one side. The copied page will have printing on one side. • 1 sided to 2 sided—The original page has printing on one side. The copied page will have printing on both sides. For example, if the original is six sheets, the copy is three sheets with printing on both sides. • 2 sided to 1 sided—The original page has printing on both sides. The copied page will have printing on only one side. For example, if the original draft is three sheets of paper with an image on each side of each sheet, then the copy is six sheets with only one image on one side of each sheet. • 2 sided to 2 sided—The original page has printing on both sides. The copy mimics the original exactly.
Paper Saver Off 2 on 1 Portrait 2 on 1 Landscape 4 on 1 Portrait 4 on 1 Landscape	Sets two or four sheets of an original document together on the same page Note: Off is the factory default setting.
Print Page Borders On Off	Specifies whether a border is printed around the edge of the page at the margins Note: On is the factory default setting.
Collate On Off	Keeps the pages of a print job stacked in sequence when making multiple copies of the job Note: On is the factory default setting.
Original Size Letter Legal Executive Folio Statement Oficio (Mexico) Universal A4 A5 A6 JIS B5 ID Card Custom Scan Size <x> Book Original Business Card 3 x 5 in. 4 x 6 in.	Specifies the paper size of the original document

Menu item	Description
Copy To Source Tray <x> Manual Feeder Auto Size Match	Specifies the paper source for copy jobs Note: Tray 1 is the factory default setting.
Transparency Separators On Off	Places a sheet of paper between transparencies Note: On is the factory default setting.
Separator Sheets None Between Copies Between Jobs Between Pages	Places a sheet of paper between pages, copies, or jobs based on the value selected Note: None is the factory default setting.
Separator Sheet Source Tray <x> Manual Feeder	Specifies a paper source
Darkness 1–9	Specifies the level of darkness for the copy job
Number of Copies	Specifies the number of copies for the copy job
Header/Footer Top left Top left Off Date/Time Page number Bates number Custom text Print on All pages First page only All but first page Enter custom text	Specifies header/footer information for the top left of the page Notes: <ul style="list-style-type: none"> • Off is the factory default setting for Top left. • “All pages” is the factory default setting for Print on.

Menu item	Description
<p>Header/Footer</p> <p>Top middle</p> <p> Top middle</p> <p> Off</p> <p> Date/Time</p> <p> Page number</p> <p> Bates number</p> <p> Custom text</p> <p>Print on</p> <p> All pages</p> <p> First page only</p> <p> All but first page</p> <p>Enter custom text</p>	<p>Specifies header/footer information for the middle of the page</p> <p>Notes:</p> <ul style="list-style-type: none"> • Off is the factory default setting for Top middle. • “All pages” is the factory default setting for Print on.
<p>Header/Footer</p> <p>Top right</p> <p> Top right</p> <p> Off</p> <p> Date/Time</p> <p> Page number</p> <p> Bates number</p> <p> Custom text</p> <p>Print on</p> <p> All pages</p> <p> First page only</p> <p> All but first page</p> <p>Enter custom text</p>	<p>Specifies header/footer information for the top right of the page</p> <p>Notes:</p> <ul style="list-style-type: none"> • Off is the factory default setting for Top right. • “All pages” is the factory default setting for Print on.
<p>Header/Footer</p> <p>Bottom left</p> <p> Bottom left</p> <p> Off</p> <p> Date/Time</p> <p> Page number</p> <p> Bates number</p> <p> Custom text</p> <p>Print on</p> <p> All pages</p> <p> First page only</p> <p> All but first page</p> <p>Enter custom text</p>	<p>Specifies header/footer information for the bottom left of the page</p> <p>Notes:</p> <ul style="list-style-type: none"> • Off is the factory default setting for Bottom left. • “All pages” is the factory default setting for Print on.

Menu item	Description
Header/Footer Bottom middle Bottom middle Off Date/Time Page number Bates number Custom text Print on All pages First page only All but first page Enter custom text	Specifies header/footer information for the bottom middle of the page Notes: <ul style="list-style-type: none"> • Off is the factory default setting for Bottom middle. • “All pages” is the factory default setting for Print on.
Header/Footer Bottom right Bottom right Off Date/Time Page number Bates number Custom text Print on All pages First page only All but first page Enter custom text	Specifies header/footer information for the bottom right of the page Notes: <ul style="list-style-type: none"> • Off is the factory default setting for Bottom right. • “All pages” is the factory default setting for Print on.
Overlay Off Confidential Copy Draft Urgent Custom	Specifies overlay text that is printed on each page of the copy job Note: Off is the factory default setting.
Custom Overlay	Specifies custom overlay text
Allow priority copies On Off	Allows interruption of a print job to copy a page or document Note: On is the factory default setting.
Custom Job scanning On Off	Lets you copy in a single copy job a document that contains mixed paper sizes Notes: <ul style="list-style-type: none"> • Off is the factory default setting. • This menu item appears only if a valid printer hard drive is installed.

Menu item	Description
Allow Save as Shortcut On Off	Lets you save custom copy settings as shortcuts Note: On is the factory default setting.
Background Removal -4 to +4	Adjusts the amount of background visible on a copy Note: 0 is the factory default setting.
Auto Center On Off	Lets you automatically center the copy on the page Note: Off is the factory default setting.
Color Dropout Color Dropout None Red Green Blue Default Red Threshold 0–255 Default Green Threshold 0–255 Default Blue Threshold 0–255	Specifies which color to drop during copies, and how much to increase or decrease the dropout Notes: <ul style="list-style-type: none"> • None is the factory default setting for Color Dropout. • 128 is the factory default setting for each color threshold.
Contrast 0–5 Best for content	Specifies the contrast used for the copy job Note: “Best for content” is the factory default setting.
Mirror Image On Off	Creates a mirror image of the original document Note: Off is the factory default setting.
Negative Image On Off	Creates a negative image of the original document Note: Off is the factory default setting.
Shadow Detail -4 to +4	Adjusts the amount of shadow detail visible on a copy Note: 0 is the factory default setting.
Scan edge to edge On Off	Specifies if the original document is scanned edge-to-edge prior to copying Note: Off is the factory default setting.
Sharpness 0–5	Adjusts the sharpness of a copy Note: 3 is the factory default setting.

Menu item	Description
Sample Copy On Off	Creates a sample copy of the original document Notes: <ul style="list-style-type: none"> • Off is the factory default setting. • A printer hard disk must be installed in the printer and operating properly for this menu item to be available. • This menu item appears only for collated copy sets.

Fax Settings menu

Fax Mode (Analog Fax Setup) menu

Analog Fax Setup mode sends the fax job by way of a telephone line.

General Fax Settings

Menu item	Description
Station Name	Specifies the name of the fax within the printer
Station Number	Specifies a number associated with the fax
Station ID Station Name Station Number	Specifies how the fax is identified to recipients in the fax header
Enable Manual Fax On Off	Sets the printer to fax manually only, which requires a line splitter and a telephone hand set Notes: <ul style="list-style-type: none"> • Use a regular telephone to answer an incoming fax job and to dial a fax number. • Touch # 0 on the numeric keypad to go directly to the Manual Fax function.
Memory Use All receive Mostly receive Equal Mostly sent All send	Defines the allocation of non-volatile memory between sending and receiving fax jobs Notes: <ul style="list-style-type: none"> • “All receive” specifies that all the memory is set to receive fax jobs. • “Mostly receive” specifies that most of the memory is set to receive fax jobs. • Equal is the factory default setting. Equal splits the memory for sending and receiving fax jobs into equal amounts. • “Mostly sent” specifies that most of the memory is set to send fax jobs. • “All send” specifies that all the memory is set to send fax jobs.
Cancel Faxes Allow Don't Allow	Specifies whether the user may cancel fax jobs Note: If Cancel Faxes is not enabled, it does not appear as an option.

Menu item	Description
Caller ID FSK DTMF	Specifies the type of caller ID being used Notes: <ul style="list-style-type: none"> • FSK is the factory default setting. • This option appears only when the selected country/region supports multiple caller ID patterns.
Fax number masking Off From left From right	Specifies the direction from which digits are masked in an outgoing fax number Note: The number of characters masked is determined by the “Digits to mask” setting.
Digits to mask 0–58	Specifies the number of digits to mask in an outgoing fax number

Fax Cover Page

Menu item	Description
Fax Cover Page Off by default On by default Never Use Always Use Include To field On Off Include From field On Off From Include Message field On Off Message Include Logo On Off Include Footer <x> Footer <x>	Configures the fax cover page Note: Off is the factory default setting for all Fax Cover Page options.

Fax Send Settings

Menu item	Description
Resolution Standard Fine Super Fine Ultra Fine	Specifies quality in dots per inch (dpi). A higher resolution gives greater print quality, but it increases the fax transmission time for outgoing faxes. Note: Standard is the factory default setting.
Original Size Letter Legal Executive Folio Statement Oficio (Mexico) Universal Mixed Sizes A4 A5 A6 JIS B5 ID Card Custom Scan Size <x> Book Original Business Card 4 x 6 in. 3 x 5 in.	Specifies the paper size of the document that is being scanned Note: Letter is the US factory default setting. A4 is the international factory default setting.
Duplex Off Long edge Short edge	Specifies how the text and graphics are oriented on the page Notes: <ul style="list-style-type: none"> • Off is the factory default setting. • Long edge assumes binding along the long edge of the page (left edge for portrait orientation and top edge for landscape orientation). • Short edge assumes binding along the short edge of the page (top edge for portrait orientation and left edge for landscape orientation).
Content Text Text/Photo Photograph	Specifies the type of content that will be scanned to fax Notes: <ul style="list-style-type: none"> • Text is used when the document is mostly text. • Text/Photo is the factory default setting. Text/Photo is used when the documents are mostly text or line art. • Photograph is used when the document is a high-quality photograph or inkjet print.
Darkness 1–9	Lightens or darkens the output Note: 5 is the factory default setting.
Dial Prefix	A numeric entry field is provided to enter numbers

Menu item	Description
Dialing Prefix Rules Prefix Rule <x>	Establishes a dialing prefix rule
Automatic Redial 0–9	Specifies the number of times the printer tries to send the fax to a specified number Note: 5 is the factory default setting.
Redial Frequency 1–200	Specifies the number of minutes between redials Note: 3 is the factory default setting.
Behind a PABX Yes No	Enables switchboard blind dialing without a dial tone Note: No is the factory default setting.
Enable ECM Yes No	Enables Error Correction Mode for fax jobs Note: Yes is the factory default setting.
Enable Fax Scans On Off	Lets you send faxes by scanning at the printer Note: On is the factory default setting.
Driver to fax Yes No	Allows driver to fax jobs to be sent by the printer Note: Yes is the factory default setting.
Allow Save as Shortcut On Off	Lets you save fax numbers as shortcuts in the printer Note: On is the factory default setting.
Dial Mode Tone Pulse	Specifies the dialing sound, either as a tone or a pulse. Note: Tone is the factory default setting.
Max Speed 2400 4800 9600 14400 33600	Specifies the maximum speed in baud at which faxes are sent Note: 33600 is the factory default setting.
Custom Job scanning On Off	Lets you scan a document that contains mixed paper sizes into a single file Notes: <ul style="list-style-type: none"> • A printer hard disk must be installed in the printer and operating properly for this menu item to be available. • On is the factory default setting.
Scan Preview On Off	Specifies whether a preview will appear on the display for scan jobs Notes: <ul style="list-style-type: none"> • A printer hard disk must be installed in the printer and operating properly for this menu item to be available. • Off is the factory default setting.

Menu item	Description
Background Removal -4 to +4	Adjusts the amount of background visible on a copy Note: 0 is the factory default setting.
Color Dropout Color Dropout None Red Green Blue Default Red Threshold 0–255 Default Green Threshold 0–255 Default Blue Threshold 0–255	Specifies which color to drop during faxing, and how much to increase or decrease the dropout Notes: <ul style="list-style-type: none"> • None is the factory default setting for Color Dropout. • 128 is the factory default setting for each color threshold.
Contrast Best for content 0–5	Specifies the contrast of the output Note: “Best for content” is the factory default setting.
Mirror Image On Off	Creates a mirror image of the original document Note: Off is the factory default setting.
Negative Image On Off	Creates a negative image of the original document Note: Off is the factory default setting.
Shadow Detail -4 to +4	Adjusts the amount of shadow detail visible on a fax Note: 0 is the factory default setting.
Scan edge to edge On Off	Specifies if the original document is scanned edge-to-edge prior to faxing Note: Off is the factory default setting.
Sharpness 0–5	Adjusts the sharpness of a fax Note: 3 is the factory default setting.
Enable Color Fax Scans On by default Never use Always use Off by default	Enables color faxing Note: “Off by default” is the factory default setting.
Auto Convert Color Faxes to Mono Faxes On Off	Converts all outgoing faxes to black and white Note: On is the factory default setting.

Fax Receive Settings

Menu item	Description
Enable Fax Receive On Off	Allows fax jobs to be received by the printer Note: On is the factory default setting.
Fax Job Waiting None Toner Toner and Supplies	Allows a fax to be held until toner or supplies are replaced Notes: <ul style="list-style-type: none"> • This menu item appears only if a hard disk is supported and installed. • None is the factory default setting.
Rings to Answer 1–25	Specifies the number of rings before answering an incoming fax job Note: 3 is the factory default setting.
Auto Reduction On Off	Scales an incoming fax job so it fits the size of the paper loaded in the designated fax source Note: On is the factory default setting.
Paper Source Auto Tray <x> Multi-Purpose Feeder	Specifies the paper source selected to supply paper for the printer to print an incoming fax Note: Auto is the factory default setting.
Separator Sheets None After job Before job	Places a sheet of paper before or after a received fax. Note: None is the factory default setting.
Separator Sheet Source Tray <x> Manual feeder	Specifies a paper source. Note: Tray <x> is the factory default setting.
Sides (Duplex) On Off	Enables duplex printing (two-sided printing) for incoming fax jobs Note: Off is the factory default setting.
Fax Footer On Off	Prints the transmission information at the bottom of each page from a received fax Note: On is the factory default setting.
Max Speed 2400 4800 9600 14400 33600	Specifies the maximum speed in baud at which faxes are received Note: 33600 is the factory default setting.
Fax Forwarding Forward Print Print and Forward	Enables forwarding of received faxes to another recipient

Menu item	Description
Forward to Fax E-mail FTP LDSS eSF	Specifies the type of recipient to which faxes will be forwarded Note: This item is available only from the printer Embedded Web Server.
Forward to Shortcut	Lets you enter the shortcut number which matches the recipient type (Fax, E-mail, FPT, LDSS, or eSF)
Block No Name Fax On Off	Enables blocking of incoming faxes sent from devices with no station ID specified Note: Off is the factory default setting.
Banned Fax List	Enables the list of banned fax numbers stored in the printer
Holding Faxes Held Fax Mode Off Always On Manual Scheduled Fax Holding Schedule	Enables fax holding all of the time or according to a set schedule Note: Off is the factory default setting.
Enable Color Fax Receive On Off	Lets you receive a color fax Note: On is the factory default setting.

Fax Log Settings

Menu item	Description
Transmission Log Print log Do not print log Print only for error	Enables printing of a transmission log after each fax job Note: Print log is the factory default setting.
Receive Error Log Print Never Print on Error	Enables printing of a receive error log following a receive error Note: Print Never is the factory default setting.
Auto Print Logs On Off	Enables automatic printing of fax logs Notes: <ul style="list-style-type: none"> • Logs print after every 200 jobs. • On is the factory default setting.
Log Paper Source Tray <x> Manual Feeder	Selects the source of the paper used for printing logs Note: Tray <x> is the factory default setting.

Menu item	Description
Logs Display Remote Station Name Dialed Number	Specifies whether printed logs display the dialed number or the station name returned Note: Remote Station Name is the factory default setting.
Enable Job Log On Off	Enables access to the Fax Job log Note: On is the factory default setting.
Enable Call Log On Off	Enables access to the Fax Call log Note: On is the factory default setting.

Speaker Settings

Menu item	Description
Speaker Mode Always Off On until Connected Always On	Notes: <ul style="list-style-type: none"> • Always Off turns the speaker off. • On until Connected is the factory default setting. The speaker is on and issues a noise until the fax connection is made. • Always On turns the speaker on.
Speaker Volume High Low	Controls the volume setting Note: High is the factory default setting.
Ringer Volume On Off	Controls the fax speaker ringer volume Note: On is the factory default setting.

Distinctive Rings

Menu item	Description
Single Ring On Off	Answers calls with a one-ring pattern Note: On is the factory default setting.
Double Ring On Off	Answers calls with a double-ring pattern Note: On is the factory default setting.
Triple Ring On Off	Answers calls with a triple-ring pattern Note: On is the factory default setting.

Fax Mode (Fax Server Setup) menu

Fax Server mode sends the fax job to a fax server for transmission.

Fax Server Setup

Menu item	Description
To Format Reply Address Subject Message	Lets you enter the information using the virtual keyboard on the printer touch screen
Primary SMTP Gateway	Specifies SMTP server port information Note: 25 is the default SMTP gateway port.
Secondary SMTP Gateway	Specifies SMTP server port information Note: 25 is the default SMTP gateway port.
Image Format PDF (.pdf) XPS (.xps) TIFF (.tif)	Specifies the image type for scan to fax Note: PDF (.pdf) is the factory default setting.
Content Text Text/Photo Photograph	Specifies the type of content that will be scanned to fax Notes: <ul style="list-style-type: none"> • Text is used when the document is mostly text. • Text/Photo is the factory default setting. Text/Photo is used when the documents are mostly text or line art. • Photograph is used when the document is a high-quality photograph or inkjet print.
Fax Resolution Standard Fine Super Fine Ultra Fine	Specifies the resolution level for scan to fax Note: Standard is the factory default setting.
Darkness 1–9	Lightens or darkens the output Note: 5 factory default setting.
Orientation Portrait Landscape	Specifies the orientation of the scanned image Note: Portrait is the factory default setting.

Menu item	Description
Original Size Letter Legal Executive Folio Statement Oficio (Mexico) Universal Mixed Sizes A4 A5 A6 JIS B5 ID Card Custom Scan Size <x> Book Original Business Card 4 x 6 in. 3 x 5 in.	Specifies the paper size of the document that is being scanned Note: Letter is the US factory default setting. A4 is the international factory default setting.
Use Multi-Page TIFF On Off	Provides a choice between single-page TIFF files and multiple-page TIFF files. For a multiple-page scan to fax job, either one TIFF file is created containing all the pages, or multiple TIFF files are created with one file for each page of the job. Notes: <ul style="list-style-type: none"> • On is the factory default setting. • This menu item applies to all scan functions.
Enable Analog Receive On Off	Enables analog fax receive Note: Off is the factory default setting.

E-mail Settings menu

Menu item	Description
E-mail Server Setup Subject Message	Specifies e-mail server information Note: The message box has a limitation of 512 characters.
E-mail Server Setup Send me a copy Never appears On by default Off by default Always On	Sends a copy of the e-mail back to the creator of the e-mail Note: Never appears is the factory default setting.

Menu item	Description
E-mail Server Setup Max e-mail size 0–65535 KB	Specifies the maximum e-mail size in kilobytes Note: E-mail above the specified size is not sent.
E-mail Server Setup Size Error Message	Sends a message when an e-mail is greater than the configured size limit
E-mail Server Setup Limit destinations	Sends an e-mail only when the address contains the domain name, such as a company domain name Note: E-mail can be sent only to the specified domain.
E-mail Server Setup Web Link Setup Server Login Password Path Base file name Web Link	Defines the e-mail server path name; for example: /directory/path The following characters or symbols are invalid entries for a path name: * : ? < > .
Format PDF (.pdf) Secure PDF TIFF (.tif) JPEG (.jpg) XPS (.xps)	Specifies the format of the file Note: PDF (.pdf) is the factory default setting.
PDF Version 1.2–1.6	Sets the version of the PDF file that will be scanned to e-mail Note: 1.5 is the factory default setting.
Content Text/Photo Photograph Text	Specifies the type of content that will be scanned to e-mail Notes: <ul style="list-style-type: none"> • Text/Photo is the factory default setting. Text/Photo is used when the documents are mostly text or line art. • Photograph is used when the document is a high-quality photograph or inkjet print. • Text is used when the document is mostly text.
Color Gray Color	Specifies whether a job prints in grayscale or color Note: Color is the factory default setting.
Resolution 75 150 200 300 400 600	Specifies how many dots per inch are scanned Note: 150 dpi is the factory default setting.

Menu item	Description
Darkness 1–9	Lightens or darkens the output Note: 5 is the factory default setting.
Orientation Portrait Landscape	Specifies the orientation of the scanned image Note: Portrait is the factory default setting.
Original Size Letter Legal Executive Folio Statement Oficio (Mexico) Universal Mixed Sizes A4 A5 A6 JIS B5 ID Card Custom Scan Size <x> Book Original Business Card 3 x 5 in. 4 x 6 in.	Specifies the paper size of the document that is being scanned Note: Letter is the US factory default setting. A4 is the international factory default setting.
Sides (Duplex) Off Long edge Short edge	Specifies how the text and graphics are oriented on the page Notes: <ul style="list-style-type: none"> • Off is the factory default setting. • Long edge assumes binding along the long edge of the page (left edge for portrait orientation and top edge for landscape orientation). • Short edge assumes binding along the short edge of the page (top edge for portrait orientation and left edge for landscape orientation).
JPEG Quality Best for content 5–90	Sets the quality of a JPEG photo image in relation to file size and the quality of the image Notes: <ul style="list-style-type: none"> • “Best for content” is the factory default setting. • 5 reduces the file size, but the quality of the image is lessened. • 90 provides the best image quality, but the file size is very large. • This menu item applies to all scan functions.
Text Default 5–90	Sets the quality of the text in relation to file size and the quality of the image Note: 75 is the factory default setting.

Menu item	Description
Text/Photo Default 5–90	Sets the quality of a text/photo image in relation to file size and the quality of the image Note: 75 is the factory default setting.
Photo Default 5–90	Sets the quality of a photo image in relation to file size and the quality of the image Note: 50 is the factory default setting.
E-mail images sent as Attachment Web Link	Specifies how the images will be sent Note: Attachment is the factory default setting.
Use Multi-Page TIFF On Off	Provides a choice between single-page TIFF files and multiple-page TIFF files. For a multiple-page scan to e-mail job, either one TIFF file is created containing all the pages, or multiple TIFF files are created with one file for each page of the job. Notes: <ul style="list-style-type: none"> • On is the factory default setting. • This menu item applies to all scan functions.
Transmission Log Print log Do not print log Print only for error	Specifies whether the transmission log prints Note: “Print log” is the factory default setting.
Log Paper Source Tray <x> Manual Feeder Manual Env MP Feeder	Specifies a paper source for printing e-mail logs Note: Tray 1 is the factory default setting.
E-mail Bit Depth 8 bit 1 bit	Enables the Text/Photo mode to have smaller file sizes by using 1-bit images when Color is set to Off. Note: 8 bit is the factory default setting.
Custom Job scanning On Off	Lets you copy a document that contains mixed paper sizes into a single job Notes: <ul style="list-style-type: none"> • A printer hard disk must be installed in the printer and operating properly for this menu item to be available. • Off is the factory default setting.
Scan Preview On Off	Specifies whether a preview will appear on the display for scan jobs Notes: <ul style="list-style-type: none"> • A printer hard disk must be installed in the printer and operating properly for this menu item to be available. • Off is the factory default setting.

Menu item	Description
Allow Save as Shortcut On Off	Lets you save e-mail addresses as shortcuts Notes: <ul style="list-style-type: none"> • On is the factory default setting. • When set to Off, the Save as Shortcut button does not appear on the E-mail Destination screen.
Background Removal -4 to +4	Adjusts the amount of background visible on a scanned image Note: 0 is the factory default setting.
Color Dropout Color Dropout None Red Green Blue Default Red Threshold 0–255 Default Green Threshold 0–255 Default Blue Threshold 0–255	Specifies which color to drop during scanning, and how much to increase or decrease the dropout Notes: <ul style="list-style-type: none"> • None is the factory default setting for Color Dropout. • 128 is the factory default setting for each color threshold.
Contrast 0–5 Best for content	Specifies the contrast of the output Note: “Best for content” is the factory default setting.
Mirror Image On Off	Creates a mirror image of the original document Note: Off is the factory default setting.
Negative Image On Off	Creates a negative image of the original document Note: Off is the factory default setting.
Shadow Detail -4 to +4	Adjusts the amount of shadow detail visible on a scanned image Note: 0 is the factory default setting.
Scan edge to edge On Off	Specifies whether the original document is scanned edge-to-edge Note: Off is the factory default setting.
Sharpness 0–5	Adjusts the sharpness of a scanned image Note: 3 is the factory default setting.
Use cc:/bcc: On Off	Enables the use of the cc: and bcc: fields Note: Off is the factory default setting.

FTP Settings menu

Menu item	Description
Format PDF (.pdf) Secure PDF TIFF (.tif) JPEG (.jpg) XPS (.xps)	Specifies the format of the FTP file Note: PDF (.pdf) is the factory default setting.
PDF Version 1.2–1.6	Sets the version level of the PDF file for FTP Note: 1.5 is the factory default setting.
Content Text/Photo Photograph Text	Specifies the type of content that will be scanned to FTP Notes: <ul style="list-style-type: none"> • Text/Photo is the factory default setting. Text/Photo is used when the documents are mostly text or line art. • Photograph is used when the document is a high-quality photograph or inkjet print • Text is used when the document is mostly text.
Color Gray Color	Specifies whether a job prints in grayscale or color Note: Gray is the factory default setting.
Resolution 75 150 200 300 400 600	Specifies how many dots per inch are scanned Note: 150 dpi is the factory default setting.
Darkness 1–9	Lightens or darkens the output Note: 5 is the factory default setting.
Orientation Portrait Landscape	Specifies the orientation of the scanned image Note: Portrait is the factory default setting.

Menu item	Description
Original Size Letter Legal Executive Folio Statement Oficio (Mexico) Universal Mixed Sizes A4 A5 A6 JIS B5 ID Card Custom Scan Size <x> Book Original Business Card 3 x 5 in. 4 x 6 in.	Specifies the paper size of the document that is being scanned Note: Letter is the US factory default setting. A4 is the international factory default setting.
Sides (Duplex) Off Long edge Short edge	Specifies how the text and graphics are oriented on the page Notes: <ul style="list-style-type: none"> • Off is the factory default setting. • Long edge assumes binding along the long edge of the page (left edge for portrait orientation and top edge for landscape orientation). • Short edge assumes binding along the short edge of the page (top edge for portrait orientation and left edge for landscape orientation).
JPEG Quality Best for content 5–90	Sets the quality of a JPEG photo image in relation to file size and the quality of the image Notes: <ul style="list-style-type: none"> • “Best for content” is the factory default setting. • 5 reduces the file size, but the quality of the image is lessened. • 90 provides the best image quality, but the file size is very large. • This menu item applies to all scan functions.
Text Default 5–90	Sets the quality of the text in relation to file size and the quality of the image Note: 75 is the factory default setting.
Text/Photo Default 5–90	Sets the quality of a text/photo image in relation to file size and the quality of the image Note: 75 is the factory default setting.
Photo Default 5–90	Sets the quality of a photo image in relation to file size and the quality of the image Note: 50 is the factory default setting.

Menu item	Description
Use Multi-Page TIFF On Off	Provides a choice between single-page TIFF files and multiple-page TIFF files. For a multiple-page scan to FTP job, either one TIFF file is created containing all the pages, or multiple TIFF files are created with one file for each page of the job. Notes: <ul style="list-style-type: none"> • On is the factory default setting. • This menu item applies to all scan functions.
Transmission Log Print log Do not print log Print only for error	Specifies whether the transmission log prints Note: "Print log" is the factory default setting.
Log Paper Source Tray <x> Manual Feeder Manual Env MP Feeder	Specifies a paper source for FTP logs Note: Tray 1 is the factory default setting.
FTP bit Depth 8 bit 1 bit	Enables the Text/Photo mode to have smaller file sizes by using 1-bit images when Color is set to Off Note: 8 bit is the factory default setting.
Base File Name	Lets you enter a base file name
Custom Job Scanning On Off	Lets you scan a document that contains mixed paper sizes into a single job Notes: <ul style="list-style-type: none"> • A printer hard disk must be installed in the printer and operating properly for this menu item to be available • Off is the factory default setting.
Scan Preview On Off	Specifies whether a preview will appear on the display for scan jobs Notes: <ul style="list-style-type: none"> • A printer hard disk must be installed in the printer and operating properly for this menu item to be available • Off is the factory default setting.
Allow Save as Shortcut On Off	Enables shortcut creation for FTP addresses Note: On is the factory default setting.
Background Removal -4 to +4	Adjusts the amount of background visible on a copy Note: 0 is the factory default setting.

Menu item	Description
Color Dropout Color Dropout None Red Green Blue Default Red Threshold 0–255 Default Green Threshold 0–255 Default Blue Threshold 0–255	Specifies which color to drop during scanning, and how much to increase or decrease the dropout Notes: <ul style="list-style-type: none"> • None is the factory default setting for Color Dropout. • 128 is the factory default setting for each color threshold.
Contrast 0–5 Best for content	Specifies the contrast of the output Note: “Best for content” is the factory default setting.
Mirror Image On Off	Creates a mirror image of the original document Note: Off is the factory default setting.
Negative Image On Off	Creates a negative image of the original document Note: Off is the factory default setting.
Shadow Detail 0–4	Adjusts the amount of shadow detail visible on a scanned image Note: 0 is the factory default setting.
Scan edge to edge On Off	Specifies whether the original document is scanned edge-to-edge Note: Off is the factory default setting.
Sharpness 0–5	Adjusts the sharpness of a scanned image Note: 3 is the factory default setting.

Flash Drive menu

Scan Settings

Menu item	Description
Format PDF (.pdf) Secure PDF TIFF (.tif) JPEG (.jpg) XPS (.xps)	Specifies the format of the file
PDF Version 1.2–1.6	Sets the version of the PDF file that will be scanned to USB Note: 1.5 is the factory default setting.

Menu item	Description
Content Text/Photo Photograph Text	Specifies the type of content that will be scanned to USB Notes: <ul style="list-style-type: none"> • Text/Photo is the factory default setting. Text/Photo is used when the documents are mostly text or line art. • Photograph is used when the document is a high-quality photograph or inkjet print. • Text is used when the document is mostly text.
Color Gray Color	Specifies whether a job prints in grayscale or color Note: Gray is the factory default setting.
Resolution 75 150 200 300 400 600	Specifies how many dots per inch are scanned Note: 150 dpi is the factory default setting.
Darkness 1–9	Lightens or darkens the output Note: 5 is the factory default setting.
Orientation Portrait Landscape	Specifies the orientation of the scanned image Note: Portrait is the factory default setting.
Original Size Letter Legal Executive Folio Statement Oficio (Mexico) Universal Mixed Sizes A4 A5 A6 JIS B5 ID Card Custom Scan Size <x> Book Original Business Card 3 x 5 in. 4 x 6 in.	Specifies the paper size of the document that is being scanned Note: Letter is the US factory default setting. A4 is the international factory default setting.

Menu item	Description
Sides (Duplex) Off Long edge Short edge	Specifies how the text and graphics are oriented on the page Notes: <ul style="list-style-type: none"> • Off is the factory default setting. • Long edge assumes binding along the long edge of the page (left edge for portrait orientation and top edge for landscape orientation). • Short edge assumes binding along the short edge of the page (top edge for portrait orientation and left edge for landscape orientation).
JPEG Quality Best for content 5–90	Sets the quality of a JPEG text or text/photo image in relation to file size and the quality of the image. Notes: <ul style="list-style-type: none"> • “Best for content” is the factory default setting. • 5 reduces the file size, but the quality of the image is lessened. • 90 provides the best image quality, but the file size is very large. • This menu item applies to Text, Text/Photo, and all scan functions.
Text Default 5–90	Sets the quality of the text in relation to file size and the quality of the image Note: 75 is the factory default setting.
Text/Photo Default 5–90	Sets the quality of a text/photo image in relation to file size and the quality of the image Note: 75 is the factory default setting.
Photo Default 5–90	Sets the quality of a photo image in relation to file size and the quality of the image Note: 50 is the factory default setting.
Use Multi-Page TIFF On Off	Provides a choice between single-page TIFF files and multiple-page TIFF files. For a multiple-page scan to USB job, either one TIFF file is created containing all the pages, or multiple TIFF files are created with one file for each page of the job. Notes: <ul style="list-style-type: none"> • On is the factory default setting. • This menu item applies to all scan functions.
Scan bit Depth 8 bit 1 bit	Enables the Text/Photo mode to have smaller file sizes by using 1-bit images when Color is set to Off Note: 8 bit is the factory default setting.
Base File Name	Lets you enter a base file name
Custom Job scanning Off On	Lets you scan a document that contains mixed paper sizes into a single job Notes: <ul style="list-style-type: none"> • A printer hard disk must be installed in the printer and operating properly for this menu item to be available • Off is the factory default setting.

Menu item	Description
Scan Preview On Off	Specifies whether a preview will appear on the display for scan jobs Notes: <ul style="list-style-type: none"> • A printer hard disk must be installed in the printer and operating properly for this menu item to be available • Off is the factory default setting.
Background Removal -4 to +4	Adjusts the amount of background visible on a copy Note: 0 is the factory default setting.
Color Dropout Color Dropout None Red Green Blue Default Red Threshold 0–255 Default Green Threshold 0–255 Default Blue Threshold 0–255	Specifies which color to drop during scanning, and how much to increase or decrease the dropout Notes: <ul style="list-style-type: none"> • None is the factory default setting for Color Dropout. • 128 is the factory default setting for each color threshold.
Contrast 0–5 Best for content	Specifies the contrast of the output Note: “Best for content” is the factory default setting.
Mirror Image On Off	Creates a mirror image of the original document Note: Off is the factory default setting.
Negative Image On Off	Creates a negative image of the original document Note: Off is the factory default setting.
Shadow Detail 0–4	Adjusts the amount of shadow detail visible on a scanned image Note: 0 is the factory default setting.
Scan edge to edge On Off	Specifies whether the original document is scanned edge-to-edge Note: Off is the factory default setting.
Sharpness 0–5	Adjusts the sharpness of a scanned image Note: 3 is the factory default setting.

Print Settings

Menu item	Description
Copies	Specifies the number of copies to print

Menu item	Description
Paper Source Tray <x> MP Feeder Manual Paper Manual Envelope	Specifies the paper source selected to supply paper for the printer to print from the flash drive
Collate Off (1,1,1,2,2,2) On (1,2,1,2,1,2)	Stacks the pages of a print job in sequence when printing multiple copies Notes: <ul style="list-style-type: none"> • Off is the factory default setting. No pages will be collated. • The On setting stacks the print job sequentially.
Sides (Duplex) 1 sided 2 sided	Enables duplex printing (two-sided printing)
Duplex Binding Long Edge Short Edge	Defines the way duplexed pages are bound and how the printing on the back of the page is oriented in relation to the printing on the front of the page Notes: <ul style="list-style-type: none"> • Long Edge is the factory default setting. • Long Edge specifies that binding be placed on the left edge of portrait pages and the top edge of landscape pages. • Short Edge specifies that binding be placed on the top edge of portrait pages and the left edge of landscape pages.
Orientation Auto Portrait Landscape	Specifies the orientation of the print job Note: Auto is the factory default setting.
N-up (pages/side) Off 2 Up 3 Up 4 Up 6 Up 9 Up 12 Up 16 Up	Specifies that multiple-page images be printed on one side of a sheet of paper. This is also referred to as Paper Saver. Notes: <ul style="list-style-type: none"> • Off is the factory default setting. • The number selected is the number of page images that will print per side.
N-up Border None Solid	Prints a border around each page image when using N-up Note: None is the factory default setting.
N-up Ordering Horizontal Reverse Horizontal Reverse Vertical Vertical	Specifies the positioning of multiple-page images when using N-up Notes: <ul style="list-style-type: none"> • Horizontal is the factory default setting. • Positioning depends on the number of images and whether the images are in portrait or landscape orientation.

Menu item	Description
Separator Sheets None Between Copies Between Jobs Between Pages	Places a sheet of paper between pages, copies, or jobs based on the value selected Note: None is the factory default setting.
Separator Sheet Source Tray <x> Manual Feeder	Specifies a paper source
Blank Pages Do Not Print Print	Specifies whether blank pages are inserted in a print job Note: Do Not Print is the factory default setting.

Print Settings

Setup menu

Menu item	Description
Printer Language PCL Emulation PS Emulation	Sets the default printer language Notes: <ul style="list-style-type: none"> • PCL emulation uses a PCL interpreter for processing print jobs. PostScript emulation uses a PS interpreter for processing print jobs. • PCL is the factory default printer language. • Setting a printer language as the default does not prevent a software program from sending print jobs that use another printer language.
Job Waiting On Off	Specifies that print jobs be removed from the print queue if they require unavailable printer options or custom settings. They are stored in a separate print queue, so other jobs print normally. When the missing information and/or options are obtained, the stored jobs print. Notes: <ul style="list-style-type: none"> • Off is the factory default setting. • This menu appears only if a non-Read Only printer hard disk is installed. This requirement ensures that stored jobs are not deleted if the printer loses power.

Menu item	Description
Print Area Normal Whole Page	Sets the logical and physical printable area Notes: <ul style="list-style-type: none"> • This menu does not appear if Edge to Edge is enabled in the printer Setup menu. • Normal is the factory default setting. When attempting to print data in the non-printable area defined by the Normal setting, the printer clips the image at the boundary. • The Whole Page setting allows the image to be moved into the non-printable area defined by the Normal setting, but the printer will clip the image at the Normal setting boundary. • The Whole Page setting only affects pages printed using a PCL 5e interpreter. This setting has no effect on pages printed using the PCL XL or PostScript interpreter.
Download Target RAM Flash Disk	Sets the storage location for downloads Notes: <ul style="list-style-type: none"> • RAM is the factory default setting. • Storing downloads in flash memory or on a printer hard disk places them in permanent storage. Downloads remain in flash memory or on the printer hard disk even when the printer is turned off. • Storing downloads in RAM is temporary. • This menu appears only if a flash and/or disk option is installed.
Job Accounting On Off	Specifies whether the printer stores statistical information about the most recent print jobs on the hard disk Notes: <ul style="list-style-type: none"> • Off is the factory default setting. Off means the printer does not store job statistics. • The statistics include a record of print errors, the print time, the job size in bytes, the requested paper size and type, the total number of printed pages, and the total number of copies requested. • Job Accounting is available only when a printer hard disk is installed and working properly. It should not be Read/Write or Write protected. Job Buffer Size should not be set to 100%. • Changing this setting from the printer control panel and then exiting the menus causes the printer to reset. The menu selection is updated.

Menu item	Description
Resource Save On Off	<p>Specifies how the printer handles temporary downloads, such as fonts and macros stored in RAM, when the printer receives a job that requires more memory than is available</p> <p>Notes:</p> <ul style="list-style-type: none"> • Off is the factory default setting. Off sets the printer to retain the downloads only until memory is needed. Downloads are deleted in order to process print jobs. • The On setting retains the downloads during language changes and printer resets. If the printer runs out of memory, 38 Memory Full appears, and downloads are not deleted.
Print All Order Alphabetically Newest First Oldest First	<p>Specifies the order in which held and confidential jobs are printed when Print All is selected</p> <p>Notes:</p> <ul style="list-style-type: none"> • Alphabetically is the factory default setting. • Print jobs always appear in alphabetical order on the printer control panel.

Finishing menu

Menu item	Description
Sides (Duplex) 2 sided 1 sided	<p>Specifies whether duplex (2-sided) printing is set as the default for all print jobs</p> <p>Notes:</p> <ul style="list-style-type: none"> • 1 sided is the factory default setting. • To set 2-sided printing from the software program: for Windows users, click File > Print, and then click Properties, Preferences, Options, or Setup; for Macintosh users, choose File > Print, and then adjust the settings from the Print dialog and pop-up menus.
Duplex Binding Long Edge Short Edge	<p>Defines the way duplexed pages are bound and how the printing on the back of the page is oriented in relation to the printing on the front of the page</p> <p>Notes:</p> <ul style="list-style-type: none"> • Long Edge is the factory default setting. • Long Edge specifies that binding be placed on the left edge of portrait pages and the top edge of landscape pages. • Short Edge specifies that binding be placed on the top edge of portrait pages and the left edge of landscape pages.
Copies 1–999	<p>Specifies a default number of copies for each print job</p> <p>Note: 1 is the factory default setting.</p>
Blank Pages Do Not Print Print	<p>Specifies whether blank pages are inserted in a print job</p> <p>Note: Do Not Print is the factory default setting.</p>

Menu item	Description
Collate Off (1,1,1,2,2,2) On (1,2,1,2,1,2)	Stacks the pages of a print job in sequence when printing multiple copies Notes: <ul style="list-style-type: none"> • On is the factory default setting. • The On setting stacks the print job sequentially. • Both settings print the entire job the number of times specified by the Copies menu setting.
Separator Sheets None Between Copies Between Jobs Between Pages	Specifies whether blank separator sheets are inserted Notes: <ul style="list-style-type: none"> • None is the factory default setting. • Between Copies inserts a blank sheet between each copy of a print job if Collation is set to On. If Collation is set to Off, a blank page is inserted between each set of printed pages, such as after all page 1's and after all page 2's. • Between Jobs inserts a blank sheet between print jobs. • Between Pages inserts a blank sheet between each page of the print job. This setting is useful when printing transparencies or inserting blank pages in a document for notes.
Separator Source Tray <x> Multi-Purpose Feeder	Specifies the paper source for separator sheets Notes: <ul style="list-style-type: none"> • Tray 1 (standard tray) is the factory default setting. • From the Paper menu, Configure MP must be set to Cassette in order for Multi-Purpose Feeder to appear as a menu setting.
N-up (pages-side) Off 2-Up 3-Up 4-Up 6-Up 9-Up 12-Up 16-Up	Specifies that multiple-page images be printed on one side of a sheet of paper Notes: <ul style="list-style-type: none"> • Off is the factory default setting. • The number selected is the number of page images that will print per side.
N-up Ordering Horizontal Reverse Horizontal Reverse Vertical Vertical	Specifies the positioning of multiple-page images when using N-up (pages-sides) Notes: <ul style="list-style-type: none"> • Horizontal is the factory default setting. • Positioning depends on the number of images and whether the images are in portrait or landscape orientation.
Orientation Auto Landscape Portrait	Specifies the orientation of a multiple-page sheet Note: Auto is the factory default setting. The printer chooses between portrait and landscape.

Menu item	Description
N-up Border None Solid	Prints a border around each page image when using N-up (pages-sides) Note: None is the factory default setting.

Quality menu

Menu item	Description
Print Resolution 300 dpi 600 dpi 1200 dpi 1200 Image Q 2400 Image Q	Specifies the printed output resolution Note: 600 dpi is the factory default setting. The printer driver default is 1200 IQ.
Pixel Boost Off Fonts Horizontally Vertically Both Directions	Enhances the printed quality of small fonts and graphics Notes: <ul style="list-style-type: none"> • Off is the factory default setting. • Fonts applies this setting only to text. • Horizontally darkens horizontal lines of text and images. • Vertically darkens vertical lines of text and images. • Both Directions darkens horizontal and vertical lines on text and images.
Toner Darkness 1–10	Lightens or darkens the printed output Notes: <ul style="list-style-type: none"> • 8 is the factory default setting. • Selecting a smaller number can help conserve toner.
Enhance Fine Lines On Off	Enables a print mode preferable for files such as architectural drawings, maps, electrical circuit diagrams, and flow charts Notes: <ul style="list-style-type: none"> • Off is the factory default setting. • To set Enhance Fine Lines using the Embedded Web Server, type the network printer IP address in a browser window.
Gray Correction Auto Off	Adjusts the gray value of printed output Note: Auto is the factory default setting.
Brightness -6 to +6	Adjusts or darkens printed output and conserves toner Notes: <ul style="list-style-type: none"> • 0 is the factory default setting. • A negative value will darken text, images, and graphics. A positive value will lighten them and conserve toner.

Menu item	Description
Contrast 0–5	Adjusts the degree of difference between levels of gray in printed output Notes: <ul style="list-style-type: none"> • 0 is the factory default setting. • Higher settings show more difference between levels of gray.

Utilities menu

Menu item	Description
Remove Held Jobs Confidential Held Not Restored All	Removes confidential and held jobs from the printer hard disk Notes: <ul style="list-style-type: none"> • Selecting a setting affects only print jobs that are resident in the printer. Bookmarks, jobs on flash drives, and other types of held jobs are not affected. • Selecting Not Restored removes all Print and Hold jobs that were <i>not</i> restored from the disk.
Format Flash Yes No	Formats the flash memory. Flash memory refers to the memory added by installing a flash memory option card in the printer. Warning—Potential Damage: Do not turn off the printer while the flash memory is formatting. Notes: <ul style="list-style-type: none"> • A flash memory option card must be installed in the printer and operating properly for this menu item to be available. The flash memory option card must not be Read/Write or Write protected. • Selecting Yes deletes all data stored in flash memory. • No cancels the format request.
Delete Downloads on Disk Delete Now Do Not Delete	Removes downloads from the printer hard disk, including all held Jobs, buffered jobs, and parked jobs. Job accounting information is not affected. Note: Delete Now is the default setting.
Job Acct Stat Print Clear	Prints a list of all stored job statistics or deletes the information from the printer hard disk Notes: <ul style="list-style-type: none"> • A printer hard disk must be installed in the printer and operating properly for this menu item to be available. • Selecting Print prints a list of statistics. • Clear deletes all job statistics stored on the printer hard disk. • The Clear selection will not appear if Job Accounting is set to MarkTrack™ using NPA.

Menu item	Description
Hex Trace Activate	Assists in isolating the source of a print job problem Notes: <ul style="list-style-type: none"> • When Activate is selected, all data sent to the printer is printed in hexadecimal and character representation and control codes are not executed. • To exit or deactivate Hex Trace, turn the printer off or reset the printer.
Coverage Estimator Off On	Provides an estimate of the percentage coverage of black on a page. The estimate is printed on a separate page at the end of each print job. Note: Off is the factory default setting.

PDF menu

Menu item	Description
Scale to Fit Yes No	Scales page content to fit the selected paper size Note: No is the factory default setting.
Annotations Do Not Print Print	Prints annotations in a PDF Note: Do Not Print is the factory default setting.

PostScript menu

Menu item	Description
Print PS Error On Off	Prints a page containing the PostScript error Note: Off is the factory default setting.
Font Priority Resident Flash/Disk	Establishes the font search order Notes: <ul style="list-style-type: none"> • Resident is the factory default setting. • A formatted flash memory option card or printer hard disk must be installed in the printer and operating properly for this menu item to be available. • The flash memory option or printer hard disk cannot be Read/Write, Write, or password protected. • Job Buffer Size must not be set to 100%.

PCL Emul menu

Menu item	Description
Font Source Resident Disk Download Flash All	Specifies the set of fonts used by the Font Name menu item Notes: <ul style="list-style-type: none"> • Resident is the factory default setting. It shows the factory default set of fonts downloaded into printer RAM. • Flash and Disk settings appear only if applicable and show all fonts resident in that option. • Flash and Disk options must be properly formatted and cannot be Read/Write, Write, or password protected. • Download appears only if applicable and shows all the fonts downloaded into printer RAM. • All shows all fonts available to any option.
Font Name <list of available fonts>	Identifies a specific font and the option where it is stored Notes: <ul style="list-style-type: none"> • Courier 10 is the factory default setting. • The font source abbreviation is R for Resident, F for Flash, K for Disk, and D for download.
Symbol Set 10U PC-8 12U PC-850	Specifies the symbol set for each font name Notes: <ul style="list-style-type: none"> • 10U PC-8 is the US factory default setting. • 12U PC-850 is the international factory default setting. • A symbol set is a set of alphabetic and numeric characters, punctuation, and special symbols. Symbol sets support the different languages or specific programs such as math symbols for scientific text. Only the supported symbol sets are shown.
PCL Emulation Settings Pitch 0.08–100	Specifies the font pitch for scalable monospaced fonts Notes: <ul style="list-style-type: none"> • 10 is the factory default setting. • Pitch refers to the number of fixed-space characters per inch (cpi). • Pitch can be increased or decreased in 0.01-cpi increments. • For nonscalable monospaced fonts, the pitch appears on the display but cannot be changed.
PCL Emulation Settings Orientation Portrait Landscape	Specifies the orientation of text and graphics on the page Notes: <ul style="list-style-type: none"> • Portrait is the factory default setting. • Portrait prints text and graphics parallel to the short edge of the page. • Landscape prints text and graphics parallel to the long edge of the page.

Menu item	Description
PCL Emulation Settings Lines per Page 1–255	Specifies the number of lines that print on each page Notes: <ul style="list-style-type: none"> • 60 is the US factory default setting. 64 is the international default setting. • The printer sets the amount of space between each line based on the Lines per Page, Paper Size, and Orientation settings. Select the desired Paper Size and Orientation <i>before</i> setting Lines per Page.
PCL Emulation Settings A4 Width 198 mm 203 mm	Sets the printer to print on A4-size paper Notes: <ul style="list-style-type: none"> • 198 mm is the factory default setting. • The 203-mm setting sets the width of the page to allow the printing of eighty 10-pitch characters.
PCL Emulation Settings Auto CR after LF On Off	Specifies whether the printer automatically performs a carriage return after a line feed control command Note: Off is the factory default setting.
PCL Emulation Settings Auto LF after CR On Off	Specifies whether the printer automatically performs a line feed after a carriage return control command Note: Off is the factory default setting.
Tray Renumber Assign MP Feeder Off None 0–199 Assign Tray <x> Off None 0–199 Assign Manual Paper Off None 0–199 Assign Man Env Off None 0–199	Configures the printer to work with printer software or programs that use different source assignments for trays, drawers, and feeders Notes: <ul style="list-style-type: none"> • Off is the factory default setting. • None is not an available selection. It appears only when it is selected by the PCL 5 interpreter. • None ignores the Select Paper Feed command. • 0–199 allows a custom setting to be assigned.

Menu item	Description
<p>Tray Renumber</p> <p>View Factory Def</p> <p>MPF Default = 8</p> <p>T1 Default = 1</p> <p>T2 Default = 4</p> <p>T3 Default = 5</p> <p>T4 Default = 20</p> <p>T5 Default = 21</p> <p>Env Default = 6</p> <p>MPaper Default = 2</p> <p>MEnv Default = 3</p>	<p>Lets you view the factory default setting assigned to each tray, drawer, or feeder, even if it has not been installed</p>
<p>Tray Renumber</p> <p>Restore Defaults</p> <p>Yes</p> <p>No</p>	<p>Returns all tray, drawer, and feeder assignments to the factory default settings</p>

HTML menu

Menu item		Description
<p>Font Name</p> <p>Albertus MT</p> <p>Antique Olive</p> <p>Apple Chancery</p> <p>Arial MT</p> <p>Avant Garde</p> <p>Bodoni</p> <p>Bookman</p> <p>Chicago</p> <p>Clarendon</p> <p>Cooper Black</p> <p>Copperplate</p> <p>Coronet</p> <p>Courier</p> <p>Eurostile</p> <p>Garamond</p> <p>Geneva</p> <p>Gill Sans</p> <p>Goudy</p> <p>Helvetica</p> <p>Hoefler Text</p>	<p>Intl CG Times</p> <p>Intl Courier</p> <p>Intl Univers</p> <p>Joanna MT</p> <p>Letter Gothic</p> <p>Lubalin Gothic</p> <p>Marigold</p> <p>MonaLisa Recut</p> <p>Monaco</p> <p>New CenturySbk</p> <p>New York</p> <p>Optima</p> <p>Oxford</p> <p>Palatino</p> <p>StempelGaramond</p> <p>Taffy</p> <p>Times</p> <p>TimesNewRoman</p> <p>Univers</p> <p>Zapf Chancery</p>	<p>Sets the default font for HTML documents</p> <p>Notes:</p> <ul style="list-style-type: none"> • The Times font will be used in HTML documents that do not specify a font. • The following fonts appear only if the appropriate DBCS font card is installed: HG-GothicB, MSung-Light, MD_DotumChe, and MingMT-Light.

Menu item	Description
Font Size 1–255 pt	Sets the default font size for HTML documents Notes: <ul style="list-style-type: none"> • 12 pt is the factory default setting. • Font size can be increased in 1-point increments.
Scale 1–400%	Scales the default font for HTML documents Notes: <ul style="list-style-type: none"> • 100% is the factory default setting. • Scaling can be increased in 1% increments.
Orientation Portrait Landscape	Sets the page orientation for HTML documents Note: Portrait is the factory default setting.
Margin Size 8–255 mm	Sets the page margin for HTML documents Notes: <ul style="list-style-type: none"> • 19 mm is the factory default setting. • Margin size can be increased in 1-mm increments.
Backgrounds Do Not Print Print	Specifies whether to print backgrounds on HTML documents Note: Print is the factory default setting.

Image menu

Menu item	Description
Auto Fit On Off	Selects the optimal paper size, scaling, and orientation Notes: <ul style="list-style-type: none"> • On is the factory default setting. • The On setting overrides scaling and orientation settings for some images.
Invert On Off	Inverts bi-tonal monochrome images Notes: <ul style="list-style-type: none"> • Off is the factory default setting. • The font size can be increased in 1-point increments. • This setting does not apply to GIF or JPEG images.
Scaling Anchor Top Left Best Fit Anchor Center Fit Height/Width Fit Height Fit Width	Scales the image to fit the selected paper size Notes: <ul style="list-style-type: none"> • Best Fit is the factory default setting. • When Auto Fit is set to On, Scaling is automatically set to Best Fit.

Menu item	Description
Orientation Portrait Landscape Rev Portrait Rev Landscape	Sets the image orientation Note: Portrait is the factory default setting.

XPS menu

Menu item	Description
Print Error Pages Off On	Prints a page containing information on errors, including XML markup errors Note: Off is the factory default setting.

Help menu

The Help menu consists of Help pages that are stored in the printer as PDFs. They contain reference information about using the printer and performing tasks. You may select to print each one individually, or select **Print all guides** to print all of them at one time.

English, French, German, and Spanish translations are stored in the printer. Other translations are available on the *Software and Documentation CD*.

Menu item	Description
Print all guides	Prints all the guides
Copy guide	Provides information about making copies and changing settings
E-mail guide	Provides information about sending e-mails using addresses, shortcut numbers, or the address book, and changing settings
Fax guide	Provides information about sending faxes using fax numbers, shortcut numbers, or the address book, and changing settings
FTP guide	Provides information about scanning documents directly to an FTP server using an FTP address, shortcut numbers, or the address book, and changing settings
Information guide	Provides help in locating additional information
Print defects guide	Provides help in resolving repeating defects in copies or prints
Supplies guide	Provides part numbers for ordering supplies

Maintaining the printer

Periodically, certain tasks are required to maintain optimum print quality.

Cleaning the exterior of the printer

- 1 Make sure that the printer is turned off and unplugged from the wall outlet.

CAUTION—SHOCK HAZARD: To avoid the risk of electric shock when cleaning the exterior of the printer, unplug the power cord from the wall outlet and disconnect all cables to the printer before proceeding.

- 2 Remove all paper from the printer.
- 3 Dampen a clean, lint-free cloth with water.

Warning—Potential Damage: Do not use household cleaners or detergents, as they may damage the finish of the printer.

- 4 Wipe only the outside of the printer.

Warning—Potential Damage: Using a damp cloth to clean the interior may cause damage to your printer.

- 5 Make sure all areas of the printer are dry before beginning a new print job.

Cleaning the scanner glass

If you encounter print quality problems, such as streaks on copied or scanned images, clean the areas shown.

- 1 Slightly dampen a soft, lint-free cloth or paper towel with water.
- 2 Open the scanner cover.

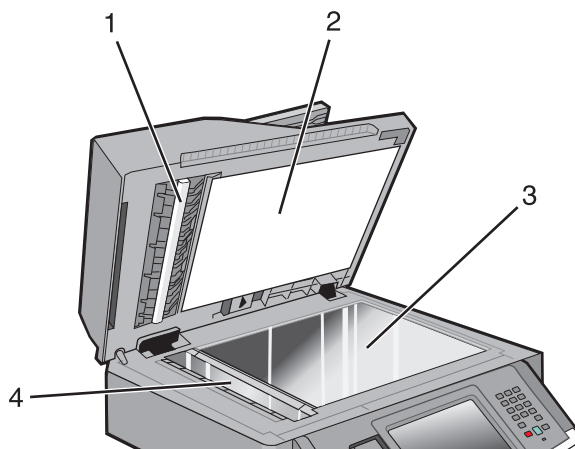

1	White underside of the ADF cover
2	White underside of the scanner cover
3	Scanner glass
4	ADF glass

- 3 Wipe the areas shown and let them dry.
- 4 Close the scanner cover.

Cleaning the ADF separator rollers

After you have copied over 50,000 copies using the ADF, clean the ADF separator rollers.

- 1 Open the ADF cover.

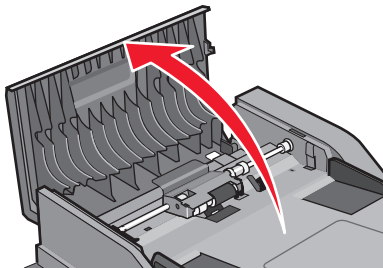

- 2 Unlock the separator roll.

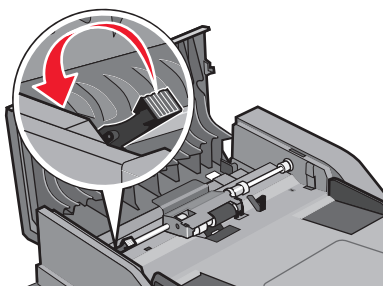

- 3 Remove the separator roll.

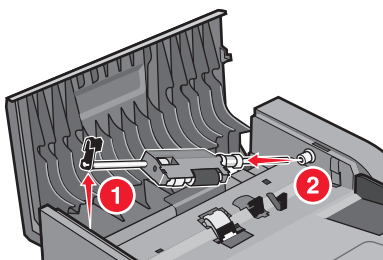

- 4 Use a clean, lint-free cloth dampened with water to wipe the separator rollers.

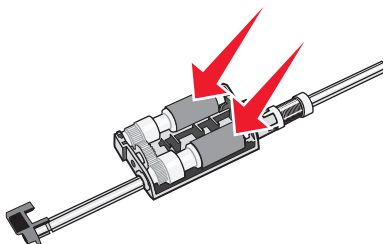

- 5 Reinstall the separator roll.

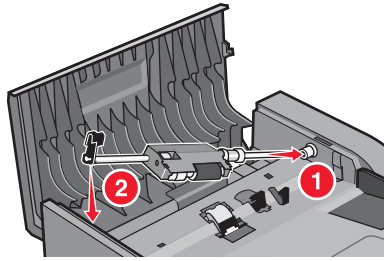

- 6 Lock the separator roll.

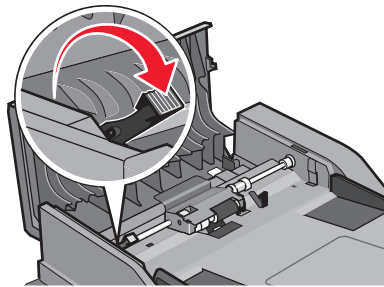

- 7 Close the ADF cover.

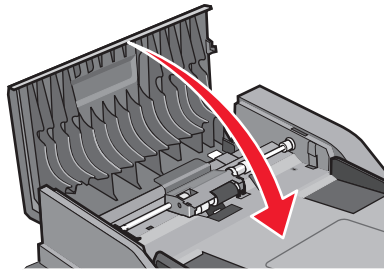

Adjusting scanner registration

Scanner Registration is a process to align the scan area with the paper location. To manually adjust the scanner registration:

- 1 Turn the printer off.
- 2 Clean the scanner glass and backing material.
- 3 Hold down **2** ABC and **6** MNO while turning the printer on.
- 4 Release the buttons when the screen with the progress bar appears.
The printer performs a power-on sequence, and then the Configuration menu appears.
- 5 Touch the down arrow until **Scanner Manual Registration** appears.
- 6 Touch **Scanner Manual Registration**.
- 7 Touch **Print Quick Test** to print a registration page.
- 8 Choose the section of the scanner to align.

To align the scanner glass (flatbed):

- a Place the Quick Test page facedown on the scanner glass.

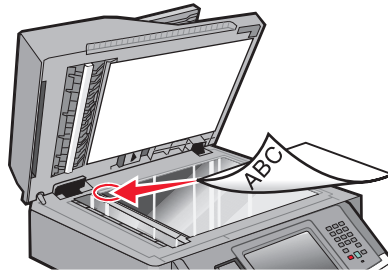

- b Touch **Copy Quick Test**.

The scanner prints a copy of the Quick Test page.

- c Touch **Flatbed**.

- d Use the copy of the Quick Test page to adjust the Left Margin and Top Margin settings.

- e Touch **Submit**.

- f Touch **Copy Quick Test** and compare the new copy to the original.

Repeat the flatbed alignment steps until the position on the page of the Quick Test copy closely matches the original.

To align the ADF:

- a Do one of the following:

- To align the ADF front: place the Quick Test page faceup, short edge first into the ADF.
- To align the ADF back: place the Quick Test page facedown, short edge first into the ADF.

- b Touch **Copy Quick Test**.

The scanner prints a copy of the Quick Test page.

- c Touch **ADF Front** or **ADF Back**.

- d Use the copy of the Quick Test page to adjust the Horizontal Adjust and Top Margin settings.

- e Touch **Submit**.

- f Touch **Copy Quick Test** and compare the new copy to the original.

Repeat the ADF alignment steps until the position on the page of the Quick Test copy closely matches the original.

- 9 Touch **Back**.

- 10 Touch **Exit Configuration**.

Storing supplies

Choose a cool, clean storage area for the printer supplies. Store supplies right side up in their original packing until you are ready to use them.

Do not expose supplies to:

- Direct sunlight
- Temperatures above 35°C (95°F)
- High humidity above 80%
- Salty air

- Corrosive gases
- Heavy dust

Checking the status of supplies

A message appears on the display when a replacement supply item is needed or when maintenance is required.

Checking the status of supplies from the printer control panel

1 Make sure the printer is on and **Ready** appears.

2 On the home screen, touch **Status/Supplies**.

Note: If **Status/Supplies** is not on the home screen, then print a menu settings page to review the status of the supplies.

3 Touch **View supplies**.

The View supplies screen appears, showing a summary of supply levels.

Note: The Black Cartridge gauge is only an estimate of how much toner is left in your cartridge.

Checking the status of supplies from a network computer

Note: The computer must be connected to the same network as the printer.

1 Type the printer IP address into the address field of your Web browser.

Note: If you do not know the IP address of the printer, print a network setup page and locate the IP address in the TCP/IP section.

2 Click **Device Status**. The Device Status page appears, displaying a summary of supply levels.

Ordering supplies

To order supplies in the U.S., contact Lexmark at 1-800-539-6275 for information about Lexmark authorized supplies dealers in your area. In other countries or regions, visit the Lexmark Web Site at www.lexmark.com or contact the place where you purchased the printer.

Warning—Potential Damage: Damage caused by the use of a supply or replacement item not produced by the manufacturer of this printer is not covered under warranty. Degraded print quality may result from using supplies or replacement items not produced by the manufacturer of this printer.

Note: All life estimates for printer supplies assume printing on letter- or A4-size plain paper.

Ordering toner cartridges

When **88 Cartridge low** appears or when the print becomes faded:

- 1 Remove the toner cartridge.
- 2 Firmly shake the cartridge side-to-side and front-to-back several times to redistribute toner.

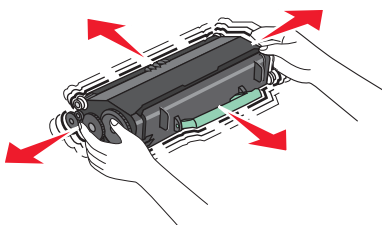

- 3 Reinsert the cartridge and continue printing.

Note: Repeat this procedure multiple times until the print remains faded, and then replace the cartridge.

Recommended toner cartridges and part numbers

Part name	Lexmark Return Program Cartridge	Regular cartridge
Toner Cartridge	X463A11G	X463A21G
High Yield Toner Cartridge	X463H11G	X463H21G
Extra High Yield Toner Cartridge	X463X11G	X463X21G

Ordering a photoconductor kit

Depending on your printer model, the printer issues a message or a light sequence to let you know the photoconductor kit is near its end of life. At this time, order a photoconductor kit. You can also see the status of the photoconductor kit by printing a network setup page.

Part name	Part number
Photoconductor kit	E260X22G

Ordering ADF replacement parts

Order ADF replacement parts if you experience problems with paper double-feeding or failing to feed through the Automatic Document Feeder.

Part name	Part number
ADF input tray	40X5470
ADF separator pad	40X5472
ADF separator roll	40X5471

Moving the printer to another location

Warning—Potential Damage: Damage to the printer caused by improper moving is not covered by the printer warranty.

CAUTION—POTENTIAL INJURY: The printer weight is greater than 18 kg (40 lb) and requires two or more trained personnel to move it safely.

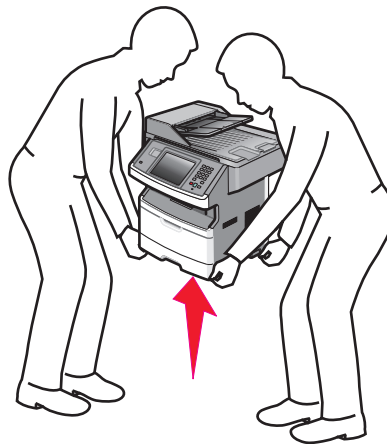

CAUTION—POTENTIAL INJURY: Follow these guidelines to avoid personal injury or printer damage:

- Turn the printer off using the power switch, and then unplug the power cord from the wall outlet.
- Disconnect all cords and cables from the printer before moving it.
- Use the handholds located on both sides of the printer to lift it.
- Make sure your fingers are not under the printer when you set it down.
- Before setting up the printer, make sure there is adequate clearance around it. For more information, see “Selecting a location for the printer” on page 19.

The printer and options can be safely moved to another location by following these precautions:

- Any cart used to move the printer must be able to support its weight and have a large enough surface to support the full footprint of the printer.
- Keep the printer in an upright position.
- Avoid severe jarring movements.

Shipping the printer

When shipping the printer, use the original packaging or call the place of purchase for a relocation kit.

Administrative support

Finding advanced networking and administrator information

This chapter covers basic administrative support tasks. For more advanced system support tasks, see the *Networking Guide* on the *Software and Documentation* CD and the *Embedded Web Server Administrator's Guide* on the Lexmark Web site at www.lexmark.com.

Using the Embedded Web Server

If the printer is installed on a network, then the Embedded Web Server is available for a range of functions, including:

- Viewing a virtual display of the printer control panel
- Checking the status of the printer supplies
- Configuring printer settings
- Configuring network settings
- Viewing reports

To access the Embedded Web Server, type the printer IP address into the address field of your Web browser.

Notes:

- If you do not know the IP address of the printer, then print a network setup page and locate the IP address in the TCP/IP section.
- For more information, see the *Networking Guide* on the *Software and Documentation* CD and the *Embedded Web Server Administrator's Guide* on the Lexmark Web site at www.lexmark.com/publications.

Checking the device status

From the Device Status page of the Embedded Web Server, it is possible to see paper tray settings, the level of toner in the toner cartridge, the percentage of life remaining in the photoconductor kit, and capacity measurements of certain printer parts. To view the device status:

- 1 Type the printer IP address in the address field of your Web browser.

Note: If you do not know the IP address of the printer, then print a network setup page and locate the IP address in the TCP/IP section.

- 2 Click **Device Status**.

Setting up e-mail alerts

You can have the printer send you an e-mail when the supplies are getting low or when the paper needs to be changed, added, or unjammed.

To set up e-mail alerts:

- 1 Type the printer IP address into the address field of your Web browser.
Note: If you do not know the IP address of the printer, then print a network setup page and locate the IP address in the TCP/IP section.
- 2 Click **Settings**.
- 3 Under Other Settings, click **E-mail Alert Setup**.
- 4 Select the items for notification, and type in the e-mail addresses.
- 5 Click **Submit**.

Note: See your system support person to set up the e-mail server.

Viewing reports

You can view some reports from the Embedded Web Server. These reports are useful for assessing the status of the printer, the network, and supplies.



To view reports from a network printer:

- 1 Type the printer IP address into the address field of your Web browser.
Note: If you do not know the IP address of the printer, then print a network setup page and locate the IP address in the TCP/IP section.
- 2 Click **Reports**, and then click the type of report you want to view.

Restoring the factory default settings

If you want to retain a list of the current menu settings for reference, then print a menu settings page before you restore the factory default settings. For more information, see “Printing a menu settings page” on page 51.

Warning—Potential Damage: Restoring factory defaults returns most printer settings to the original factory default setting. Exceptions include the display language, custom sizes and messages, and Network/Port menu settings. All downloads stored in RAM are deleted. Downloads stored in flash memory or on a printer hard disk are not affected.

- 1 Make sure the printer is on and **Ready** appears.
- 2 On the home screen, touch .
- 3 Touch **Settings**.
- 4 Touch **General Settings**.
- 5 Touch the down arrow until **Factory Defaults** appears.
- 6 Touch the left or right arrow until **Restore Now** appears.
- 7 Touch **Submit**.
- 8 Touch .

Clearing jams

Clearing jams

By carefully selecting paper and loading it properly, you can avoid most jams. If jams do occur, follow the steps outlined in this section.

To clear a jam message and resume printing, clear the entire paper path, and then touch **Continue**. If Jam Recovery is set to On, then the printer prints a new copy of the page that jammed. If Jam Recovery is set to Auto, then the printer reprints the jammed page if enough printer memory is available.

Understanding jam messages and locations

Note: To resolve any message, all paper or specialty media must be cleared from the entire paper path.

Open doors and remove trays to access jam areas. The following illustration shows possible jam areas:

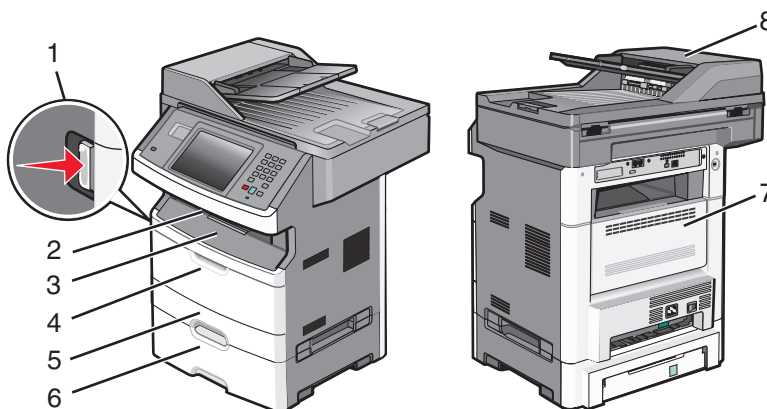

Access point	Description
1	Push the button to open the front door. Inside are the toner cartridge and photoconductor kit.
2	Standard exit bin
3	Front door
4	Manual or multipurpose feeder door
5	Standard 250-sheet tray (Tray 1)
6	Optional 250- or 550-sheet tray (Tray 2)
7	Rear door
8	Automatic Document Feeder (ADF)

Jam message numbers and how to access each jam

Jam number	To access the jam
200-201	Try one or more of the following: <ul style="list-style-type: none"> • Remove Tray 1. • Open the front door, and then remove the photoconductor kit.
202	Open the front door, and then open the rear door.
231	Open the front door, and then open the rear door.
233	Remove Tray 1, and then depress the lever. Note: For alternative access to the jam, open the front door, and then open the rear door.
234	Try one or more of the following: <ul style="list-style-type: none"> • Open the front door, and then open the rear door. • Remove Tray 1, and then depress the lever.
235	Remove the jam from the standard exit bin.
240-249	Remove Tray 2.
250	Open the multipurpose feeder door.
251	Open the multipurpose feeder door.
290-295	Try one or more of the following: <ul style="list-style-type: none"> • Open the ADF cover, and then remove the separator roll. • Open the scanner cover. • Remove the ADF tray.

200 and 201 paper jams

 **CAUTION—HOT SURFACE:** The inside of the printer might be hot. To reduce the risk of injury from a hot component, allow the surface to cool before touching.

- 1 Pull the tray completely out.

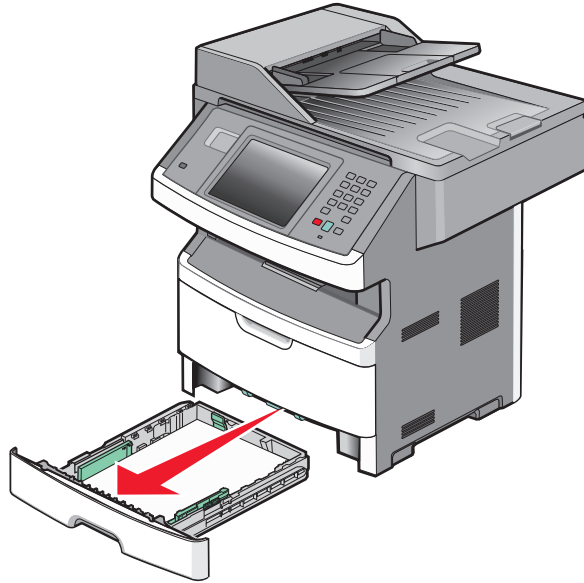

- 2 Remove the jam if you see it here.

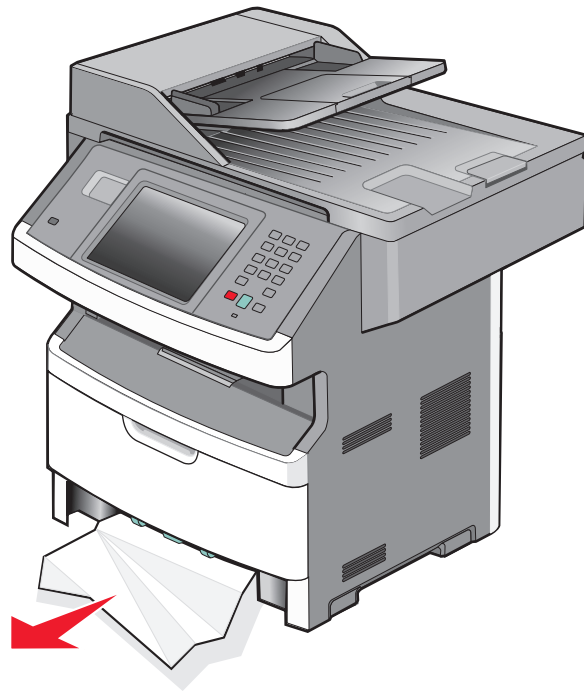

3 If you do not see the jam, open the front door, and then remove the photoconductor kit and toner cartridge.

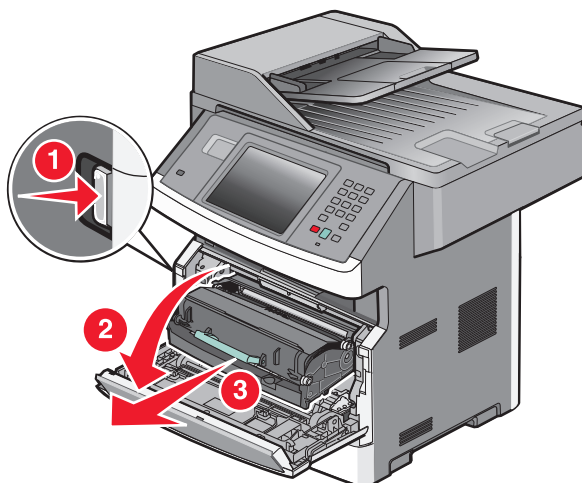

4 Lift the flap at the front of the printer, and then remove any jammed sheets.

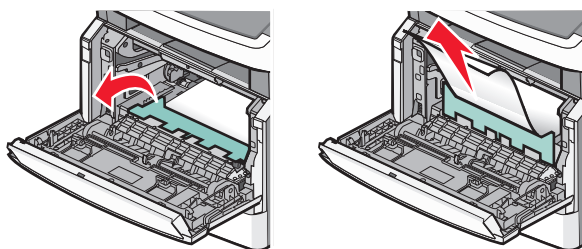

5 If you do not see any jammed sheets, open the rear door.

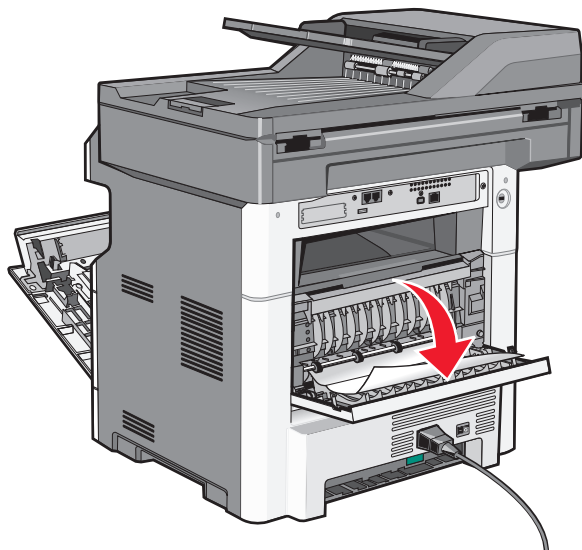

- 6 Remove the jam.

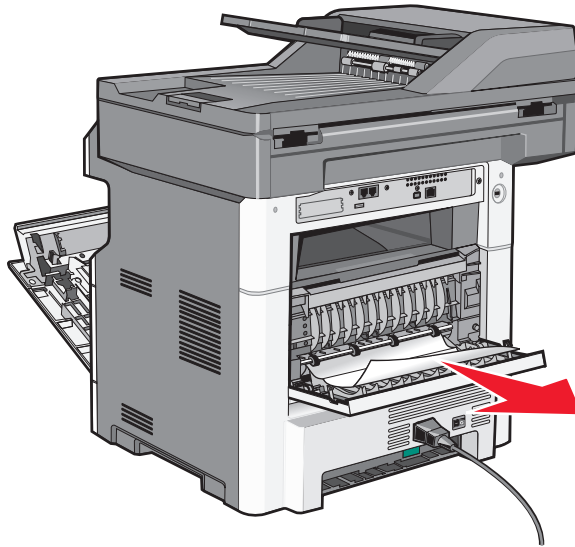

- 7 Close the rear door.
- 8 Insert the photoconductor kit and toner cartridge.
- 9 Close the front door.
- 10 Touch **Continue**.

202 paper jam

Touch **Status/Supplies** to identify the location of the jam. If the paper is exiting the printer, then pull the paper out, and then touch **Continue**.

If the paper is not exiting the printer:

- 1 Pull down the rear door.

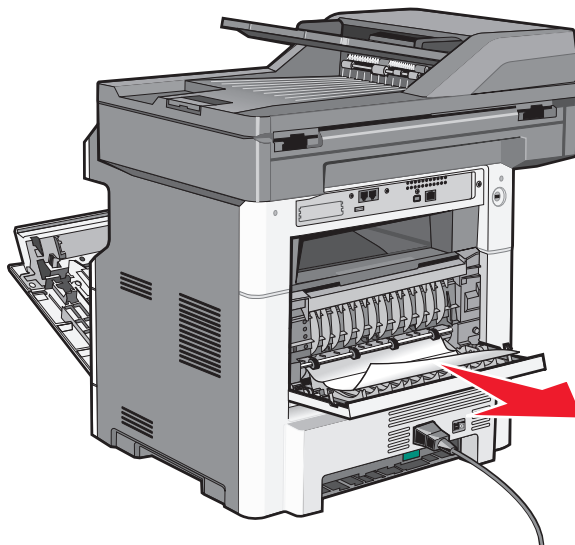

- 2 Remove the jammed paper.

- 3 Close the rear door.
- 4 Touch **Continue**.

231 paper jam

 **CAUTION—HOT SURFACE:** The inside of the printer might be hot. To reduce the risk of injury from a hot component, allow the surface to cool before touching.

- 1 Open the front door.

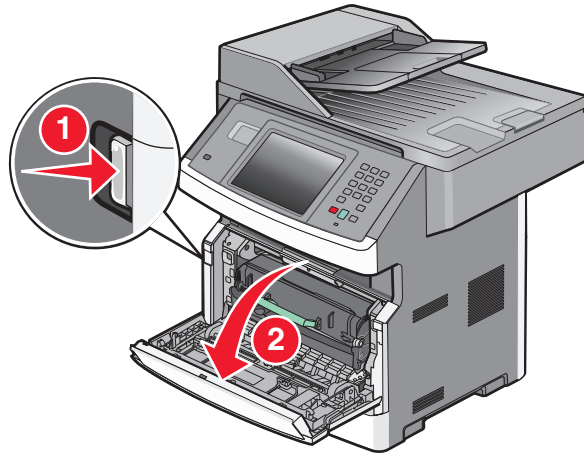

- 2 Open the rear door.
- 3 Remove the jam.

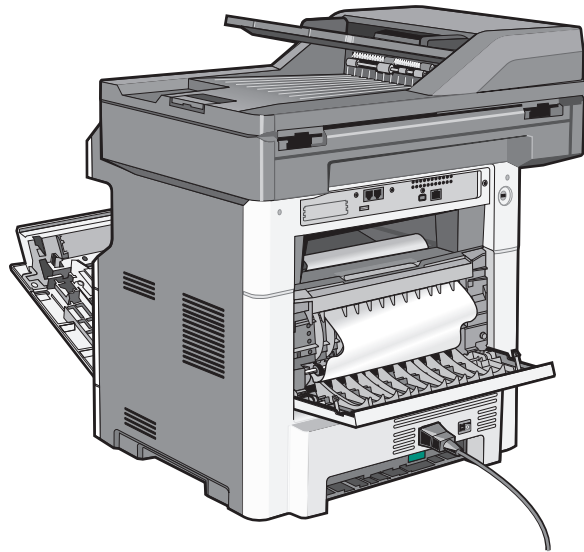

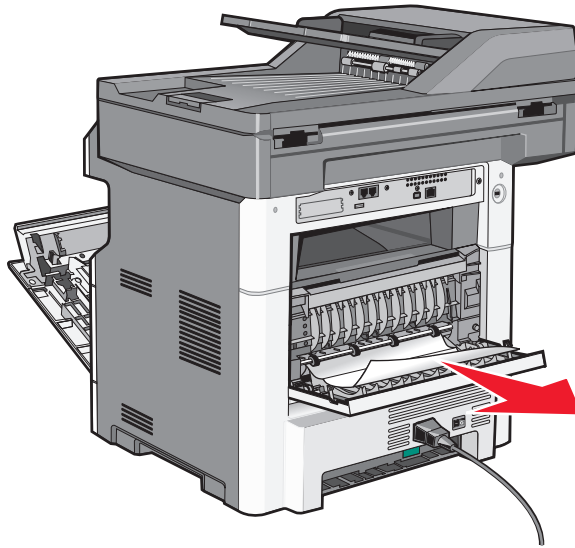

- 4 Close the rear door.
- 5 Close the front door.
- 6 Touch **Continue**.

233 paper jam

- 1 Remove the tray from the printer.

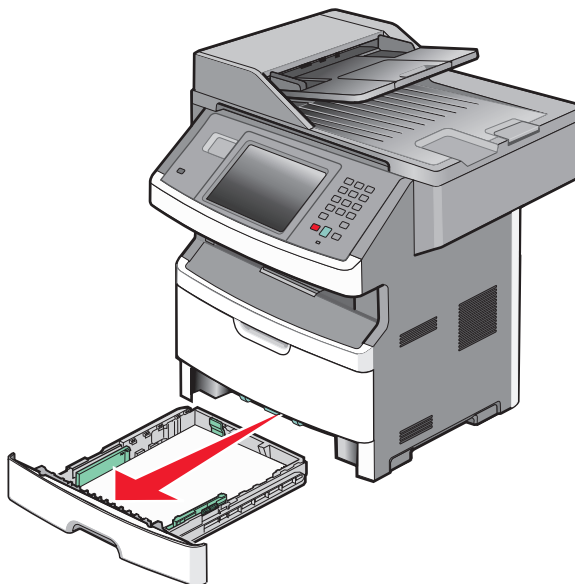

- 2 Locate the lever shown, and then pull it down to release and remove the jammed sheets.

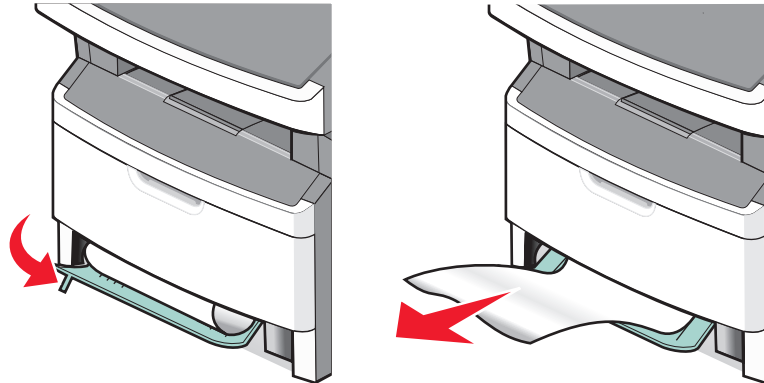

- 3 Insert the tray.
- 4 Touch **Continue**.

If this does not clear the jam, complete the steps in “231 paper jam” on page 244.

234 paper jam

A single jam or multiple jams are in the duplex area of the printer. To locate and remove the jammed sheets, complete all the steps in:

- “231 paper jam” on page 244
- “233 paper jam” on page 245

235 paper jam

- 1 Gently pull the jammed sheet out of the standard exit bin.

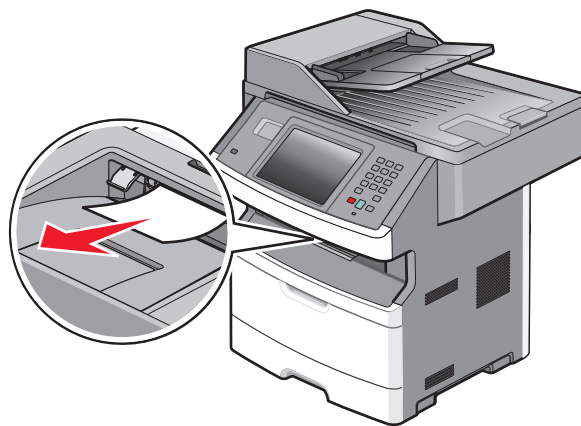

- 2 Touch **Continue**.

240–249 paper jams

- 1 Touch **Status/Supplies** to identify the location of the jam.
- 2 Pull the standard tray out.

- 3 Remove any jammed paper.



- 4 Insert the tray, and then touch **Continue**.
- 5 If the jam message persists, then pull out any optional trays.
- 6 Remove the jammed paper, and then insert the trays.
- 7 Touch **Continue**.

250 paper jam

- 1 Touch **Status/Supplies** to identify the location of the jam.
- 2 Remove the paper from the multipurpose feeder.

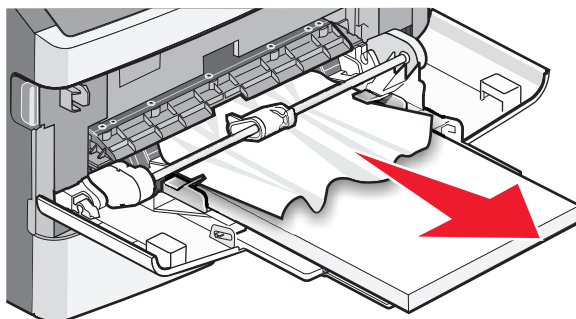

- 3 Flex the sheets of paper back and forth to loosen them, and then fan them. Do not fold or crease the paper. Straighten the edges on a level surface.
- 4 Load the paper into the multipurpose feeder.

- 5 Slide the paper guide toward the inside of the tray until it lightly rests against the edge of the paper.

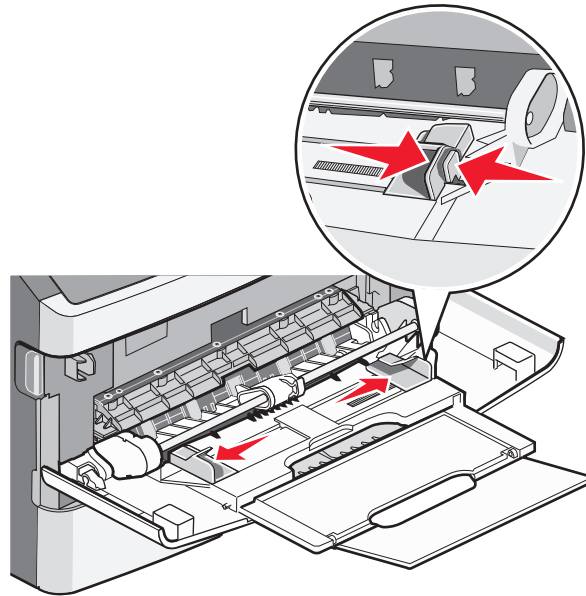

- 6 Touch **Continue**.

251 paper jam

A sheet of paper failed to feed from the multipurpose feeder. If it is visible, gently pull the jammed sheet out.

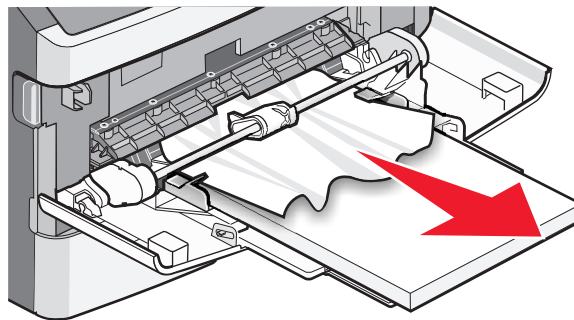

If the sheet is not visible, complete the following steps:

- 1 Open the front door, and then remove the photoconductor kit and toner cartridge.

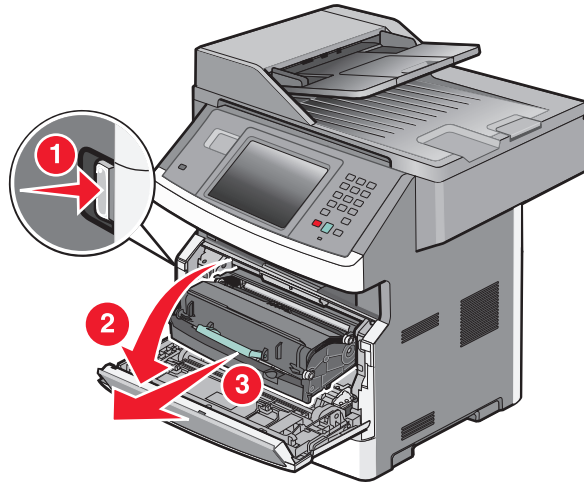

- 2 Lift the flap at the front of the printer, and then remove any jams.

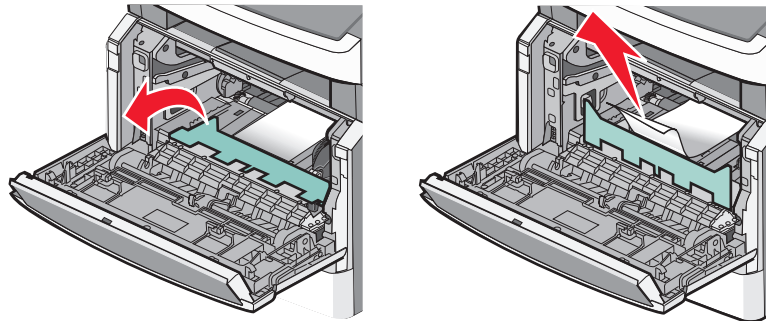

- 3 Reinsert the photoconductor kit and toner cartridge.
- 4 Close the front door.
- 5 Touch **Continue**.

290–294 paper jams

Clearing jams under the ADF cover

- 1 Remove all original documents from the ADF.
- 2 Open the ADF cover.

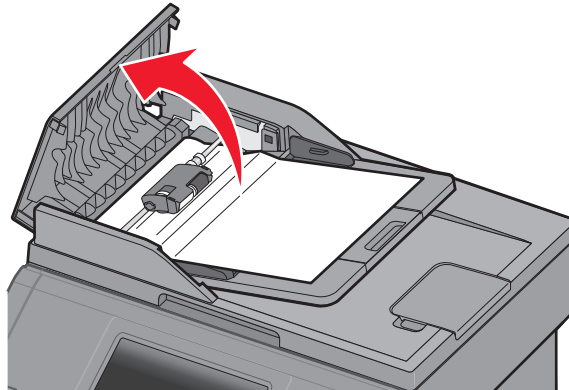

- 3 Unlock the separator roll.

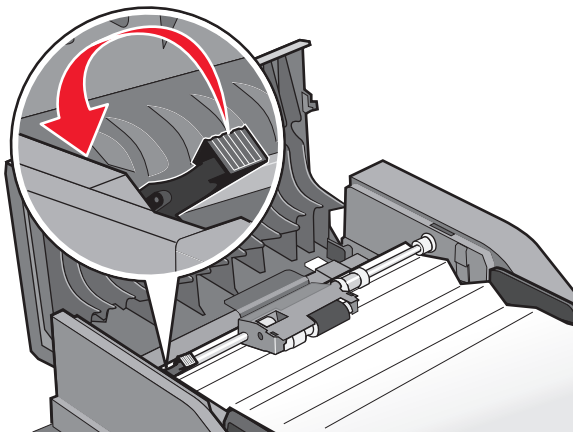

4 Remove the separator roll.

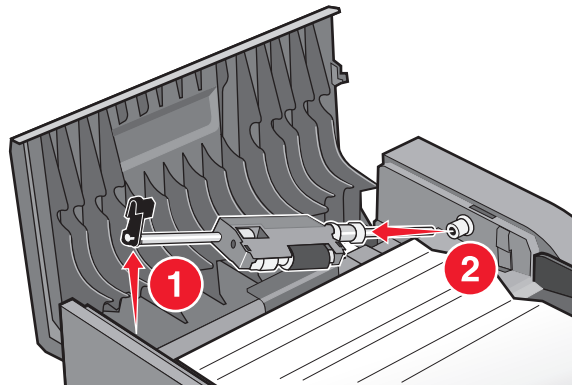

5 Remove the jammed paper.

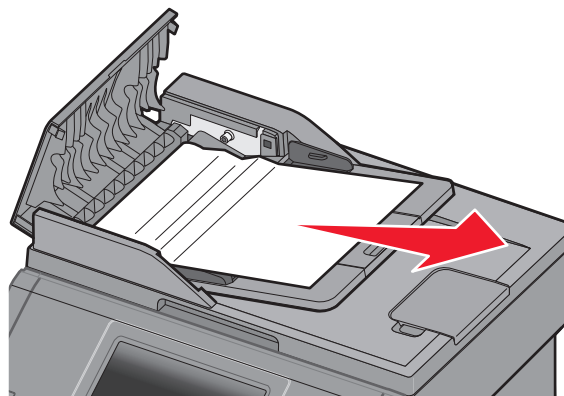

6 Reinstall the separator roll.

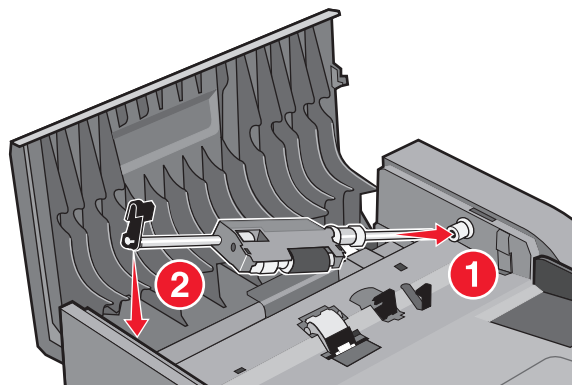

7 Lock the separator roll.

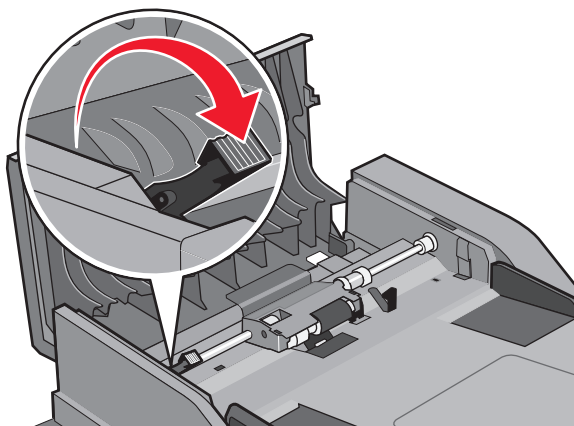

8 Close the ADF cover.

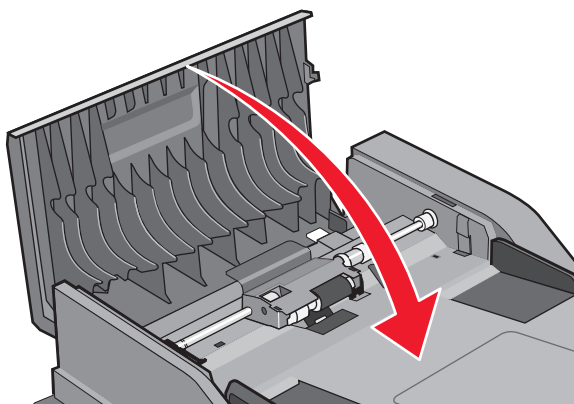

9 Touch **Continue**.

Clearing ADF jams by lifting the scanner cover

1 Open the scanner cover, and then remove any jammed pages.

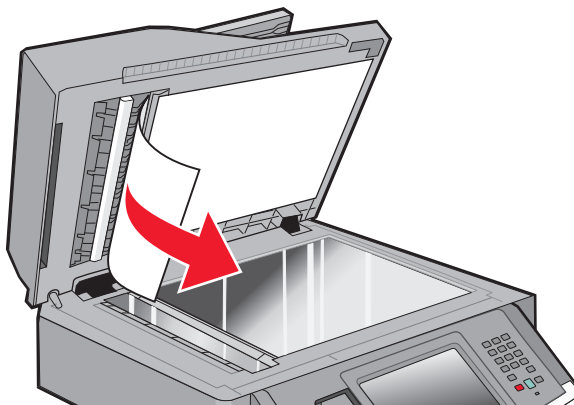

2 Touch **Continue**.

Clearing ADF duplex jams

If you are making a two-sided copy in the ADF, and your original document jams, it may be necessary to perform the following steps to clear the jam:

- 1 Remove the ADF input tray.

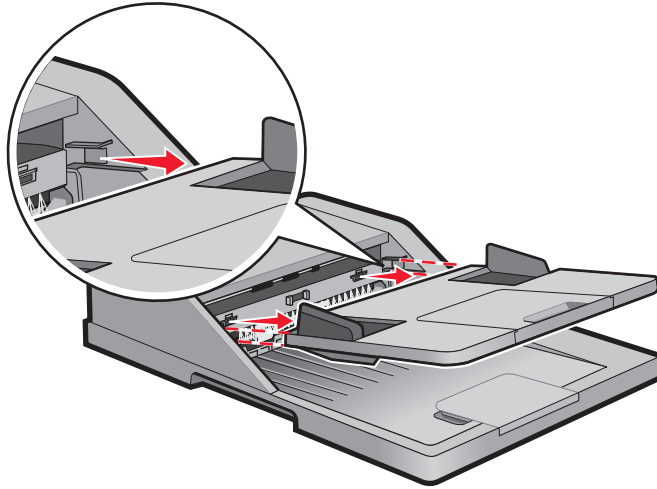

- 2 Pull out the jammed paper by pulling the sheet on the bottom.

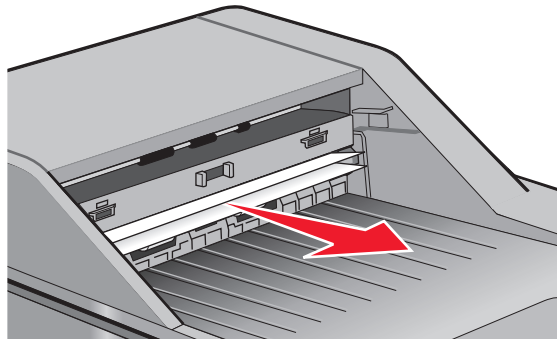

- 3 Reinstall the ADF input tray.

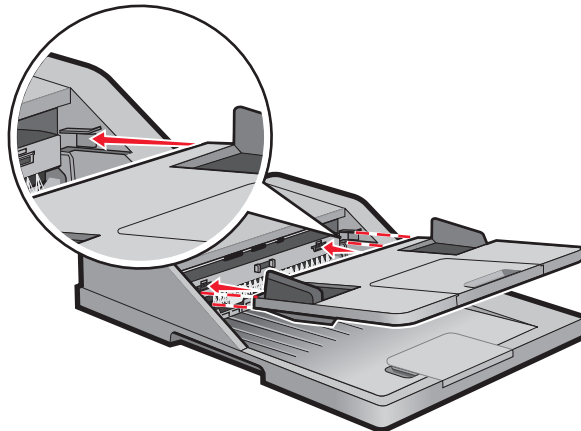

- 4 Touch **Continue**.

Troubleshooting

Solving basic printer problems

If there are basic printer problems, or the printer is unresponsive, make sure:

- The power cord is plugged into the printer and a properly grounded electrical outlet.
- The electrical outlet is not turned off by any switch or breaker.
- The printer is not plugged into any surge protectors, uninterruptible power supplies, or extension cords.
- Other electronic equipment plugged into the outlet is working.
- The printer is turned on. Check the printer power switch.
- The printer cable is securely attached to the printer and the host computer, print server, option, or other network device.
- All options are properly installed.
- The printer driver settings are correct.

Once you have checked each of these possibilities, turn the printer off, wait for about 10 seconds, and then turn the printer back on. This often fixes the problem.

Printer control panel display is blank or displays only diamonds

The printer self test failed. Turn the printer off, wait about 10 seconds, and then turn the printer on.

If **Ready** does not appear, then turn the printer off and contact Customer Support.

Indicator light blinks red

CHECK THE DISPLAY FOR ERROR MESSAGES

Clear any error messages.

MAKE SURE THE FAX FUNCTION IS SET UP PROPERLY

For more information, see “Setting up the printer to fax” on page 121.

Understanding printer messages

Answering

The printer is answering a fax call. Wait for the message to clear.

Change <src> to <x>

<src> is a tray or feeder, and <x> is a paper size or type.

You can change the current paper source for the remainder of the print job. The formatted page will print on the paper loaded in the selected tray. This may cause clipping of text or images. Try one or more of the following:

- Select the paper tray with the correct paper size or type.
- Touch **Use current [src]** to ignore the message and print from the tray selected for the print job.
- Touch **Continue** to continue the job if the correct size and type are loaded in the tray, and this size and type are specified in the printer control panel Paper menu.

Note: If you touch Continue when there is no paper in the tray, the job is not continued.

- Touch **Cancel job** to cancel the current job.

Check tray <x> connection

Try one or more of the following:

- Turn the printer off and then back on.

If the error occurs a second time:

- 1 Turn the printer off.
- 2 Unplug the power cord from the wall outlet.
- 3 Remove the tray.
- 4 Reattach the tray.
- 5 Connect the power cord to a properly grounded outlet.
- 6 Restart the printer.

If the error occurs again:

- 1 Turn the printer off.
 - 2 Unplug the power cord from the wall outlet.
 - 3 Remove the tray.
 - 4 Contact Customer Support.
- Touch **Continue** to clear the message and print without using the tray.

Close front door

Close the front door of the printer.

Close door or insert cartridge

The cartridge is missing or not installed correctly. Insert the cartridge, and then close all doors and covers.

Connect <x>bps

The fax is connected. Wait for the message to clear.

Note: <x> is the baud rate per second.

Disk corrupted

The printer attempted a hard disk recovery on a corrupted hard disk, and the hard disk cannot be repaired. The hard disk must be reformatted.

Touch **Reformat disk** to reformat the hard disk and clear the message.

Note: Reformatting the disk deletes all the files currently stored on the disk.

Disk Full - Scan Job Canceled

The scan job canceled or stopped due to insufficient printer hard disk space.

Touch **Continue** to clear the message.

Fax failed

The fax failed to be sent. Wait for the message to clear.

Fax memory full

There is not enough memory to send the fax job.

Touch **Continue** to clear the message.

Fax partition inoperative. Contact system administrator.

The fax partition appears to be corrupted. Try one or more of the following:

- Touch **Continue** to clear the message.
- Turn the printer off and then back on to reset the printer. If the message appears again, then contact your system support person.

Fax server 'To Format' not set up. Contact system administrator.

The printer is in Fax Server mode, but the Fax Server setup has not been completed.

Try one or more of the following:

- Touch **Continue** to clear the message.
- Complete the Fax Server setup. If the message appears again, contact your system support person.

Fax Station Name not set up

The Fax Station Name has not been entered. Sending and receiving faxes is disabled until fax is configured properly.

Try one or more of the following:

- Touch **Continue** to clear the message.
- Complete the Analog Fax Setup. If the message appears again, contact your system support person.

Fax Station Number not set up

The Fax Station Number has not been entered. Sending and receiving faxes is disabled until fax is configured properly.

Try one or more of the following:

- Touch **Continue** to clear the message.
- Complete the Analog Fax Setup. If the message appears again, contact your system support person.

Insert Tray <x>

Insert the specified tray into the printer.

Install Tray <x>

Try one or more of the following:

- Install the specified tray:
 - 1 Turn the printer off.
 - 2 Unplug the power cord from the wall outlet.
 - 3 Install the specified tray.
 - 4 Connect the power cord to a properly grounded outlet.
 - 5 Restart the printer.
- Cancel the current job.

Invalid PIN

Enter a valid PIN.

Load <src> with <x>

<src> is a tray or feeder, and <x> is a paper type or size.

Try one or more of the following:

- Load the specified paper in the tray.
- Touch **Continue** to clear the message and continue printing.

If the printer finds a tray that has the correct paper type and size, it feeds from that tray. If the printer cannot find a tray with the correct paper type and size, it prints from the default source.

- Cancel the current job.

Load manual feeder with <x>

<x> is a paper type or size.

Try one or more of the following:

- Load the specified paper in the multipurpose feeder.
- Touch **Continue** to clear the message and continue printing.

If the printer finds a tray that has the correct paper type and size, then it feeds from that tray. If the printer cannot find a tray with the correct paper type and size, then it prints from the default source.

- Cancel the current job.

Memory full, cannot print faxes

There is not enough memory to print the fax job.

Touch **Continue** to clear the message without printing. Held faxes will attempt to print after the printer has been restarted.

Network/Network <x>

The printer is connected to the network.

Network indicates that the printer is using the standard network port built into the printer system board. **Network <x>** indicates that an internal print server is installed inside the printer or that the printer is connected to an external print server.

No analog phone line connected to modem, fax is disabled.

The printer is not detecting an analog phone line, so the fax is disabled. Connect the printer to an analog phone line.

No answer

A fax number is dialed, but no connection is made. Wait for the message to clear.

No dial tone

The printer does not have a dial tone. Wait for the message to clear.

Paper Change: Load Tray<x> <paper type>

The printer is set to print on a paper type that is different from what is loaded in Tray 1. Load Tray 1 with the correct paper type, or change the paper type settings in the Machine Settings menu or Print Properties to match what is loaded in Tray 1.

Queued for sending

The scanning process of a fax job completed, but the job is not sent yet because another fax job is being sent or received. Wait for the message to clear.

Remove originals from the scanner ADF

Remove the paper from the ADF to clear the message and continue printing.

Remove packaging material, check <x>

Remove any remaining packaging material from the specified location.

Remove paper from standard output bin

Remove the stack of paper from the standard exit bin.

Replace <x> if restarting job.

One or more messages which interrupted a scan job are now cleared. Replace the original documents in the scanner to restart the scan job. <x> is a page of the scan job.

Try one or more of the following:

- Touch **Cancel Job** if a scan job is processing when the message appears. This cancels the job and clears the message.
- Touch **Scan from Automatic Document Feeder** if the page jam recovery is active. Scanning resumes from the ADF immediately after the last successfully scanned page.
- Touch **Scan from flatbed** if page jam recovery is active. Scanning resumes from the scanner glass immediately after the last successfully scanned page.
- Touch **Finish job without further scanning** if page jam recovery is active. The job ends at the last successfully scanned page, but the job is not canceled. Successfully scanned pages go to their destination: copy, fax, e-mail, or FTP.
- Touch **Restart job** if job recovery is active. The message clears. A new scan job containing the same parameters as the previous job starts.

Restore Held Jobs?

Try one or more of the following:

- Touch **Continue** to restore all held jobs stored on the printer hard disk.
- Touch **Do not restore** if you do not want any print jobs to be restored.

Scan Document Too Long

The scan job exceeds the maximum number of pages. Touch **Cancel Job** to clear the message.

Scanner ADF Cover Open

The ADF cover is open. The message clears when the cover is closed.

Securely clearing disk space

The printer hard disk wiping process needs to recover. The message clears when all blocks are cleared.

Serial <x>

The printer is using a serial cable connection. The serial port is the active communication link.

Set clock

The clock is not set. This message appears if no other fax status message appears. It remains until the clock is set.

SMTP server not set up. Contact system administrator.

An error occurred on the SMTP server, or the SMTP server is not configured properly. Touch **Continue** to clear the message. If the message appears again, contact your system support person.

Some held jobs were not restored

Touch **Continue** to delete the specified job.

Note: Some held jobs are not restored. They stay on the hard disk and are inaccessible.

System busy, preparing resources for job.

Not all resources needed for the job are available. Wait for the message to clear.

System busy, preparing resources for job. Deleting held job(s).

Not all resources needed for the job are available. Some held jobs are deleted to free system memory. Wait for the message to clear.

Unsupported disk

An unsupported printer hard disk has been installed. Remove the unsupported device, and then install a supported one.

Unsupported USB device, please remove

Remove the unrecognized USB device.

Unsupported USB hub, please remove

Remove the unrecognized USB hub.

USB/USB <x>

The printer is using a USB cable connection. The USB port is the active communication link.

30 Invalid refill, change toner cartridge

The printer has detected an invalid, refilled toner cartridge. Remove the toner cartridge, and then install a new one.

31 Replace defective cartridge

Remove the defective toner cartridge, and then install a new one.

32 Cartridge part number unsupported by device

Remove the toner cartridge, and then install a supported one.

34 Short paper

Try one or more of the following:

- Load the appropriate paper or other specialty media in the proper tray.
- Touch **Continue** to clear the message and print the job using a different paper tray.
- Check tray length and width guides and make sure the paper is properly loaded in the tray.
- Check the Print Properties or Print dialog settings to make sure the print job is requesting the correct paper size and type.
- Check that the paper size is correctly set. For example, if the MP Feeder Size is set to Universal, make sure the paper is large enough for the data being printed.
- Cancel the current print job.

35 Insufficient memory to support Resource Save feature

Try one or more of the following:

- Touch **Continue** to disable Resource Save and continue printing.
- To enable Resource Save after receiving this message, make sure the link buffers are set to Auto, and then exit the menus to activate the link buffer changes. When **Ready** appears, enable Resource Save.
- Install additional memory.

37 Insufficient memory to collate job

Try one or more of the following:

- Touch **Continue** to print the portion of the job already stored and begin collating the rest of the print job.
- Cancel the current print job.

37 Insufficient memory, some Held Jobs were deleted

The printer deleted some held jobs in order to process current jobs.

Touch **Continue** to clear the message.

37 Insufficient memory, some held jobs will not be restored

The printer was unable to restore some or all of the confidential or held jobs on the printer hard disk.

Touch **Continue** to clear the message.

38 Memory full

Try one or more of the following:

- Touch **Continue** to clear the message.
- Cancel the current print job.
- Install additional printer memory.

39 Complex page, some data may not have printed

Try one or more of the following:

- Touch **Continue** to clear the message and continue printing.
- Cancel the current print job.
- Install additional printer memory.

50 PPDS font error

Try one or more of the following:

- Touch **Continue** to clear the message and continue printing.
- The printer cannot find a requested font. From the PPDS menu, select **Best Fit**, and then select **On**. The printer will find a similar font and reformat the affected text.
- Cancel the current print job.

51 Defective flash detected

Try one or more of the following:

- Touch **Continue** to clear the message and continue printing.
- Cancel the current print job.

52 Not enough free space in flash memory for resources

Try one or more of the following:

- Touch **Continue** to clear the message and continue printing.
Downloaded fonts and macros not previously stored in flash memory are deleted.
- Delete fonts, macros, and other data stored in flash memory.
- Upgrade to a larger capacity flash memory card.

53 Unformatted flash detected

Try one or more of the following:

- Touch **Continue** to stop the defragment operation and continue printing.
- Format the flash memory. If the error message remains, the flash memory may be defective and require replacing.

54 Network <x> software error

<x> is the number of the network connection.

Try one or more of the following:

- Touch **Continue** to continue printing.
- Turn the printer off and then back on to reset the printer.
- Upgrade (flash) the network firmware in the printer or print server.

54 Serial option <x> error

<x> is the number of the serial option.

Try one or more of the following:

- Check that the serial cable is connected correctly and is the proper one for the serial port.
- Check that the serial interface parameters (protocol, baud, parity, and data bits) are set correctly on the printer and host computer.
- Touch **Continue** to continue printing.
- Turn the printer power off and then back on to reset the printer.

54 Standard network software error

Try one or more of the following:

- Touch **Continue** to continue printing.
- Turn the printer off and then back on to reset the printer.
- Upgrade (flash) the network firmware in the printer or print server.

55 Unsupported option in slot <x>

<x> is a slot on the printer system board.

Try one or more of the following:

- 1 Turn the printer power off.
- 2 Unplug the power cord from the wall outlet.
- 3 Remove the unsupported option card from the printer system board.
- 4 Connect the power cord to a properly grounded outlet.
- 5 Turn the printer power back on.

56 Parallel port <x> disabled

<x> is the number of the parallel port.

Try one or more of the following:

- Touch **Continue** to clear the message.
The printer discards any data received through the parallel port.
- Make sure the Parallel Buffer menu item is not set to Disabled.

56 Serial port <x> disabled

<x> is the number of the serial port.

Try one or more of the following:

- Touch **Continue** to clear the message.
The printer discards any data received through the serial port.
- Make sure the Serial Buffer menu item is not set to Disabled.

56 Standard parallel port disabled

Try one or more of the following:

- Touch **Continue** to clear the message.
The printer discards any data received through the parallel port.
- Make sure the Parallel Buffer menu item is not set to Disabled.

56 Standard USB port disabled

Try one or more of the following:

- Touch **Continue** to clear the message.
The printer discards any data received through the USB port.
- Make sure the USB Buffer menu item is not set to Disabled.

56 USB port <x> disabled

<x> is the number of the USB port.

Try one or more of the following:

- Touch **Continue** to clear the message.
The printer discards any data received through the USB port.
- Make sure the USB Buffer menu item is not set to Disabled.

57 Configuration change, held jobs were not restored

Since the time the jobs were stored on the printer hard disk something has changed in the printer to invalidate the held jobs. Possible changes include:

- The printer firmware has been updated.
- Paper input, output, or duplex options needed for the print job were removed.
- The print job was created using data from a device in the USB port and the device is no longer in the port.
- The printer hard disk contains jobs that were stored while installed in a different printer model.

Touch **Continue** to clear the message.

58 Too many trays attached

- 1 Turn the printer off.
- 2 Unplug the power cord from the wall outlet.
- 3 Remove the additional trays.
- 4 Connect the power cord to a properly grounded outlet.
- 5 Turn the printer back on.

58 Too many flash options installed

- 1 Turn the printer off.
- 2 Unplug the power cord from the wall outlet.
- 3 Remove the excess flash memory.
- 4 Connect the power cord to a properly grounded outlet.
- 5 Turn the printer back on.

59 Incompatible tray <x>

Try one or more of the following:

- Remove the specified tray.
- Touch **Continue** to clear the message and continue printing without using the specified tray.

61 Remove defective disk

Try one or more of the following:

- Touch **Continue** to clear the message and continue printing.
- Install a different printer hard disk before performing any operations that require a printer hard disk.

62 Disk full

Try one or more of the following:

- Touch **Continue** to clear the message and continue processing.
- Delete fonts, macros, and other data stored on the printer hard disk.
- Install a larger printer hard disk.

63 Unformatted disk

Try one or more of the following:

- Touch **Continue** to clear the message and continue printing.
- Format the printer hard disk.

If the error message remains, the hard disk may be defective and require replacing.

80 Routine maintenance needed

The printer needs to have routine maintenance done. Order a maintenance kit, which contains all the items necessary to replace the pick rollers, the charge roll, the transfer roller, and the fuser.

84 Replace PC Kit

The photoconductor kit is exhausted. Install a new photoconductor kit.

84 PC Kit life warning

The photoconductor kit is near exhaustion.

Try one or more of the following:

- Replace the photoconductor kit.
- Touch **Continue** to clear the message and continue printing.

88 Cartridge low

The toner is low. Replace the toner cartridge, and then touch **Continue** to clear the message and continue printing.

88.yy Cartridge nearly low

The toner is low. Replace the toner cartridge, and then touch **Continue** to clear the message and continue printing.

88.yy Replace cartridge

The toner cartridge is empty.

- 1 Replace the toner cartridge.
- 2 Touch **Continue** to clear the message.

200–282.yy paper jam

- 1 Clear the paper path.
- 2 Touch **Continue** to continue printing.

290-295.yy scanner jam

Clear all original documents from the scanner.

293 Replace all originals if restarting job.

The scanner was instructed to scan using the ADF but there is no paper in the ADF. Load paper in the ADF.

Try one or more of the following:

- Touch **Continue** if no scan job is active when the attendance message appears. This clears the message.
- Touch **Cancel Job** if a scan job is processing when the attendance message appears. This cancels the job and clears the message.
- Touch **Scan from Automatic Document Feeder** if the page jam recovery is active. Scanning resumes from the ADF immediately after the last successfully scanned page.
- Touch **Scan from flatbed** if page jam recovery is active. Scanning resumes from the flatbed immediately after the last successfully scanned page.
- Touch **Finish job** without further scanning if page jam recovery is active. The job ends at the last successfully scanned page, but the job is not canceled. Successfully scanned pages go to their destination: copy, fax, e-mail, or FTP.
- Touch **Restart job** if job recovery is active and you are able to restart the job. The message clears. A new scan job containing the same parameters as the previous job starts.

293.02 Flatbed Cover Open

Close the scanner cover.

294 ADF Jam

This jam location may also be identified as **294.04 Duplex Sensor Off Jam**, **294.05 Scan Sensor Off Jam**, or **294.06 ADF Backfeed Jam**. To clear this jam:

- 1 Remove all pages from the ADF.
Note: The message clears when the pages are removed from the ADF.
- 2 Flex and fan the pages.
- 3 Place the pages in the ADF.
- 4 Adjust the ADF guides.
- 5 From the printer control panel, press .

840.01 Scanner Disabled

This message indicates that the scanner was disabled by the system support person, or the scanner detected a hardware error and disabled itself.

841-846 Scanner Service Error

- 1 Turn the printer off.
- 2 Unplug the power cord from the wall outlet.
- 3 Check all cable connections.
- 4 Connect the power cord to a properly grounded outlet.
- 5 Turn the printer back on.

If the service message appears again, then contact Customer Support, and report the message.

900–999 Service <message>

- 1 Turn the printer off.
- 2 Unplug the power cord from the wall outlet.
- 3 Check all cable connections.
- 4 Connect the power cord to a properly grounded outlet.
- 5 Turn the printer back on.

If the service message appears again, contact Customer Support, and report the message.

1565 Emulation error, load emulation option

The printer automatically clears the message in 30 seconds and then disables the download emulator on the firmware card.

To fix this, download the correct download emulator version from the Lexmark Web site at www.lexmark.com.

Solving printing problems

Multiple-language PDFs do not print

The documents contain unavailable fonts.

- 1 Open the document you want to print in Adobe Acrobat.
- 2 Click the printer icon.
The Print dialog appears.
- 3 Click **Advanced**.

4 Select **Print as image**.

5 Click **OK** twice.

Error message about reading USB drive appears

Make sure the USB drive is supported. For information regarding tested and approved USB flash memory devices, visit the Lexmark Web site at www.lexmark.com.

Jobs do not print

These are possible solutions. Try one or more of the following:

MAKE SURE THE PRINTER IS READY TO PRINT

Make sure **Ready** or **Power Saver** appears on the display before sending a job to print.

CHECK TO SEE IF THE STANDARD EXIT BIN IS FULL

Remove the stack of paper from the standard exit bin.

CHECK TO SEE IF THE PAPER TRAY IS EMPTY

Load paper in the tray.

MAKE SURE THE CORRECT PRINTER SOFTWARE IS INSTALLED

- Verify that you are using the correct printer software.
- If you are using a USB port, make sure you are running a supported operating system and using compatible printer software.

MAKE SURE THE INTERNAL PRINT SERVER IS INSTALLED PROPERLY AND WORKING

- Make sure the internal print server is properly installed and that the printer is connected to the network. For more information about installing a network printer, click **View User's Guide and Documentation** on the *Software and Documentation* CD.
- Print a network setup page and check that the status shows **Connected**. If the status is **Not Connected**, check the network cables, and then try printing the network setup page again. Contact your system support person to make sure the network is functioning correctly.

Copies of the printer software are also available on the Lexmark Web site at www.lexmark.com.

MAKE SURE YOU ARE USING A RECOMMENDED PRINTER CABLE

For more information, visit the Lexmark Web site at www.lexmark.com.

MAKE SURE PRINTER CABLES ARE SECURELY CONNECTED

Check the cable connections to the printer and print server to make sure they are secure.

For more information, see the setup documentation that came with the printer.

Confidential and other held jobs do not print

These are possible solutions. Try one or more of the following:

PARTIAL JOB, NO JOB, OR BLANK PAGES PRINT

The print job may contain a formatting error or invalid data.

- Delete the print job, and then print it again.
- For PDF documents, recreate the PDF and then print it again.

MAKE SURE THE PRINTER HAS SUFFICIENT MEMORY

Free up additional printer memory by scrolling through the list of held jobs and deleting some of them.



Job takes longer than expected to print

These are possible solutions. Try one or more of the following:

REDUCE THE COMPLEXITY OF THE PRINT JOB

Reduce the number and size of fonts, the number and complexity of images, and the number of pages in the job.

CHANGE THE PAGE PROTECT SETTING TO OFF

- 1 On the home screen, touch .
- 2 Touch **Settings**.
- 3 Touch **General Settings**.
- 4 Touch the down arrow until **Print Recovery** appears.
- 5 Touch **Print Recovery**.
- 6 Touch the arrows next to **Page Protect** until **Off** appears.
- 7 Touch **Submit**.
- 8 Touch  to return to the home screen.

CHANGE ENVIRONMENTAL SETTINGS

When using Eco-Mode or Quiet Mode settings, you may notice a short delay before the first page is printed. If you want to change the settings and need more information, then see “Using Eco-Mode” on page 69 or “Reducing printer noise” on page 73.

Job prints from the wrong tray or on the wrong paper

CHECK THE PAPER TYPE SETTING

Make sure the paper type setting matches the paper loaded in the tray:

- 1 From the printer control panel, check the Paper Type setting from the Paper menu.
- 2 Before sending the job to print, specify the correct type setting:
 - For Windows users, specify the type from Print Properties.
 - For Macintosh users, specify the type from the Print dialog.

Incorrect characters print

MAKE SURE THE PRINTER IS NOT IN HEX TRACE MODE

If **Ready Hex** appears on the display, then you must exit Hex Trace mode before you can print your job. Turn the printer off and back on to exit Hex Trace mode.

Tray linking does not work

These are possible solutions. Try one or more of the following:

LOAD THE SAME SIZE AND TYPE OF PAPER

- Load the same size and type of paper in each tray to be linked.
- Move the paper guides to the correct positions for the paper size loaded in each tray.

USE THE SAME PAPER SIZE AND PAPER TYPE SETTINGS

- Print a menu settings page and compare the settings for each tray.
- If necessary, adjust the settings from the Paper Size/Type menu.

Note: The multipurpose feeder does not automatically sense the paper size. You must set the size from the Paper Size/Type menu.

Large jobs do not collate

These are possible solutions. Try one or more of the following:

MAKE SURE COLLATE IS SET TO ON

From the Finishing menu or Print Properties, set Collate to On.

Note: Setting Collate to Off in the software overrides the setting in the Finishing menu.

REDUCE THE COMPLEXITY OF THE PRINT JOB



Reduce the complexity of the print job by eliminating the number and size of fonts, the number and complexity of images, and the number of pages in the job.

MAKE SURE THE PRINTER HAS ENOUGH MEMORY

Add printer memory or an optional hard disk.

Unexpected page breaks occur

INCREASE THE PRINT TIMEOUT VALUE

- 1 Make sure the printer is on and **Ready** appears.
- 2 On the home screen, touch .
- 3 Touch **Settings**.
- 4 Touch **General Settings**.
- 5 Touch the down arrow until **Timeouts** appears.
- 6 Touch **Timeouts**.
- 7 Touch the left or right arrow next to **Print Timeout** until the desired value appears.
- 8 Touch **Submit**.
- 9 Touch .

Solving copy problems

Copier does not respond

These are possible solutions. Try one or more of the following:

CHECK THE DISPLAY FOR ERROR MESSAGES

Clear any error messages.

CHECK THE POWER

Make sure the printer is plugged in, the power is on, and **Ready** appears.

Scanner unit does not close

Make sure there are no obstructions:

- 1 Lift the scanner unit.
- 2 Remove any obstruction keeping the scanner unit open.
- 3 Lower the scanner unit.

Poor copy quality

These are some examples of poor copy quality:

- Blank pages
- Checkerboard pattern
- Distorted graphics or pictures
- Missing characters
- Faded print
- Dark print
- Skewed lines
- Smudges
- Streaks
- Unexpected characters
- White lines in print

These are possible solutions. Try one or more of the following:

CHECK THE DISPLAY FOR ERROR MESSAGES

Clear any error messages.

THE TONER MAY BE LOW

When **88 Cartridge low** appears or when the print becomes faded, replace the toner cartridge.

THE SCANNER GLASS MAY BE DIRTY

Clean the scanner glass with a clean, lint-free cloth dampened with water. If your printer has an ADF, be sure to clean the ADF scanner glass as well. For more information, see: "Cleaning the scanner glass" on page 229.

THE COPY IS TOO LIGHT OR TOO DARK

Adjust the copy darkness setting.

CHECK THE QUALITY OF THE ORIGINAL DOCUMENT

Make sure the quality of the original document is satisfactory.

CHECK THE DOCUMENT PLACEMENT

- Make sure the document or photo is loaded facedown on the scanner glass in the upper left corner.
- If you previously loaded your original document into the ADF, try loading it on the scanner glass.

UNWANTED TONER IS IN THE BACKGROUND

- Adjust the darkness to a lighter setting.
- Change the **Background Removal** setting in the **Copy Settings** menu.

PATTERNS (MOIRÉ) APPEAR IN THE OUTPUT

- From the printer control panel, press the **Content** button until the light comes on next to Text/Photo.
- Rotate the original document on the scanner glass.
- From the printer control panel, press the **Scale** button and adjust the setting.

TEXT IS LIGHT OR DISAPPEARING

From the printer control panel, press the **Content** button until the light comes on next to Text or Text/Photo.

THE OUTPUT APPEARS WASHED OUT OR OVEREXPOSED

- From the printer control panel, press the **Content** button until the light comes on next to Text/Photo or Photo.
- From the printer control panel, press the **Darkness** button and change to a darker setting.

THE PRINT IS SKEWED

Notes:

- If you are loading your original document in the ADF, adjust the ADF paper guides so they touch the edges of the pages to be scanned.
- Check the paper trays to make sure the guides touch the edges of the loaded paper.

Partial document or photo copies

These are possible solutions. Try one or more of the following:

CHECK THE DOCUMENT PLACEMENT

Make sure the document or photo is loaded facedown on the scanner glass in the upper left corner.

CHECK THE PAPER SIZE SETTING

Make sure the paper size setting matches the paper loaded in the tray:

- 1** From the printer control panel Paper menu, check the Paper Size setting.
- 2** Before sending the job to print, specify the correct size setting:
 - For Windows users, specify the size from Print Properties.
 - For Macintosh users, specify the size from the Page Setup or Print dialog.

Solving scanner problems

Checking an unresponsive scanner

If your scanner is not responding, then make sure:

- The printer is turned on.
- The printer cable is securely attached to the printer and the host computer, print server, option, or other network device.
- The power cord is plugged into the printer and a properly grounded electrical outlet.
- The electrical outlet is not turned off by any switch or breaker.
- The printer is not plugged into any surge protectors, uninterruptible power supplies, or extension cords.
- Other electrical equipment plugged into the outlet is working.

Once you have checked each of these possibilities, turn the printer off and then back on. This often fixes the problem with the scanner.

Scan was not successful

These are possible solutions. Try one or more of the following:

CHECK THE CABLE CONNECTIONS

Make sure the network or USB cable is securely connected to the computer and the printer.

AN ERROR MAY HAVE OCCURRED IN THE PROGRAM

Turn off and then restart the computer.

Scanning takes too long or freezes the computer

These are possible solutions. Try one or more of the following:

OTHER SOFTWARE PROGRAMS MAY BE INTERFERING WITH SCANNING

Close all programs not being used.

THE SCAN RESOLUTION MAY BE SET TOO HIGH

Select a lower scan resolution.

Poor scanned image quality

These are possible solutions. Try one or more of the following:

CHECK THE DISPLAY FOR ERROR MESSAGES

Clear any error messages.

THE SCANNER GLASS MAY BE DIRTY

Clean the scanner glass with a clean, lint-free cloth dampened with water. For more information, see “Cleaning the scanner glass” on page 229.

ADJUST THE SCAN RESOLUTION

Increase the resolution of the scan for a higher quality output.

CHECK THE QUALITY OF THE ORIGINAL DOCUMENT

Make sure the quality of the original document is satisfactory.

CHECK THE DOCUMENT PLACEMENT

Make sure the document or photo is loaded facedown on the scanner glass in the upper left corner.

Partial document or photo scans

These are possible solutions. Try one or more of the following:

CHECK THE DOCUMENT PLACEMENT

Make sure the document or photo is loaded facedown on the scanner glass in the upper left corner.

CHECK THE PAPER SIZE SETTING

Make sure the paper size setting matches the paper loaded in the tray:

- 1** From the printer control panel Paper menu, check the Paper Size setting.
- 2** Before sending the job to print, specify the correct size setting:
 - For Windows users, specify the size from Print Properties.
 - For Macintosh users, specify the size from the Page Setup or Print dialog.

Cannot scan from a computer

These are possible solutions. Try one or more of the following:

CHECK THE DISPLAY FOR ERROR MESSAGES

Clear any error messages.

CHECK THE POWER

Make sure the printer is plugged in, the power is on, and **Ready** appears.

CHECK THE CABLE CONNECTIONS

Make sure the network or USB cable is securely connected to the computer and the printer.

Solving fax problems

Caller ID is not shown

Contact your telecommunications company to verify that your telephone line is subscribed to the caller ID service.

If your region supports multiple caller ID patterns, you may have to change the default setting. There are two settings available: FSK (pattern 1) and DTMF (pattern 2). The availability of these settings by way of the Fax menu depends on whether your country or region supports multiple caller ID patterns. Contact your telecommunications company to determine which pattern or switch setting to use.

Cannot send or receive a fax

These are possible solutions. Try one or more of the following:

ENABLE THE FAX FUNCTION

For more information, see “Setting up the printer to fax” on page 121.

CHECK THE DISPLAY FOR ERROR MESSAGES

Clear any error messages.

CHECK THE POWER

Make sure the printer is plugged in, the power is on, and **Ready** appears.

CHECK THE PRINTER CONNECTIONS

Make sure the cable connections for the following hardware are secure, if applicable:

- Telephone
- Handset
- Answering machine

CHECK THE TELEPHONE WALL JACK

- 1 Plug a telephone into the wall jack.
- 2 Listen for a dial tone.
- 3 If you do not hear a dial tone, then plug a different telephone into the wall jack.
- 4 If you still do not hear a dial tone, then plug a telephone into a different wall jack.
- 5 If you hear a dial tone, then connect the printer to that wall jack.

REVIEW THIS DIGITAL PHONE SERVICE CHECKLIST

The fax modem is an analog device. Certain devices can be connected to the printer so that digital telephone services can be used.

- If you are using an ISDN telephone service, then connect the printer to an analog telephone port (an R-interface port) on an ISDN terminal adapter. For more information and to request an R-interface port, contact your ISDN provider.
- If you are using DSL, then connect to a DSL filter or router that will support analog use. For more information, contact your DSL provider.
- If you are using a PBX telephone service, then make sure you are connecting to an analog connection on the PBX. If none exists, consider installing an analog telephone line for the fax machine.

CHECK FOR A DIAL TONE

- Place a test call to the telephone number to which you want to send a fax to make sure that it is working correctly.
- If the telephone line is being used by another device, then wait until the other device is finished before sending a fax.
- If you are using the On Hook Dial feature, then turn up the volume to verify a dial tone.

TEMPORARILY DISCONNECT OTHER EQUIPMENT

To ensure the printer is working correctly, connect it directly to the telephone line. Disconnect any answering machines, computers with modems, or telephone line splitters.

CHECK FOR JAMS

Clear any jams, and then make sure that **Ready** appears.

TEMPORARILY DISABLE CALL WAITING

Call Waiting can disrupt fax transmissions. Disable this feature before sending or receiving a fax. Call your telephone company to obtain the keypad sequence for temporarily disabling Call Waiting.

VOICE MAIL SERVICE MAY BE INTERFERING WITH THE FAX TRANSMISSION

Voice Mail offered through your local telephone company may disrupt fax transmissions. To enable both Voice Mail and the printer to answer calls, you may want to consider adding a second telephone line for the printer.

THE PRINTER MEMORY MAY BE FULL

- 1 Dial the fax number.
- 2 Scan the original document one page at a time.

Can send but not receive faxes

These are possible solutions. Try one or more of the following:

CHECK TO SEE IF THE PAPER TRAY IS EMPTY

Load paper in the tray.

CHECK THE RING COUNT DELAY SETTINGS

The ring count delay sets the number of times the phone line rings before the printer answers. If you have extension phones on the same line as the printer, or subscribe to the telephone company's Distinctive Ring service, then keep the Ring Delay setting at 4.

1 Type the printer IP address into the address field of your Web browser.

Note: If you do not know the IP address of the printer, then print a network setup page and locate the IP address in the TCP/IP section.

2 Click **Settings**.

3 Click **Fax Settings**.

4 Click **Analog Fax Setup**.

5 In the Rings to Answer box, enter the number of times you want the phone to ring before answering.

6 Click **Submit**.

THE TONER MAY BE LOW

88 Cartridge low appears when the toner is low.

Can receive but not send faxes

These are possible solutions. Try one or more of the following:

THE PRINTER IS NOT IN FAX MODE

On the home screen, touch **Fax** to put the printer in Fax mode.

THE DOCUMENT IS NOT LOADED PROPERLY

Load the original document faceup, short edge first into the ADF or facedown on the scanner glass in the upper left corner.

Note: Do not load postcards, photos, small items, transparencies, photo paper, or thin media (such as magazine clippings) into the ADF. Place these items on the scanner glass.

MAKE SURE THE SHORTCUT NUMBER IS SET UP PROPERLY

- Check to make sure the shortcut number has been programmed for the number that you want to dial.
- As an alternative, dial the telephone number manually.

Received fax has poor print quality

These are possible solutions. Try one or more of the following:

RE-SEND THE DOCUMENT

Ask the person who sent you the fax to:

- Check that the quality of the original document is satisfactory.
- Resend the fax. There may have been a problem with the quality of the telephone line connection.
- Increase the fax scan resolution, if possible.

THE TONER MAY BE LOW

When **88 Cartridge low** appears or when you experience faded print, replace the cartridge.

MAKE SURE THE FAX TRANSMISSION SPEED IS NOT SET TOO HIGH

Decrease the incoming fax transmission speed:

- 1 Type the printer IP address into the address field of your Web browser.

Note: If you do not know the IP address of the printer, then print a network setup page and locate the IP address in the TCP/IP section.

- 2 Click **Settings**.

- 3 Click **Fax Settings**.

- 4 Click **Analog Fax Setup**.

- 5 In the Max Speed box, click on one of the following:

2400

4800

9600

14400

33600

- 6 Click **Submit**.

Solving option problems

Option does not operate correctly or quits after it is installed

These are possible solutions. Try one or more of the following:

RESET THE PRINTER

Turn the printer off, wait about 10 seconds, and then turn the printer on.

CHECK TO SEE IF THE OPTION IS CONNECTED TO THE PRINTER

- 1 Turn the printer off.
- 2 Unplug the printer.
- 3 Check the connection between the option and the printer.

MAKE SURE THE OPTION IS INSTALLED CORRECTLY

Print a menu settings page and check to see if the option is listed in the Installed Options list. If the option is not listed, then reinstall it. For more information, see the hardware setup documentation that came with the option, or go to www.lexmark.com/publications to view the option instruction sheet.

MAKE SURE THE OPTION IS SELECTED

From the computer you are printing from, select the option. For more information, see “Updating available options in the printer driver” on page 53.

Drawers

These are possible solutions. Try one or more of the following:

MAKE SURE THE PAPER IS LOADED CORRECTLY

- 1 Pull the tray completely out.
- 2 Check for paper jams or misfeeds.
- 3 Make sure the guides are aligned against the edges of the paper.
- 4 Insert the tray.

RESET THE PRINTER

Turn the printer off, wait about 10 seconds, and then turn the printer on.

Flash memory card

Make sure the flash memory card is securely connected to the printer system board.

Hard disk with adapter

Make sure the hard disk is securely connected to the printer system board.

Internal Solutions Port

If the Lexmark Internal Solutions Port (ISP) does not operate correctly, then these are possible solutions. Try one or more of the following:

CHECK THE ISP CONNECTIONS

- Make sure the ISP is securely attached to the printer system board.
- Make sure the cable is securely connected to the correct connector.

CHECK THE CABLE

Make sure you are using the correct cable and that it is securely connected.

MAKE SURE THE NETWORK SOFTWARE IS CONFIGURED CORRECTLY

For information about installing software for network printing, see the *Networking Guide* on the *Software and Documentation CD*

Memory card

Make sure the memory card is securely connected to the printer system board.

Solving paper feed problems

Paper frequently jams

These are possible solutions. Try one or more of the following:

CHECK THE PAPER

Use recommended paper and specialty media. For more information, see the chapter about paper and specialty media guidelines.

MAKE SURE THERE IS NOT TOO MUCH PAPER IN THE PAPER TRAY

Make sure the stack of paper you load does not exceed the maximum stack height indicated in the tray or on the multipurpose feeder.

CHECK THE PAPER GUIDES

Move the guides in the tray to the correct positions for the paper size loaded.

THE PAPER MAY HAVE ABSORBED MOISTURE DUE TO HIGH HUMIDITY

- Load paper from a fresh package.
- Store paper in its original wrapper until you use it.

Paper trays

These are possible solutions. Try one or more of the following:

MAKE SURE THE PAPER IS LOADED CORRECTLY

- 1 Open the paper tray.
- 2 Check for paper jams or misfeeds.
- 3 Make sure paper guides are aligned against the edges of the paper.
- 4 Make sure the paper tray closes properly.

RESET THE PRINTER

Turn the printer off, wait about 10 seconds, and then turn the printer on.

MAKE SURE THE PAPER TRAY IS INSTALLED CORRECTLY

If the paper tray is listed on the menu settings page, but paper jams when it enters or exits the tray, then it may not be properly installed. Reinstall the paper tray. For more information, see the hardware setup documentation that came with the paper tray, or go to www.lexmark.com/publications to view the paper tray instruction sheet.

Paper jam message remains after jam is cleared



CHECK THE PAPER PATH

The paper path is not clear. Clear jammed paper from the entire paper path, and then touch **Continue**.

Page that jammed does not reprint after you clear the jam

TURN ON JAM RECOVERY

In the Setup menu, Jam Recovery is set to Off. Set Jam Recovery to Auto or On:



- 1 Make sure the printer is on and **Ready** appears.
- 2 On the home screen, touch .
- 3 Touch **Settings**.
- 4 Touch **General Settings**.
- 5 Touch the down arrow until **Print Recovery** appears.
- 6 Touch **Print Recovery**.
- 7 Touch the right arrow next to **Jam Recovery** until **On** or **Auto** appears.
- 8 Touch **Submit**.
- 9 Touch .

Solving print quality problems

The information in the following topics may help you solve print quality problems. If these suggestions still do not correct the problem, contact Customer Support. You may have a printer part that requires adjustment or replacement.

Isolating print quality problems

To help isolate print quality problems, print the print quality test pages:

- 1 Turn the printer off.
- 2 Load Letter- or A4-size paper in the tray.
- 3 Hold down  and  while turning the printer on.
- 4 Release the buttons when the screen with the progress bar appears.
The printer performs a power-on sequence, and then the Configuration menu appears.
- 5 Touch the down arrow until **Print Quality Pages** appears.
- 6 Touch **Print Quality Pages**.
The print quality test pages print.
- 7 Touch **Back**.
- 8 Touch **Exit Configuration**.

Blank pages

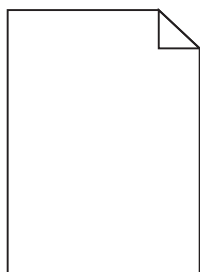

These are possible solutions. Try one or more of the following:

PACKING MATERIAL MAY BE ON THE TONER CARTRIDGE

Remove the toner cartridge and make sure the packing material is properly removed. Reinstall the toner cartridge.

THE TONER MAY BE LOW

When **88 Cartridge low** appears, order a new toner cartridge.

If the problem continues, the printer may need to be serviced. For more information, contact Customer Support.

Characters have jagged or uneven edges

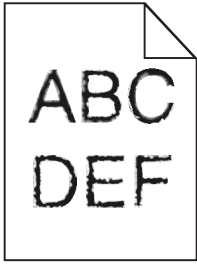

These are possible solutions. Try one or more of the following:

CHECK THE PRINT QUALITY SETTINGS

- Change the Print Resolution setting in the Quality menu to 600 dpi, 1200 Image Q, 1200 dpi, or 2400 Image Q.
- Enable Enhance Fine Lines in the Quality menu.

MAKE SURE DOWNLOADED FONTS ARE SUPPORTED

If you are using downloaded fonts, then verify that the fonts are supported by the printer, the host computer, and the software program.

Clipped images

These are possible solutions. Try one or more of the following:

CHECK THE GUIDES

Move the width and length guides in the tray to the correct positions for the paper size loaded.

CHECK THE PAPER SIZE SETTING

Make sure the paper size setting matches the paper loaded in the tray:

- 1 From the printer control panel Paper menu, check the Paper Size setting.
- 2 Before sending the job to print, specify the correct size setting:
 - For Windows users, specify the size from Print Properties.
 - For Macintosh users, specify the size from the Page Setup or Print dialog.

Ghost images

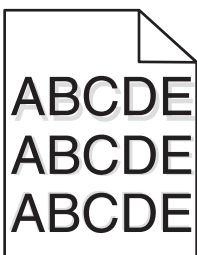

CHECK THE PAPER TYPE SETTING

Make sure the paper type setting matches the paper loaded in the tray:

- 1 From the printer control panel, check the Paper Type setting from the Paper menu.
- 2 Before sending the job to print, specify the correct type setting:
 - For Windows users, specify the type from Print Properties.
 - For Macintosh users, specify the type from the Print dialog.

Gray background

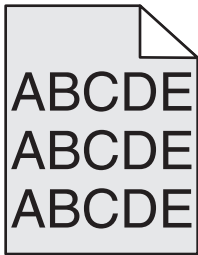

CHECK THE TONER DARKNESS SETTING

Select a lighter Toner Darkness setting:

- From the printer control panel, change the setting from the Quality menu.
- For Windows users, change the setting from Print Properties.
- For Macintosh users, change the setting from the Print dialog.

Incorrect margins

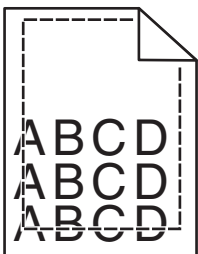

These are possible solutions. Try one or more of the following:

CHECK THE PAPER GUIDES

Move the guides in the tray to the correct positions for the paper size loaded.

CHECK THE PAPER SIZE SETTING

Make sure the paper size setting matches the paper loaded in the tray:

- 1 From the printer control panel Paper menu, check the Paper Size setting.
- 2 Before sending the job to print, specify the correct size setting:
 - For Windows users, specify the size from Print Properties.
 - For Macintosh users, specify the size from the Page Setup or Print dialog.

Paper curl

These are possible solutions. Try one or more of the following:

CHECK THE PAPER TYPE SETTING

Make sure the paper type setting matches the paper loaded in the tray:

- 1 From the printer control panel, check the Paper Type setting from the Paper menu.
- 2 Before sending the job to print, specify the correct type setting:
 - For Windows users, specify the type from Print Properties.
 - For Macintosh users, specify the type from the Print dialog.

THE PAPER HAS ABSORBED MOISTURE DUE TO HIGH HUMIDITY

- Load paper from a fresh package.
- Store paper in its original wrapper until you use it.

Print irregularities

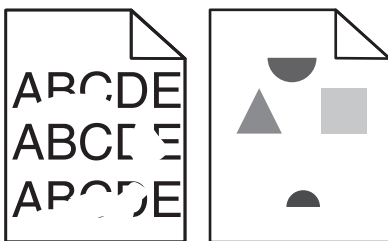

These are possible solutions. Try one or more of the following:

THE PAPER MAY HAVE ABSORBED MOISTURE DUE TO HIGH HUMIDITY

- Load paper from a fresh package.
- Store paper in its original wrapper until you use it.

CHECK THE PAPER TYPE SETTING

Make sure the paper type setting matches the paper loaded in the tray:

- 1 From the printer control panel, check the Paper Type setting from the Paper menu.
- 2 Before sending the job to print, specify the correct type setting:
 - For Windows users, specify the type from Print Properties.
 - For Macintosh users, specify the type from the Print dialog.

CHECK THE PAPER

Avoid textured paper with rough finishes.

THE TONER MAY BE LOW

When **88 Cartridge low** appears or when the print becomes faded, replace the toner cartridge.

THE FUSER MAY BE WORN OR DEFECTIVE

Replace the fuser.

Skewed print

These are possible solutions. Try one or more of the following:

CHECK THE PAPER GUIDES

Move the guides in the tray to the correct positions for the paper size loaded.

CHECK THE PAPER

Make sure you are using paper that meets the printer specifications.

Solid black or white streaks

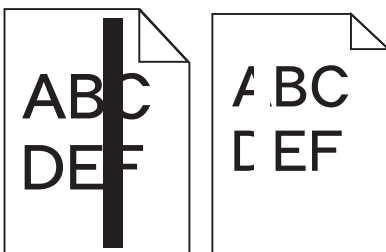

These are possible solutions. Try one or more of the following:

MAKE SURE THE FILL PATTERN IS CORRECT

If the fill pattern is incorrect, then choose a different fill pattern from your software program or application.

CHECK THE PAPER TYPE

- Try a different type of paper.
- Use only transparencies recommended by the printer manufacturer.
- Make sure the Paper Type and Paper Texture settings match the paper loaded in the tray or feeder.

MAKE SURE THE TONER IS DISTRIBUTED EVENLY IN THE PRINT CARTRIDGE

Remove the print cartridge and shake it from side to side to redistribute the toner, and then reinstall it.

THE PRINT CARTRIDGE MAY BE DEFECTIVE OR LOW ON TONER

Replace the used print cartridge with a new one.

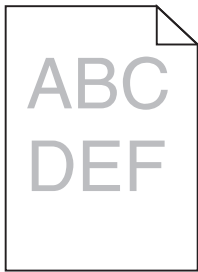
Print is too light

These are possible solutions. Try one or more of the following:

CHECK THE DARKNESS, BRIGHTNESS, AND CONTRAST SETTINGS

The Toner Darkness setting is too light, the Brightness setting is too light, or the Contrast setting is too low.

- From the printer control panel, change these settings from the Quality menu.
- For Windows users, change these settings from Print Properties.
- For Macintosh users, change these settings from the Print dialog and pop-up menus.

THE PAPER HAS ABSORBED MOISTURE DUE TO HIGH HUMIDITY

- Load paper from a fresh package.
- Store paper in its original wrapper until you use it.

CHECK THE PAPER

Avoid textured paper with rough finishes.

CHECK THE PAPER TYPE SETTING

Make sure the paper type setting matches the paper loaded in the tray:

- 1 From the printer control panel, check the Paper Type setting from the Paper menu.
- 2 Before sending the job to print, specify the correct type setting:
 - For Windows users, specify the type from Print Properties.
 - For Macintosh users, specify the type from the Print dialog.

THE TONER IS LOW

When **88 Cartridge Low** appears, order a new toner cartridge.

THE TONER CARTRIDGE MAY BE DEFECTIVE

Replace the toner cartridge.

Print is too dark

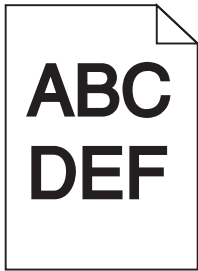

These are possible solutions. Try one or more of the following:

CHECK THE DARKNESS SETTINGS

The Toner Darkness setting is too dark.

- From the printer control panel, change this setting from the Quality menu.
- For Windows users, change this setting from Print Properties.
- For Macintosh users, change this setting from the Print dialog and pop-up menus.

THE PAPER HAS ABSORBED MOISTURE DUE TO HIGH HUMIDITY

- Load paper from a fresh package.
- Store paper in its original wrapper until you use it.

CHECK THE PAPER

Avoid textured paper with rough finishes.

CHECK THE PAPER TYPE SETTING

Make sure the paper type setting matches the paper loaded in the tray:

- 1 From the printer control panel, check the Paper Type setting from the Paper menu.
- 2 Before sending the job to print, specify the correct type setting:
 - For Windows users, specify the type from Print Properties.
 - For Macintosh users, specify the type from the Print dialog.

THE TONER CARTRIDGE MAY BE DEFECTIVE

Replace the toner cartridge.

Streaked vertical lines

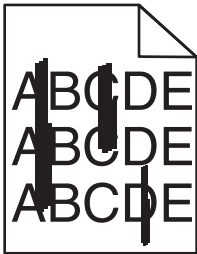

These are possible solutions. Try one or more of the following:

THE TONER IS SMEARED

Select another tray or feeder to feed paper for the job:

- From the printer control panel, select the Default Source from the Paper menu.
- For Windows users, select the paper source from Print Properties.
- For Macintosh users, select the paper source from the Print dialog and pop-up menus.

THE TONER CARTRIDGE IS DEFECTIVE

Replace the toner cartridge.

THE PAPER PATH MAY NOT BE CLEAR

Check the paper path around the toner cartridge.



CAUTION—HOT SURFACE: The inside of the printer might be hot. To reduce the risk of injury from a hot component, allow the surface to cool before touching.

Clear any paper you see.

THERE IS TONER IN THE PAPER PATH

Contact Customer Support.

Toner fog or background shading appears on the page

These are possible solutions. Try one or more of the following:

THE TONER CARTRIDGE MAY BE DEFECTIVE

Replace the toner cartridge.

THE CHARGE ROLLS MAY BE DEFECTIVE

Replace the charge rolls.

THERE IS TONER IN THE PAPER PATH

Contact Customer Support.

Toner rubs off

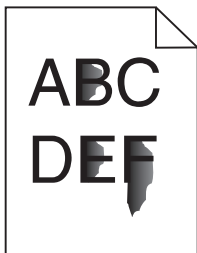

These are possible solutions. Try one or more of the following:

CHECK THE PAPER TYPE SETTING

Make sure the paper type setting matches the paper loaded in the tray:

- 1 From the printer control panel, check the Paper Type setting from the Paper menu.
- 2 Before sending the job to print, specify the correct type setting:
 - For Windows users, specify the type from Print Properties.
 - For Macintosh users, specify the type from the Print dialog.

CHECK THE PAPER TEXTURE SETTING

From the printer control panel Paper menu, make sure the Paper Texture setting matches the paper loaded in the tray.

Toner specks

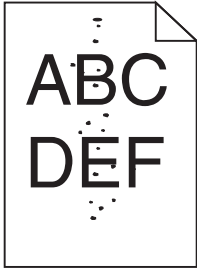

These are possible solutions. Try one or more of the following:

THE TONER CARTRIDGE MAY BE DEFECTIVE

Replace the toner cartridge.

THERE IS TONER IN THE PAPER PATH

Contact Customer Support.

Transparency print quality is poor

Try one or more of the following:

CHECK THE TRANSPARENCIES

Use only transparencies recommended by the printer manufacturer.

CHECK THE PAPER TYPE SETTING

Make sure the paper type setting matches the paper loaded in the tray:

- 1 From the printer control panel, check the Paper Type setting from the Paper menu.
- 2 Before sending the job to print, specify the correct type setting:
 - For Windows users, specify the type from Print Properties.
 - For Macintosh users, specify the type from the Print dialog.

Embedded Web Server does not open

These are possible solutions. Try one or more of the following:

CHECK THE NETWORK CONNECTIONS

Make sure the printer and computer are turned on and connected to the same network.

CHECK THE NETWORK SETTINGS

Depending on the network settings, you may need to type `https://` instead of `http://` before the printer IP address to access the Embedded Web Server. For more information, see your system administrator.

Contacting Customer Support

When you call Customer Support, describe the problem you are experiencing, the message on the display, and the troubleshooting steps you have already taken to find a solution.

You need to know your printer model type and serial number. For more information, see the label on the inside of the front door of the printer. The serial number is also listed on the menu settings page.

In the U.S. or Canada, call (1-800-539-6275). For other countries/regions, visit the Lexmark Web site at www.lexmark.com.

Notices

Product information

Product name:

Lexmark X463de, Lexmark X464de, Lexmark X466dte, Lexmark X466dtwe

Machine type:

7014, 4569, 4570

Model(s):

431, 636, 63W, n01, n02, g01, g02, n11, n12, g11, g12, hn1, hn2, wh1, wh2

Edition notice

August 2011

The following paragraph does not apply to any country where such provisions are inconsistent with local law:

LEXMARK INTERNATIONAL, INC., PROVIDES THIS PUBLICATION "AS IS" WITHOUT WARRANTY OF ANY KIND, EITHER EXPRESS OR IMPLIED, INCLUDING, BUT NOT LIMITED TO, THE IMPLIED WARRANTIES OF MERCHANTABILITY OR FITNESS FOR A PARTICULAR PURPOSE. Some states do not allow disclaimer of express or implied warranties in certain transactions; therefore, this statement may not apply to you.

This publication could include technical inaccuracies or typographical errors. Changes are periodically made to the information herein; these changes will be incorporated in later editions. Improvements or changes in the products or the programs described may be made at any time.

References in this publication to products, programs, or services do not imply that the manufacturer intends to make these available in all countries in which it operates. Any reference to a product, program, or service is not intended to state or imply that only that product, program, or service may be used. Any functionally equivalent product, program, or service that does not infringe any existing intellectual property right may be used instead. Evaluation and verification of operation in conjunction with other products, programs, or services, except those expressly designated by the manufacturer, are the user's responsibility.

For Lexmark technical support, visit support.lexmark.com.

For information on supplies and downloads, visit www.lexmark.com.

If you don't have access to the Internet, you can contact Lexmark by mail:

Lexmark International, Inc.
Bldg 004-2/CSC
740 New Circle Road NW
Lexington, KY 40550
USA

© 2009 Lexmark International, Inc.

All rights reserved.

UNITED STATES GOVERNMENT RIGHTS

This software and any accompanying documentation provided under this agreement are commercial computer software and documentation developed exclusively at private expense.

Trademarks

Lexmark, Lexmark with diamond design, MarkNet, and MarkVision are trademarks of Lexmark International, Inc., registered in the United States and/or other countries.

MarkTrack and PrintCryption are trademarks of Lexmark International, Inc.

PCL® is a registered trademark of the Hewlett-Packard Company. PCL is Hewlett-Packard Company’s designation of a set of printer commands (language) and functions included in its printer products. This printer is intended to be compatible with the PCL language. This means the printer recognizes PCL commands used in various application programs, and that the printer emulates the functions corresponding to the commands.

The following terms are trademarks or registered trademarks of these companies:

Albertus	The Monotype Corporation plc
Antique Olive	Monsieur Marcel OLIVE
Apple-Chancery	Apple Computer, Inc.
Arial	The Monotype Corporation plc
CG Times	Based on Times New Roman under license from The Monotype Corporation plc, is a product of Agfa Corporation
Chicago	Apple Computer, Inc.
Clarendon	Linotype-Hell AG and/or its subsidiaries
Eurostile	Nebiolo
Geneva	Apple Computer, Inc.
Gillsans	The Monotype Corporation plc
Helvetica	Linotype-Hell AG and/or its subsidiaries
Hoefler	Jonathan Hoefler Type Foundry
ITC Avant Garde Gothic	International Typeface Corporation
ITC Bookman	International Typeface Corporation
ITC Mona Lisa	International Typeface Corporation
ITC Zapf Chancery	International Typeface Corporation
Joanna	The Monotype Corporation plc
Marigold	Arthur Baker
Monaco	Apple Computer, Inc.
New York	Apple Computer, Inc.
Oxford	Arthur Baker
Palatino	Linotype-Hell AG and/or its subsidiaries

Stempel Garamond	Linotype-Hell AG and/or its subsidiaries
Taffy	Agfa Corporation
Times New Roman	The Monotype Corporation plc
Univers	Linotype-Hell AG and/or its subsidiaries

All other trademarks are the property of their respective owners.

Federal Communications Commission (FCC) compliance information statement

This product has been tested and found to comply with the limits for a Class B digital device, pursuant to Part 15 of the FCC Rules. Operation is subject to the following two conditions: (1) this device may not cause harmful interference, and (2) this device must accept any interference received, including interference that may cause undesired operation.

The FCC Class B limits are designed to provide reasonable protection against harmful interference when the equipment is operated in a residential installation. This equipment generates, uses, and can radiate radio frequency energy and, if not installed and used in accordance with the instructions, may cause harmful interference to radio communications. However, there is no guarantee that interference will not occur in a particular installation. If this equipment does cause harmful interference to radio or television reception, which can be determined by turning the equipment off and on, the user is encouraged to try to correct the interference by one or more of the following measures:

- Reorient or relocate the receiving antenna.
- Increase the separation between the equipment and receiver.
- Connect the equipment into an outlet on a circuit different from that to which the receiver is connected.
- Consult your point of purchase or service representative for additional suggestions.

The manufacturer is not responsible for radio or television interference caused by using other than recommended cables or by unauthorized changes or modifications to this equipment. Unauthorized changes or modifications could void the user's authority to operate this equipment.

Note: To assure compliance with FCC regulations on electromagnetic interference for a Class B computing device, use a properly shielded and grounded cable such as Lexmark part number 1021231 for parallel attach or 1021294 for USB attach. Use of a substitute cable not properly shielded and grounded may result in a violation of FCC regulations.

Any questions regarding this compliance information statement should be directed to:

Director of Lexmark Technology & Services
 Lexmark International, Inc.
 740 West New Circle Road
 Lexington, KY 40550
 (859) 232-3000

Noise emission levels

The following measurements were made in accordance with ISO 7779 and reported in conformance with ISO 9296.

Note: Some modes may not apply to your product.

1-meter average sound pressure, dBA	
Printing	53 dBA
Scanning	49 dBA
Copying	53 dBA
Ready	22 dBA

Values are subject to change. See www.lexmark.com for current values.

Temperature information

Ambient temperature	15.6C° – 32.2C°
Shipping and storage temperature	-40.0C° – 60.0C°

Waste from Electrical and Electronic Equipment (WEEE) directive



The WEEE logo signifies specific recycling programs and procedures for electronic products in countries of the European Union. We encourage the recycling of our products. If you have further questions about recycling options, visit the Lexmark Web site at www.lexmark.com for your local sales office phone number.

Mercury statement

This product contains mercury in the lamp (<5mg Hg). Disposal of mercury may be regulated due to environmental considerations. For disposal or recycling information, contact your local authorities or the Electronic Industries Alliance: www.eiae.org.

Static sensitivity notice



This symbol identifies static-sensitive parts. Do not touch in the areas near these symbols without first touching the metal frame of the printer.

ENERGY STAR

Any Lexmark product bearing the ENERGY STAR emblem on the product or on a start-up screen is certified to comply with Environmental Protection Agency (EPA) ENERGY STAR requirements as configured when shipped by Lexmark.



Laser notice

The printer is certified in the U.S. to conform to the requirements of DHHS 21 CFR Subchapter J for Class I (1) laser products, and elsewhere is certified as a Class I laser product conforming to the requirements of IEC 60825-1.

Class I laser products are not considered to be hazardous. The printer contains internally a Class IIIb (3b) laser that is nominally a 7 milliwatt gallium arsenide laser operating in the wavelength of 655-675 nanometers. The laser system and printer are designed so there is never any human access to laser radiation above a Class I level during normal operation, user maintenance, or prescribed service condition.

Laser advisory label

A laser notice label may be affixed to this printer as shown:

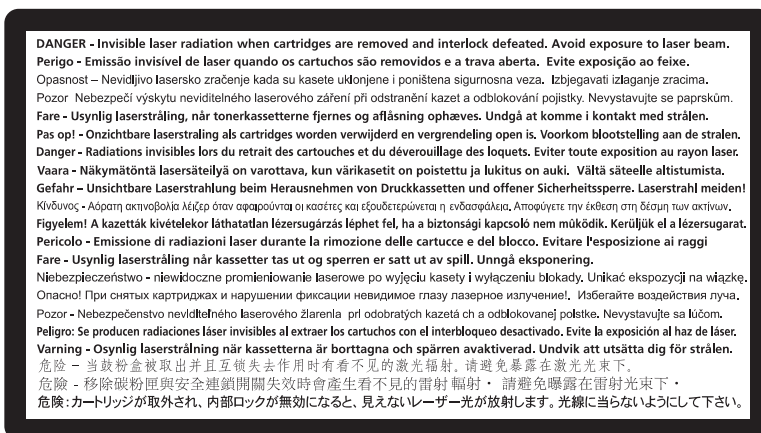

Power consumption

Product power consumption

The following table documents the power consumption characteristics of the product.

Note: Some modes may not apply to your product.

Mode	Description	Power consumption (Watts)
Printing	The product is generating hard-copy output from electronic inputs.	540 W
Copying	The product is generating hard-copy output from hard-copy original documents.	560 W
Scanning	The product is scanning hard-copy documents.	55 W
Ready	The product is waiting for a print job.	45 W
Power Saver	The product is in energy-saving mode.	25 W
Off	The product is plugged into a wall outlet, but the power switch is turned off.	0 W

The power consumption levels listed in the previous table represent time-averaged measurements. Instantaneous power draws may be substantially higher than the average.

Values are subject to change. See www.lexmark.com for current values.

Power Saver

This product is designed with an energy-saving mode called Power Saver. The Power Saver Mode is equivalent to the Sleep Mode. The Power Saver Mode saves energy by lowering power consumption during extended periods of inactivity. The Power Saver Mode is automatically engaged after this product is not used for a specified period of time, called the Power Saver Timeout.

Factory default Power Saver Timeout for this product (in minutes):	30 minutes
--	------------

By using the configuration menus, the Power Saver Timeout can be modified between 1 minute and 240 minutes. Setting the Power Saver Timeout to a low value reduces energy consumption, but may increase the response time of the product. Setting the Power Saver Timeout to a high value maintains a fast response, but uses more energy.

Off mode

If this product has an off mode which still consumes a small amount of power, then to completely stop product power consumption, disconnect the power supply cord from the wall outlet.

Total energy usage

It is sometimes helpful to calculate the total product energy usage. Since power consumption claims are provided in power units of Watts, the power consumption should be multiplied by the time the product spends in each mode in order to calculate energy usage. The total product energy usage is the sum of each mode's energy usage.

European Community (EC) directives conformity

This product is in conformity with the protection requirements of EC Council directives 2004/108/EC and 2006/95/EC on the approximation and harmonization of the laws of the Member States relating to electromagnetic compatibility and safety of electrical equipment designed for use within certain voltage limits.

A declaration of conformity with the requirements of the directives has been signed by the Director of Manufacturing and Technical Support, Lexmark International, Inc., S.A., Boigny, France.

This product satisfies the Class B limits of EN 55022 and safety requirements of EN 60950.

Industry Canada compliance statement

This Class B digital apparatus meets all requirements of the Canadian Interference-Causing Equipment Standard ICES-003.

Avis de conformité aux normes de l'industrie du Canada

Cet appareil numérique de classe B est conforme aux exigences de la norme canadienne relative aux équipements pouvant causer des interférences NMB-003.

Regulatory notices for telecommunication terminal equipment

This section contains regulatory information pertaining to products that contain telecommunication terminal equipment such as facsimile.

Notice to users of the US telephone network: FCC requirements

This equipment complies with Part 68 of the FCC rules and the requirements adopted by the Administrative Council for Terminal Attachments (ACTA). On the back of this equipment is a label that contains, among other information, a product identifier in the format US:AAAEQ##TXXXX. If requested, this number must be provided to your telephone company.

This equipment uses the RJ-11C Universal Service Order Code (USOC) jack.

A plug and jack used to connect this equipment to the premises' wiring and telephone network must comply with the applicable FCC Part 68 rules and requirements adopted by the ACTA. A compliant telephone cord and modular plug is provided with this product. It is designed to be connected to a compatible modular jack that is also compliant. See your setup documentation for more information.

The Ringer Equivalence Number (REN) is used to determine the number of devices that may be connected to a telephone line. Excessive RENs on a telephone line may result in the devices not ringing in response to an incoming call. In most but not all areas, the sum of RENs should not exceed five (5.0). To be certain of the number of devices that may be connected to a line, as determined by the total RENs, contact your local telephone company. For products approved after July 23, 2001, the REN for this product is part of the product identifier that has the format US:AAAEQ##TXXXX. The digits represented by ## are the REN without a decimal point (for example, 03 is a REN of 0.3). For earlier products, the REN is shown separately on the label.

If this equipment causes harm to the telephone network, the telephone company will notify you in advance that temporary discontinuance of service may be required. If advance notice is not practical, the telephone company will notify the customer as soon as possible. You will also be advised of your right to file a complaint with the FCC.

The telephone company may make changes in its facilities, equipment, operations or procedures that could affect the operation of this equipment. If this happens, the telephone company will provide advance notice in order for you to make necessary modifications to maintain uninterrupted service.

If you experience trouble with this equipment, for repair or warranty information, contact Lexmark International, Inc. at www.lexmark.com or your Lexmark representative. If the equipment is causing harm to the telephone network, the telephone company may request that you disconnect the equipment until the problem is resolved.

This equipment contains no user serviceable parts. For repair and warranty information, contact Lexmark International, Inc. See the previous paragraph for contact information.

Connection to party line service is subject to state tariffs. Contact the state public utility commission, public service commission, or corporation commission for information.

If your home has specially wired alarm equipment connected to the telephone line, ensure the installation of this equipment does not disable your alarm equipment. If you have questions about what will disable alarm equipment, consult your telephone company or a qualified installer.

Telephone companies report that electrical surges, typically lightning transients, are very destructive to customer terminal equipment connected to AC power sources. This has been identified as a major nationwide problem. It is recommended that the customer install an appropriate AC surge arrester in the AC outlet to which this device is connected. An appropriate AC surge arrester is defined as one that is suitably rated, and certified by UL (Underwriter's Laboratories), another NRTL (Nationally Recognized Testing Laboratory), or a recognized safety certification body in the country/region of use. This is to avoid damage to the equipment caused by local lightning strikes and other electrical surges.

The Telephone Consumer Protection Act of 1991 makes it unlawful for any person to use a computer or other electronic device, including fax machines, to send any message unless said message clearly contains in a margin at the top or bottom of each transmitted page or on the first page of the transmission, the date and time it is sent and an identification of the business or other entity, or other individual sending the message, and the telephone number of the sending machine or such business, other entity, or individual. (The telephone number provided may not be a 900 number or any other number for which charges exceed local or long-distance transmission charges.)

See your user documentation in order to program this information into your fax machine.

South Africa telecommunications notice

This modem must be used in conjunction with an approved surge protection device when connected to the PSTN.

Notice to users of the Canadian telephone network

This product meets the applicable Industry Canada technical specifications. The Ringer Equivalence Number (REN) is an indication of the maximum number of terminals allowed to be connected to a telephone interface. The terminus of an interface may consist of any combination of devices, subject only to the requirement that the sum of the RENs of all the devices does not exceed five. The modem REN is located on the rear of the equipment on the product labeling.

Telephone companies report that electrical surges, typically lightning transients, are very destructive to customer terminal equipment connected to AC power sources. This has been identified as a major nationwide problem. It is recommended that the customer install an appropriate AC surge arrester in the AC outlet to which this device is connected. An appropriate AC surge arrester is defined as one that is suitably rated, and certified by UL (Underwriter's Laboratories), another NRTL (Nationally Recognized Testing Laboratory), or a recognized safety certification body in the country/region of use. This is to avoid damage to the equipment caused by local lightning strikes and other electrical surges.

This equipment uses CA11A telephone jacks.

Avis réservé aux utilisateurs du réseau téléphonique du Canada

Ce produit est conforme aux spécifications techniques d'Industrie Canada. Le numéro REN (ringer equivalence number : numéro d'équivalence de sonnerie) fournit une indication du nombre maximum de terminaux pouvant être connectés à l'interface téléphonique. En bout de ligne, le nombre d'appareils qui peuvent être connectés n'est pas directement limité, mais la somme des REN de ces appareils ne doit pas dépasser cinq. Le numéro REN du modem est indiqué sur l'étiquette produit située à l'arrière de l'équipement.

Les compagnies de téléphone constatent que les surtensions électriques, en particulier celles dues à la foudre, entraînent d'importants dégâts sur les terminaux privés connectés à des sources d'alimentation CA. Il s'agit-là d'un problème majeur d'échelle nationale. En conséquence, il vous est recommandé de brancher un parasurtenseur dans la prise de courant à laquelle l'équipement est connecté. Utilisez un parasurtenseur répondant à des caractéristiques nominales satisfaisantes et certifié par le laboratoire d'assureurs UL (Underwriter's Laboratories), un autre laboratoire agréé de type NRTL (Nationally Recognized Testing Laboratory) ou un organisme de certification agréé dans votre région ou pays. Ceci prévient tout endommagement de l'équipement causé par les orages et autres surtensions électriques.

Cet équipement utilise des prises de téléphone CA11A.

Notice to users of the New Zealand telephone network

The following are special conditions for the Facsimile User Instructions. The grant of a telepermit for any item of terminal equipment indicates only that Telecom has accepted that the item complies with minimum conditions for connection to its network. It indicates no endorsement of the product by Telecom, nor does it provide any sort of warranty. Above all, it provides no assurance that any item will work correctly in all respects with another item of telepermitted equipment of a different make or model, nor does it imply that any product is compatible with all of Telecom's network services.

This equipment shall not be set up to make automatic calls to the Telecom's 111 Emergency Service.

This equipment may not provide for the effective hand-over of a call to another device connected to the same line.

This equipment should not be used under any circumstances that may constitute a nuisance to other Telecom customers.

Some parameters required for compliance with Telecom's telepermit requirements are dependent on the equipment associated with this device. The associated equipment shall be set to operate within the following limits for compliance to Telecom's specifications:

- There shall be no more than 10 call attempts to the same number within any 30 minute period for any single manual call initiation, and
- The equipment shall go on-hook for a period of not less than 30 seconds between the end of one attempt and the beginning of the next call attempt.
- The equipment shall be set to ensure that automatic calls to different numbers are spaced such that there is not less than 5 seconds between the end of one call attempt and the beginning of another.

Using this product in Switzerland

This product requires a Swiss billing tone filter (Lexmark part number 14B5109 or 80D1877) to be installed on any line which receives metering pulses in Switzerland. The Lexmark filter must be used, as metering pulses are present on all analog telephone lines in Switzerland.

Utilisation de ce produit en Suisse

Cet appareil nécessite l'utilisation d'un filtre de tonalité de facturation suisse (n° de référence Lexmark : 14B5109 ou 80D1877) devant être installé sur toute ligne recevant des impulsions de comptage en Suisse. Ce filtre doit être utilisé pour toute installation car ces impulsions existent sur toutes les lignes téléphoniques suisses.

Verwendung dieses Produkts in der Schweiz

Für dieses Produkt muss ein schweizerischer Billing Tone Filter zur Zählzeichenübertragung (Lexmark Teilenummer 14B5109 oder 80D1877) für jede Leitung installiert werden, über die in der Schweiz Zeitsteuertakte übertragen werden. Die Verwendung des Lexmark Filters ist obligatorisch, da in allen analogen Telefonleitungen in der Schweiz Zeitsteuertakte vorhanden sind.

Usò del prodotto in Svizzera

Questo prodotto richiede un filtro toni Billing svizzero, (codice Lexmark 14B5109 o 80D1877) da installare su tutte le linee che ricevono impulsi remoti in Svizzera. È necessario utilizzare il filtro Lexmark poiché gli impulsi remoti sono presenti su tutte le linee analogiche in Svizzera.

Notice to Users in the European Union

Products bearing the CE mark are in conformity with the protection requirements of EC Council directives 2004/108/EC, 2006/95/EC, and 1999/5/EC on the approximation and harmonization of the laws of the Member States relating to electromagnetic compatibility, safety of electrical equipment designed for use within certain voltage limits and on radio equipment and telecommunications terminal equipment.

Compliance is indicated by the CE marking.



A declaration of conformity with the requirements of the directives is available from the Director of Manufacturing and Technical Support, Lexmark International, S. A., Boigny, France.

Refer to the table at the end of the Notices section for further compliance information.

Regulatory notices for wireless products

This section contains the following regulatory information pertaining to wireless products that contain transmitters, for example, but not limited to, wireless network cards or proximity card readers.

Exposure to radio frequency radiation

The radiated output power of this device is far below the radio frequency exposure limits of the FCC and other regulatory agencies. A minimum separation of 20 cm (8 inches) must be maintained between the antenna and any persons for this device to satisfy the RF exposure requirements of the FCC and other regulatory agencies.

Notice to users in Brazil

Este equipamento opera em caráter secundário, isto é, não tem direito a proteção contra interferência prejudicial, mesmo de estações do mesmo tipo, e não pode causar interferência a sistemas operando em caráter primário. (Res. ANATEL 282/2001).

Industry Canada (Canada)

This device complies with Industry Canada specification RSS-210. Operation is subject to the following two conditions: (1) this device may not cause interference, and (2) this device must accept any interference, including interference that may cause undesired operation of the device.

This device has been designed to operate only with the antenna provided. Use of any other antenna is strictly prohibited per regulations of Industry Canada.

To prevent radio interference to the licensed service, this device is intended to be operated indoors and away from windows to provide maximum shielding. Equipment (or its transmit antenna) that is installed outdoors is subject to licensing.

The installer of this radio equipment must ensure that the antenna is located or pointed such that it does not emit RF fields in excess of Health Canada limits for the general population; consult Safety Code 6, obtainable from Health Canada's Web site www.hc-sc.gc.ca/rpb.

The term "IC:" before the certification/registration number only signifies that the Industry Canada technical specifications were met.

Industry Canada (Canada)

Cet appareil est conforme à la norme RSS-210 d'Industry Canada. Son fonctionnement est soumis aux deux conditions suivantes :

(1) cet appareil ne doit pas provoquer d'interférences et (2) il doit accepter toute interférence reçue, y compris celles risquant d'altérer son fonctionnement.

Cet appareil a été conçu pour fonctionner uniquement avec l'antenne fournie. L'utilisation de toute autre antenne est strictement interdite par la réglementation d'Industry Canada.

En application des réglementations d'Industry Canada, l'utilisation d'une antenne de gain supérieur est strictement interdite.

Pour empêcher toute interférence radio au service faisant l'objet d'une licence, cet appareil doit être utilisé à l'intérieur et loin des fenêtres afin de garantir une protection optimale.

Si le matériel (ou son antenne d'émission) est installé à l'extérieur, il doit faire l'objet d'une licence.

L'installateur de cet équipement radio doit veiller à ce que l'antenne soit implantée et dirigée de manière à n'émettre aucun champ HF dépassant les limites fixées pour l'ensemble de la population par Santé Canada. Reportez-vous au Code de sécurité 6 que vous pouvez consulter sur le site Web de Santé Canada www.hc-sc.gc.ca/rpb.

Le terme « IC » précédant le numéro de d'accréditation/inscription signifie simplement que le produit est conforme aux spécifications techniques d'Industry Canada.

Taiwan NCC RF notice statement

NCC型式認證設備注意事項 台灣低功率射頻電機設備之使用注意事項

經型式認證合格之低功率射頻電機，非經許可，公司、商號或使用者均不得擅自變更頻率、加大功率或變更原設計之特性及功能。

低功率射頻電機之使用不得影響飛航安全及干擾合法通信；經發現有干擾現象時，應立即停用，並改善至無干擾時方得繼續使用。前項合法通信，指依電信規定作業之無線電通信。低功率射頻電機須忍受合法通信或工業、科學及醫療用電波輻射性電機設備之干擾。

Notice to users in the European Union

Products bearing the CE mark are in conformity with the protection requirements of EC Council directives 2004/108/EC, 2006/95/EC, and 1999/5/EC on the approximation and harmonization of the laws of the Member States relating to electromagnetic compatibility, safety of electrical equipment designed for use within certain voltage limits and on radio equipment and telecommunications terminal equipment.

Compliance is indicated by the CE marking.



A declaration of conformity with the requirements of the directives is available from the Director of Manufacturing and Technical Support, Lexmark International, S. A., Boigny, France. Refer to the table at the end of the Notices section for further compliance information.

Products equipped with 2.4GHz Wireless LAN option are in conformity with the protection requirements of EC Council directives 2004/108/EC, 2006/95/EC, and 1999/5/EC on the approximation and harmonization of the laws of the Member States relating to electromagnetic compatibility, safety of electrical equipment designed for use within certain voltage limits and on radio equipment and telecommunications terminal equipment.

Compliance is indicated by the CE marking.



Operation is allowed in all EU and EFTA countries, but is restricted to indoor use only.

A declaration of conformity with the requirements of the directives is available from the Director of Manufacturing and Technical Support, Lexmark International, S. A., Boigny, France. Refer to the table at the end of the Notices section for further compliance information.

Česky	Společnost Lexmark International, Inc. tímto prohlašuje, že výrobek tento výrobek je ve shodě se základními požadavky a dalšími příslušnými ustanoveními směrnice 1999/5/ES.
Dansk	Lexmark International, Inc. erklærer herved, at dette produkt overholder de væsentlige krav og øvrige relevante krav i direktiv 1999/5/EF.
Deutsch	Hiermit erklärt Lexmark International, Inc., dass sich das Gerät dieses Gerät in Übereinstimmung mit den grundlegenden Anforderungen und den übrigen einschlägigen Bestimmungen der Richtlinie 1999/5/EG befindet.
Ελληνική	ΜΕ ΤΗΝ ΠΑΡΟΥΣΑ Η LEXMARK INTERNATIONAL, INC. ΔΗΛΩΝΕΙ ΟΤΙ ΑΥΤΟ ΤΟ ΠΡΟΪΟΝ ΣΥΜΜΟΡΦΩΝΕΤΑΙ ΠΡΟΣ ΤΙΣ ΟΥΣΙΩΔΕΙΣ ΑΠΑΙΤΗΣΕΙΣ ΚΑΙ ΤΙΣ ΛΟΙΠΕΣ ΣΧΕΤΙΚΕΣ ΔΙΑΤΑΞΕΙΣ ΤΗΣ ΟΔΗΓΙΑΣ 1999/5/ΕΚ.
English	Hereby, Lexmark International, Inc., declares that this type of equipment is in compliance with the essential requirements and other relevant provisions of Directive 1999/5/EC.
Español	Por medio de la presente, Lexmark International, Inc. declara que este producto cumple con los requisitos esenciales y cualesquiera otras disposiciones aplicables o exigibles de la Directiva 1999/5/CE.
Eesti	Käesolevaga kinnitab Lexmark International, Inc., et seade see toode vastab direktiivi 1999/5/EÜ põhinõuetele ja nimetatud direktiivist tulenevatele muudele asjakohastele sätetele.

Suomi	Lexmark International, Inc. vakuuttaa täten, että tämä tuote on direktiivin 1999/5/EY oleellisten vaatimusten ja muiden sitä koskevien direktiivin ehtojen mukainen.
Français	Par la présente, Lexmark International, Inc. déclare que l'appareil ce produit est conforme aux exigences fondamentales et autres dispositions pertinentes de la directive 1999/5/CE.
Magyar	Alulírott, Lexmark International, Inc. nyilatkozom, hogy a termék megfelel a vonatkozó alapvető követelményeknek és az 1999/5/EC irányelv egyéb előírásainak.
Íslenska	Hér með lýsir Lexmark International, Inc. yfir því að þessi vara er í samræmi við grunnkröfur og aðrar kröfur, sem gerðar eru í tilskipun 1999/5/EC.
Italiano	Con la presente Lexmark International, Inc. dichiara che questo prodotto è conforme ai requisiti essenziali ed alle altre disposizioni pertinenti stabilite dalla direttiva 1999/5/CE.
Latviski	Ar šo Lexmark International, Inc. deklarē, ka šis izstrādājums atbilst Direktīvas 1999/5/EK būtiskajām prasībām un citiem ar to saistītajiem noteikumiem.
Lietuvių	Šiuo Lexmark International, Inc. deklaruoją, kad šis produktas atitinka esminius reikalavimus ir kitas 1999/5/EB direktyvos nuostatas.
Malti	Bil-preżenti, Lexmark International, Inc., jiddikjara li dan il-prodott huwa konformi mal-ftigijiet essenzjali u ma dispozizzjonijiet oħrajn relevanti li jinsabu fid-Direttiva 1999/5/KE.
Nederlands	Hierbij verklaart Lexmark International, Inc. dat het toestel dit product in overeenstemming is met de essentiële eisen en de andere relevante bepalingen van richtlijn 1999/5/EG.
Norsk	Lexmark International, Inc. erklærer herved at dette produktet er i samsvar med de grunnleggende krav og øvrige relevante krav i direktiv 1999/5/EF.
Polski	Niniejszym Lexmark International, Inc. oświadcza, że niniejszy produkt jest zgodny z zasadniczymi wymogami oraz pozostałymi stosownymi postanowieniami Dyrektywy 1999/5/EC.
Português	A Lexmark International Inc. declara que este produto está conforme com os requisitos essenciais e outras disposições da Diretiva 1999/5/CE.
Slovensky	Lexmark International, Inc. týmto vyhlasuje, že tento produkt spĺňa základné požiadavky a všetky príslušné ustanovenia smernice 1999/5/ES.
Slovensko	Lexmark International, Inc. izjavlja, da je ta izdelek v skladu z bistvenimi zahtevami in ostalimi relevantnimi določili direktive 1999/5/ES.
Svenska	Härmed intygar Lexmark International, Inc. att denna produkt står i överensstämmelse med de väsentliga egenskapskrav och övriga relevanta bestämmelser som framgår av direktiv 1999/5/EG.

Statement of Limited Warranty

Lexmark X463de, Lexmark X464de, Lexmark X466dte, Lexmark X466dtwe

Lexmark International, Inc., Lexington, KY

This limited warranty applies to the United States and Canada. For customers outside the U.S., refer to the country-specific warranty information that came with your product.

This limited warranty applies to this product only if it was originally purchased for your use, and not for resale, from Lexmark or a Lexmark Remarketer, referred to in this statement as “Remarketer.”

Limited warranty

Lexmark warrants that this product:

- Is manufactured from new parts, or new and serviceable used parts, which perform like new parts
- Is, during normal use, free from defects in material and workmanship

If this product does not function as warranted during the warranty period, contact a Remarketer or Lexmark for repair or replacement (at Lexmark's option).

If this product is a feature or option, this statement applies only when that feature or option is used with the product for which it was intended. To obtain warranty service, you may be required to present the feature or option with the product.

If you transfer this product to another user, warranty service under the terms of this statement is available to that user for the remainder of the warranty period. You should transfer proof of original purchase and this statement to that user.

Limited warranty service

The warranty period starts on the date of original purchase as shown on the purchase receipt and ends 12 months later provided that the warranty period for any supplies and for any maintenance items included with the printer shall end earlier if it, or its original contents, are substantially used up, depleted, or consumed.

To obtain warranty service you may be required to present proof of original purchase. You may be required to deliver your product to the Remarketer or Lexmark, or ship it prepaid and suitably packaged to a Lexmark designated location. You are responsible for loss of, or damage to, a product in transit to the Remarketer or the Lexmark designated location.

When warranty service involves the exchange of a product or part, the item replaced becomes the property of the Remarketer or Lexmark. The replacement may be a new or repaired item.

The replacement item assumes the remaining warranty period of the original product.

Replacement is not available to you if the product you present for exchange is defaced, altered, in need of a repair not included in warranty service, damaged beyond repair, or if the product is not free of all legal obligations, restrictions, liens, and encumbrances.

Before you present this product for warranty service, remove all print cartridges, programs, data, and removable storage media (unless directed otherwise by Lexmark).

For further explanation of your warranty alternatives and the nearest Lexmark authorized servicer in your area contact Lexmark on the World Wide Web at www.lexmark.com/support.

Remote technical support is provided for this product throughout its warranty period. For products no longer covered by a Lexmark warranty, technical support may not be available or only be available for a fee.

Extent of limited warranty

Lexmark does not warrant uninterrupted or error-free operation of any product or the durability or longevity of prints produced by any product.

Warranty service does not include repair of failures caused by:

- Modification or unauthorized attachments
- Accidents, misuse, abuse or use inconsistent with Lexmark user's guides, manuals, instructions or guidance
- Unsuitable physical or operating environment

- Maintenance by anyone other than Lexmark or a Lexmark authorized servicer
- Operation of a product beyond the limit of its duty cycle
- Use of printing media outside of Lexmark specifications
- Refurbishment, repair, refilling or remanufacture by a third party of products, supplies or parts
- Products, supplies, parts, materials (such as toners and inks), software, or interfaces not furnished by Lexmark

TO THE EXTENT PERMITTED BY APPLICABLE LAW, NEITHER LEXMARK NOR ITS THIRD PARTY SUPPLIERS OR REMARKETERS MAKE ANY OTHER WARRANTY OR CONDITION OF ANY KIND, WHETHER EXPRESS OR IMPLIED, WITH RESPECT TO THIS PRODUCT, AND SPECIFICALLY DISCLAIM THE IMPLIED WARRANTIES OR CONDITIONS OF MERCHANTABILITY, FITNESS FOR A PARTICULAR PURPOSE, AND SATISFACTORY QUALITY. ANY WARRANTIES THAT MAY NOT BE DISCLAIMED UNDER APPLICABLE LAW ARE LIMITED IN DURATION TO THE WARRANTY PERIOD. NO WARRANTIES, EXPRESS OR IMPLIED, WILL APPLY AFTER THIS PERIOD. ALL INFORMATION, SPECIFICATIONS, PRICES, AND SERVICES ARE SUBJECT TO CHANGE AT ANY TIME WITHOUT NOTICE.

Limitation of liability

Your sole remedy under this limited warranty is set forth in this document. For any claim concerning performance or nonperformance of Lexmark or a Remarketer for this product under this limited warranty, you may recover actual damages up to the limit set forth in the following paragraph.

Lexmark's liability for actual damages from any cause whatsoever will be limited to the amount you paid for the product that caused the damages. This limitation of liability will not apply to claims by you for bodily injury or damage to real property or tangible personal property for which Lexmark is legally liable. **IN NO EVENT WILL LEXMARK BE LIABLE FOR ANY LOST PROFITS, LOST SAVINGS, INCIDENTAL DAMAGE, OR OTHER ECONOMIC OR CONSEQUENTIAL DAMAGES.** This is true even if you advise Lexmark or a Remarketer of the possibility of such damages. Lexmark is not liable for any claim by you based on a third party claim.

This limitation of remedies also applies to claims against any Suppliers and Remarketers of Lexmark. Lexmark's and its Suppliers' and Remarketers' limitations of remedies are not cumulative. Such Suppliers and Remarketers are intended beneficiaries of this limitation.

Additional rights

Some states do not allow limitations on how long an implied warranty lasts, or do not allow the exclusion or limitation of incidental or consequential damages, so the limitations or exclusions contained above may not apply to you.

This limited warranty gives you specific legal rights. You may also have other rights that vary from state to state.

LEXMARK SOFTWARE LIMITED WARRANTY AND LICENSE AGREEMENTS

PLEASE READ CAREFULLY BEFORE USING THIS PRODUCT: BY USING THIS PRODUCT, YOU AGREE TO BE BOUND BY ALL THE TERMS AND CONDITIONS OF THIS SOFTWARE LIMITED WARRANTY AND LICENSE AGREEMENTS. IF YOU DO NOT AGREE WITH THE TERMS OF THIS SOFTWARE LIMITED WARRANTY AND LICENSE AGREEMENTS, PROMPTLY RETURN THE PRODUCT UNUSED AND REQUEST A REFUND OF THE AMOUNT YOU PAID. IF YOU ARE INSTALLING THIS PRODUCT FOR USE BY OTHER PARTIES, YOU AGREE TO INFORM THE USERS THAT USE OF THE PRODUCT INDICATES ACCEPTANCE OF THESE TERMS.

DEVICE LICENSE AGREEMENT

The patented printer is licensed for, and designed to work with only genuine Lexmark toner cartridges and developer components for the life of the patented printer. Under this patent license, you agree to: (1) use only genuine Lexmark

toner cartridges and developer components with this printer except as otherwise provided below, and (2) pass this license/agreement to any subsequent user of this printer. The patented Lexmark toner cartridges and developer components inside are licensed subject to a restriction that they may be used only once. Following their initial use, you agree to return them only to Lexmark for recycling. Lexmark toner cartridges are designed to stop working after a delivering a fixed amount of toner. A variable amount of toner may remain in them when replacement is required. Replacement toner cartridge(s) sold without these terms are available through www.lexmark.com, may be refilled by you, or a third party, as the only cartridge alternative to be used with the licensed printer.

LEXMARK SOFTWARE LICENSE AGREEMENT

This Software License Agreement (“Software License Agreement”) is a legal agreement between you (either an individual or a single entity) and Lexmark International, Inc. (“Lexmark”) that, to the extent your Lexmark product or Software Program is not otherwise subject to a written software license agreement between you and Lexmark or its suppliers, governs your use of any Software Program installed on or provided by Lexmark for use in connection with your Lexmark product. The term “Software Program” includes machine-readable instructions, audio/visual content (such as images and recordings), and associated media, printed materials and electronic documentation, whether incorporated into, distributed with or for use with your Lexmark product.

- 1 STATEMENT OF SOFTWARE LIMITED WARRANTY.** Lexmark warrants that the media (e.g., diskette or compact disk) on which the Software Program (if any) is furnished is free from defects in materials and workmanship under normal use during the warranty period. The warranty period is ninety (90) days and commences on the date the Software Program is delivered to the original end-user. This limited warranty applies only to Software Program media purchased new from Lexmark or an Authorized Lexmark Reseller or Distributor. Lexmark will replace the Software Program should it be determined that the media does not conform to this limited warranty.
- 2 DISCLAIMER AND LIMITATION OF WARRANTIES.** EXCEPT AS PROVIDED IN THIS SOFTWARE LICENSE AGREEMENT AND TO THE MAXIMUM EXTENT PERMITTED BY APPLICABLE LAW, LEXMARK AND ITS SUPPLIERS PROVIDE THE SOFTWARE PROGRAM “AS IS” AND HEREBY DISCLAIM ALL OTHER WARRANTIES AND CONDITIONS, EITHER EXPRESS OR IMPLIED, INCLUDING, BUT NOT LIMITED TO, TITLE, NON-INFRINGEMENT, MERCHANTABILITY AND FITNESS FOR A PARTICULAR PURPOSE, AND ABSENCE OF VIRUSES, ALL WITH REGARD TO THE SOFTWARE PROGRAM. TO THE EXTENT LEXMARK CANNOT BY LAW DISCLAIM ANY COMPONENT OF THE IMPLIED WARRANTIES OF MERCHANTABILITY OR FITNESS FOR A PARTICULAR PURPOSE, LEXMARK LIMITS THE DURATION OF SUCH WARRANTIES TO THE 90-DAY TERM OF THE EXPRESS SOFTWARE LIMITED WARRANTY.

This Agreement is to be read in conjunction with certain statutory provisions, as that may be in force from time to time, that imply warranties or conditions or impose obligations on Lexmark that cannot be excluded or modified. If any such provisions apply, then to the extent Lexmark is able, Lexmark hereby limits its liability for breach of those provisions to one of the following: providing you a replacement copy of the Software Program or reimbursement of the price paid for the Software Program.

The Software Program may include internet links to other software applications and/or internet web pages hosted and operated by third parties unaffiliated with Lexmark. You acknowledge and agree that Lexmark is not responsible in any way for the hosting, performance, operation, maintenance, or content of, such software applications and/or internet web pages.

- 3 LIMITATION OF REMEDY.** TO THE MAXIMUM EXTENT PERMITTED BY APPLICABLE LAW, ANY AND ALL LIABILITY OF LEXMARK UNDER THIS SOFTWARE LICENSE AGREEMENT IS EXPRESSLY LIMITED TO THE GREATER OF THE PRICE PAID FOR THE SOFTWARE PROGRAM AND FIVE U.S. DOLLARS (OR THE EQUIVALENT IN LOCAL CURRENCY). YOUR SOLE REMEDY AGAINST LEXMARK IN ANY DISPUTE UNDER THIS SOFTWARE LICENSE AGREEMENT SHALL BE TO SEEK TO RECOVER ONE OF THESE AMOUNTS, UPON PAYMENT OF WHICH LEXMARK SHALL BE RELEASED AND DISCHARGED OF ALL FURTHER OBLIGATIONS AND LIABILITY TO YOU.

IN NO EVENT WILL LEXMARK, ITS SUPPLIERS, SUBSIDIARIES, OR RESELLERS BE LIABLE FOR ANY SPECIAL, INCIDENTAL, INDIRECT, EXEMPLARY, PUNITIVE, OR CONSEQUENTIAL DAMAGES (INCLUDING BUT NOT LIMITED TO LOST PROFITS OR REVENUES, LOST SAVINGS, INTERRUPTION OF USE OR ANY LOSS OF, INACCURACY IN, OR DAMAGE TO, DATA OR RECORDS, FOR CLAIMS OF THIRD PARTIES, OR DAMAGE TO REAL OR TANGIBLE PROPERTY, FOR LOSS OF PRIVACY

ARISING OUT OR IN ANY WAY RELATED TO THE USE OF OR INABILITY TO USE THE SOFTWARE PROGRAM, OR OTHERWISE IN CONNECTION WITH ANY PROVISION OF THIS SOFTWARE LICENCE AGREEMENT), REGARDLESS OF THE NATURE OF THE CLAIM, INCLUDING BUT NOT LIMITED TO BREACH OF WARRANTY OR CONTRACT, TORT (INCLUDING NEGLIGENCE OR STRICT LIABILITY), AND EVEN IF LEXMARK, OR ITS SUPPLIERS, AFFILIATES, OR REMARKETERS HAVE BEEN ADVISED OF THE POSSIBILITY OF SUCH DAMAGES, OR FOR ANY CLAIM BY YOU BASED ON A THIRD-PARTY CLAIM, EXCEPT TO THE EXTENT THIS EXCLUSION OF DAMAGES IS DETERMINED LEGALLY INVALID. THE FOREGOING LIMITATIONS APPLY EVEN IF THE ABOVE-STATED REMEDIES FAIL OF THEIR ESSENTIAL PURPOSE.

- 4 U.S.A. STATE LAWS.** This Software Limited Warranty gives you specific legal rights. You may also have other rights that vary from state to state. Some states do not allow limitations on how long an implied warranty lasts or the exclusion of limitation of incidental or consequential damages, so the above limitations may not apply to you.
- 5 LICENSE GRANT.** Lexmark grants you the following rights provided you comply with all terms and conditions of this Software License Agreement:
- a Use.** You may Use one (1) copy of the Software Program. The term “Use” means storing, loading, installing, executing, or displaying the Software Program. If Lexmark has licensed the Software Program to you for concurrent use, you must limit the number of authorized users to the number specified in your agreement with Lexmark. You may not separate the components of the Software Program for use on more than one computer. You agree that you will not Use the Software Program, in whole or in part, in any manner that has the effect of overriding, modifying, eliminating, obscuring, altering or de-emphasizing the visual appearance of any trademark, trade name, trade dress or intellectual property notice that appears on any computer display screens normally generated by, or as a result of, the Software Program.
 - b Copying.** You may make one (1) copy of the Software Program solely for purposes of backup, archiving, or installation, provided the copy contains all of the original Software Program’s proprietary notices. You may not copy the Software Program to any public or distributed network.
 - c Reservation of Rights.** The Software Program, including all fonts, is copyrighted and owned by Lexmark International, Inc. and/or its suppliers. Lexmark reserves all rights not expressly granted to you in this Software License Agreement.
 - d Freeware.** Notwithstanding the terms and conditions of this Software License Agreement, all or any portion of the Software Program that constitutes software provided under public license by third parties (“Freeware”) is licensed to you subject to the terms and conditions of the software license agreement accompanying such Freeware, whether in the form of a discrete agreement, shrink-wrap license, or electronic license terms at the time of download or installation. Use of the Freeware by you shall be governed entirely by the terms and conditions of such license.
- 6 TRANSFER.** You may transfer the Software Program to another end-user. Any transfer must include all software components, media, printed materials, and this Software License Agreement and you may not retain copies of the Software Program or components thereof. The transfer may not be an indirect transfer, such as a consignment. Prior to the transfer, the end-user receiving the transferred Software Program must agree to all these Software License Agreement terms. Upon transfer of the Software Program, your license is automatically terminated. You may not rent, sublicense, or assign the Software Program except to the extent provided in this Software License Agreement.
- 7 UPGRADES.** To Use a Software Program identified as an upgrade, you must first be licensed to the original Software Program identified by Lexmark as eligible for the upgrade. After upgrading, you may no longer use the original Software Program that formed the basis for your upgrade eligibility.
- 8 LIMITATION ON REVERSE ENGINEERING.** You may not alter, decrypt, reverse engineer, reverse assemble, reverse compile or otherwise translate the Software Program or assist or otherwise facilitate others to do so, except as and to the extent expressly permitted to do so by applicable law for the purposes of inter-operability, error correction, and security testing. If you have such statutory rights, you will notify Lexmark in writing of any intended reverse engineering, reverse assembly, or reverse compilation. You may not decrypt the Software Program unless necessary for the legitimate Use of the Software Program.

- 9 ADDITIONAL SOFTWARE.** This Software License Agreement applies to updates or supplements to the original Software Program provided by Lexmark unless Lexmark provides other terms along with the update or supplement.
- 10 TERM.** This Software License Agreement is effective unless terminated or rejected. You may reject or terminate this license at any time by destroying all copies of the Software Program, together with all modifications, documentation, and merged portions in any form, or as otherwise described herein. Lexmark may terminate your license upon notice if you fail to comply with any of the terms of this Software License Agreement. Upon such termination, you agree to destroy all copies of the Software Program together with all modifications, documentation, and merged portions in any form.
- 11 TAXES.** You agree that you are responsible for payment of any taxes including, without limitation, any goods and services and personal property taxes, resulting from this Software License Agreement or your Use of the Software Program.
- 12 LIMITATION ON ACTIONS.** No action, regardless of form, arising out of this Software License Agreement may be brought by either party more than two years after the cause of action has arisen, except as provided under applicable law.
- 13 APPLICABLE LAW.** This Software License Agreement is governed by the laws of the Commonwealth of Kentucky, United States of America. No choice of law rules in any jurisdiction shall apply. The UN Convention on Contracts for the International Sale of Goods shall not apply.
- 14 UNITED STATES GOVERNMENT RESTRICTED RIGHTS.** The Software Program has been developed entirely at private expense. Rights of the United States Government to use the Software Program are as set forth in this Software License Agreement and as restricted in DFARS 252.227-7014 and in similar FAR provisions (or any equivalent agency regulation or contract clause).
- 15 CONSENT TO USE OF DATA.** You agree that Lexmark, its affiliates, and agents may collect and use information you provide in relation to support services performed with respect to the Software Program and requested by you. Lexmark agrees not to use this information in a form that personally identifies you except to the extent necessary to provide such services.
- 16 EXPORT RESTRICTIONS.** You may not (a) acquire, ship, transfer, or reexport, directly or indirectly, the Software Program or any direct product therefrom, in violation of any applicable export laws or (b) permit the Software Program to be used for any purpose prohibited by such export laws, including, without limitation, nuclear, chemical, or biological weapons proliferation.
- 17 AGREEMENT TO CONTRACT ELECTRONICALLY.** You and Lexmark agree to form this Software License Agreement electronically. This means that when you click the “Agree” or “I accept” button on this page or use this product, you acknowledge your agreement to these Software License Agreement terms and conditions and that you are doing so with the intent to “sign” a contract with Lexmark.
- 18 CAPACITY AND AUTHORITY TO CONTRACT.** You represent that you are of the legal age of majority in the place you sign this Software License Agreement and, if applicable, you are duly authorized by your employer or principal to enter into this contract.
- 19 ENTIRE AGREEMENT.** This Software License Agreement (including any addendum or amendment to this Software License Agreement that is included with the Software Program) is the entire agreement between you and Lexmark relating to the Software Program. Except as otherwise provided for herein, these terms and conditions supersede all prior or contemporaneous oral or written communications, proposals, and representations with respect to the Software Program or any other subject matter covered by this Software License Agreement (except to the extent such extraneous terms do not conflict with the terms of this Software License Agreement, any other written agreement signed by you and Lexmark relating to your Use of the Software Program). To the extent any Lexmark policies or programs for support services conflict with the terms of this Software License Agreement, the terms of this Software License Agreement shall control.

ADOBE SYSTEMS INCORPORATED NOTICE

Contains Flash®, Flash® Lite™ and/or Reader® technology by Adobe Systems Incorporated

This Product contains Adobe® Flash® player software under license from Adobe Systems Incorporated, Copyright © 1995-2007 Adobe Macromedia Software LLC. All rights reserved. Adobe, Reader and Flash are trademarks of Adobe Systems Incorporated.

Index

Numerics

1565 Emulation error, load emulation option 268
 200–282.yy paper jam 267
 250-sheet drawer installing 49
 290-295.yy scanner jam 267
 293 Replace all originals if restarting job 267
 293.02 Flatbed Cover Open 267
 294 ADF Jam 267
 30 Invalid refill, change toner cartridge 261
 31 Replace defective cartridge 261
 32 Cartridge part number unsupported by device 261
 34 Short paper 261
 35 Insufficient memory to support Resource Save feature 261
 37 Insufficient memory to collate job 261
 37 Insufficient memory, some Held Jobs were deleted 261
 37 Insufficient memory, some held jobs will not be restored 262
 38 Memory full 262
 39 Complex page, some data may not have printed 262
 50 PPDS font error 262
 51 Defective flash detected 262
 52 Not enough free space in flash memory for resources 262
 53 Unformatted flash detected 263
 54 Network <x> software error 263
 54 Serial option <x> error 263
 54 Standard network software error 263
 55 Unsupported option in slot 263
 550-sheet drawer installing 49
 56 Parallel port <x> disabled 264
 56 Serial port <x> disabled 264
 56 Standard parallel port disabled 264
 56 Standard USB port disabled 264
 56 USB port <x> disabled 264
 57 Configuration change, held jobs were not restored 265

58 Too many flash options installed 265
 58 Too many trays attached 265
 59 Incompatible tray <x> 265
 61 Remove defective disk 265
 62 Disk full 266
 63 Unformatted disk 266
 80 Routine maintenance needed 266
 84 PC Kit life warning 266
 84 Replace PC Kit 266
 840.01 Scanner Disabled 268
 841-846 Scanner Service Error 268
 88 Cartridge low 266
 88.yy Cartridge nearly low 266
 88.yy Replace cartridge 266
 900–999 Service <message> 268

A

Active NIC menu 165
 address book, fax using 138
 ADF copying using 102
 ADF pick assembly ordering 235
 ADF separator roll ordering 235
 ADF separator rollers, cleaning 230
 Answering 254
 AppleTalk menu 171
 attaching cables 50

B

brightness, adjusting 70
 buttons, home screen 23
 buttons, printer control panel 22
 buttons, touch screen 24

C

cables
 Ethernet 50
 USB 50
 calling Customer Support 294
 canceling a job
 from Macintosh 100

 from the printer control panel 100
 from Windows 100
 card stock loading 79
 tips 96
 Change <src> to <x> 255
 Check tray <x> connection 255
 checking an unresponsive printer 254
 checking an unresponsive scanner 275
 checking device status
 on Embedded Web Server 237
 cleaning
 ADF separator rollers 230
 exterior of the printer 229
 scanner glass 229
 Close door or insert cartridge 255
 Close front door 255
 collating copies 106
 Confidential print jobs 96
 printing from Macintosh computer 97
 printing from Windows 97
 Confidential Print menu 179
 configuration information
 wireless network 54
 configurations
 printer 17
 Configure MP menu 158
 configuring
 port settings 64
 configuring the e-mail settings 115
 Connect <x>bps 255
 connecting the printer to
 answering machine 124
 computer modem 131
 distinctive ring service 124
 regional adapters 126
 telephone 124
 conservation settings
 brightness, adjusting 70
 Eco-Mode 69
 Power Saver 70
 Quiet Mode 73
 standard exit bin lighting 71
 conserving supplies 68

- contacting Customer Support 294
 - control panel, printer 22
 - copy quality
 - adjusting 105
 - improving 113
 - copy screen
 - options 110, 111
 - Copy Settings menu 189
 - copy troubleshooting
 - copier does not respond 272
 - partial document or photo
 - copies 274
 - poor copy quality 273
 - poor scanned image quality 275
 - scanner unit does not close 272
 - copying
 - adding a date and time stamp 109
 - adding an overlay message 109
 - adjusting quality 105
 - canceling a copy job 109, 110
 - collating copies 106
 - custom job (job build) 107
 - enlarging 105
 - from one size to another 104
 - improving copy quality 113
 - making transparencies 103
 - multiple pages on one sheet 107
 - on both sides of the paper (duplexing) 105
 - pausing a print job to make copies 108
 - photos 103
 - placing separator sheets between copies 106
 - quick copy 102
 - reducing 105
 - selecting a tray 104
 - to letterhead 104
 - using the ADF 102
 - using the scanner glass (flatbed) 103
 - Custom Names menu 162
 - custom paper type
 - assigning 85
 - Custom Scan Sizes menu 162
 - Custom Type <x>
 - changing name 85
 - Custom Types menu 162
- D**
- date and time
 - setting 133
 - Default Source menu 155
 - directory list, printing 99
 - Disk corrupted 256
 - Disk Full - Scan Job Canceled 256
 - Disk Wiping menu 180
 - display troubleshooting
 - display is blank 254
 - display shows only diamonds 254
 - display, printer control panel 22
 - adjusting brightness 70
 - distinctive ring service
 - connecting to 124
 - documents, printing
 - from Macintosh 93
 - from Windows 93
 - duplexing
 - copy jobs 105
 - fax jobs, incoming 140
 - print jobs 93
- E**
- Eco-Mode setting 69
 - Embedded Web Server 237
 - administrator settings 237
 - checking device status 237
 - does not open 293
 - networking settings 237
 - setting up e-mail alerts 237
 - Embedded Web Server Administrator's Guide 237
 - emission
 - notices 297, 300, 301, 304, 305, 306
 - enlarging a copy 105
 - envelopes
 - loading 79
 - tips 94
 - environmental settings
 - brightness, adjusting 70
 - Eco-Mode 69
 - Power Saver 70
 - Quiet Mode 73
 - standard exit bin lighting 71
 - Ethernet networking
 - Macintosh 61
 - Windows 61
 - Ethernet port 50
 - exterior of the printer
 - cleaning 229
 - e-mail
 - canceling 118
 - enabling 114
 - notice of low supply level 237
 - notice of paper jam 237
 - notice of paper needed 237
 - notice that different paper is needed 237
 - e-mail function
 - setting up 115
 - e-mail screen
 - advanced options 120
 - options 118, 119
 - E-mail Settings menu 204
 - e-mailing
 - adding message line 117
 - adding subject line 117
 - changing output file type 118
 - configuring the e-mail settings 115
 - creating shortcuts using the Embedded Web Server 115
 - creating shortcuts using the touch screen 116
 - e-mail setup 114
 - setting up e-mail function 115
 - using shortcut numbers 116
 - using the address book 117
 - using the touch screen 116
- F**
- factory defaults, restoring
 - printer control panel menus 238
 - fax card
 - installing 46
 - fax connection
 - connecting the printer to the wall jack 122
 - connecting to a DSL line 123
 - connecting to a PBX or ISDN 123
 - fax connections
 - answering machine 124
 - computer modem 131
 - distinctive ring service 124
 - regional adapters 126
 - telephone 124
 - Fax failed 256
 - Fax memory full 256
 - Fax Mode (Analog Fax Setup) menu 195
 - Fax Mode (Fax Server Setup) menu 202
 - Fax partition inoperative. Contact system administrator. 256
 - fax quality, improving 143

- fax screen
 - advanced options 142
 - options 141, 142
- Fax server 'To Format' not set up. Contact system administrator. 256
- fax setup 121
- Fax Station Name not set up 256
- Fax Station Number not set up 257
- fax troubleshooting
 - blocking junk faxes 140
 - caller ID is not shown 277
 - can receive but not send faxes 279
 - can send but not receive faxes 279
 - cannot send or receive a fax 277
 - received fax has poor print quality 280
- faxing
 - canceling a fax job 141
 - changing resolution 139
 - choosing a fax connection 121
 - creating shortcuts using the Embedded Web Server 137
 - creating shortcuts using the touch screen 137
 - enabling 132
 - fax setup 121, 132, 133
 - forwarding faxes 144
 - holding faxes 143
 - improving fax quality 143
 - making a fax lighter or darker 139
 - printing on both sides (duplexing) 140
 - sending a fax at a scheduled time 139
 - sending using the computer 134, 136
 - sending using the printer control panel 134
 - setting the date and time 133
 - turning daylight saving time on or off 134
 - using shortcuts 138
 - using the address book 138
 - viewing a fax log 140
- FCC notices 297, 301, 304
- fiber optic
 - network setup 61
- finding
 - information 16
 - publications 16

- Web site 16
- Finishing menu 219
- firmware card
 - installing 33
- flash drive 98
- Flash Drive menu 212
- flash memory card
 - installing 33
 - troubleshooting 281
- font sample list
 - printing 99
- forwarding faxes 144
- FTP
 - address book 146
 - FTP quality, improving 149
 - FTP screen
 - advanced options 148
 - options 147, 148
 - FTP Settings menu 209

G

- green settings
 - brightness, adjusting 70
 - Eco-Mode 69
 - Power Saver 70
 - Quiet Mode 73
 - standard exit bin lighting 71
- guidelines
 - letterhead 94
 - transparencies 94

H

- hard disk with adapter
 - troubleshooting 281
- held jobs 96
 - printing from Macintosh computer 97
 - printing from Windows 97
- Help menu 228
- holding faxes 143
- home screen
 - buttons 23
- how to set up the printer 54
- HTML menu 226

I

- Image menu 227
- information, finding 16
- Insert Tray <x> 257
- Install tray <x> 257

- installation
 - wireless network 55, 58
- installing
 - options in driver 53
 - printer software 52, 135
- installing printer software
 - adding options 53
- Internal Solutions Port
 - installing 35
 - troubleshooting 282
- Internal Solutions Port, network
 - changing port settings 64
- Invalid PIN 257
- IPv6 menu 170

J

- jams
 - accessing 239
 - avoiding 75
 - understanding messages 239
- jams, clearing
 - 200-201 241
 - 202 243
 - 231 244
 - 233 245
 - 234 246
 - 235 246
 - 240-249 246
 - 250 247
 - 251 248
 - 290-294 250

L

- labels, paper
 - tips 95
- letterhead
 - copying to 104
 - loading 79
 - tips on using 94
- LexLink menu 172
- light
 - standard exit bin 71
- light, indicator 22, 254
- linking trays 84
- Load <src> with <x> 257
- Load manual feeder with <x> 258
- loading
 - multipurpose feeder 79
 - trays 75

M

Macintosh
 wireless network installation 58
 memory card
 installing 31
 troubleshooting 282
 Memory full, cannot print
 faxes 258
 menu settings page
 printing 51
 menus
 Active NIC 165
 AppleTalk 171
 Confidential Print 179
 Configure MP 158
 Copy Settings 189
 Custom Names 162
 Custom Scan Sizes 162
 Custom Types 162
 Default Source 155
 diagram of 154
 Disk Wiping 180
 E-mail Settings 204
 Fax Mode (Analog Fax Setup) 195
 Fax Mode (Fax Server Setup) 202
 Finishing 219
 Flash Drive 212
 FTP Settings 209
 Help 228
 HTML 226
 Image 227
 IPv6 170
 LexLink 172
 Miscellaneous 179
 NetWare 171
 Network <x> 165
 Network Card 168
 Network Reports 168
 Paper Loading 160
 Paper Size/Type 155
 Paper Texture 159
 Paper Weight 160
 Parallel <x> menu 174
 PCL Emul 224
 PDF 223
 PostScript 223
 Quality 221
 Reports 164
 Security Audit Log 181
 Serial <x> 176
 Set Date/Time 182

Settings 183
 Setup 217
 SMTP Setup menu 167
 Standard Network 165
 Standard USB 173
 Substitute Size 158
 TCP/IP 169
 Universal Setup 163
 Utilities 222
 Wireless 171
 XPS 228
 Miscellaneous menu 179
 moving the printer 235
 multiple pages on one sheet 107
 multipurpose feeder
 loading 79

N

NetWare menu 171
 Network 258
 Network <x> 258
 Network <x> menu 165
 Network Card menu 168
 Network Reports menu 168
 network setup page 52
 Networking Guide 237
 No analog phone line connected to
 modem, fax is disabled. 258
 No answer 258
 No dial tone 258
 noise
 reducing 73
 noise emission levels 297
 notices 296, 297, 298, 299, 300,
 301, 302, 303, 304, 305, 306

O

options
 250-sheet drawer 49
 550-sheet drawer 49
 fax card 28, 46
 firmware card 28, 33
 flash memory card 33
 internal 28
 Internal Solutions Port 28, 35
 memory card 28, 31
 networking 28
 ports 28
 printer hard disk 28, 42
 options, touch-screen
 copy 110, 111

e-mail 118, 119, 120
 fax 141, 142
 FTP 147, 148
 ordering
 ADF pick assembly 235
 ADF separator roll 235
 ordering supplies 234
 output file type
 changing 118

P

paper
 characteristics 87
 letterhead 89
 loading, multipurpose feeder 79
 preprinted forms 89
 recycled 68, 88
 selecting 88
 setting size 74
 setting type 74
 storing 89
 unacceptable 88
 Universal Paper Size 163
 Universal size setting 74
 paper capacities
 trays 92
 paper capacity
 multipurpose feeder 92
 Paper Change: Load Tray<x> <paper
 type> 258
 paper feed troubleshooting
 message remains after jam is
 cleared 283
 paper jams
 accessing jam areas 239
 avoiding 75
 paper jams, clearing
 200-201 241
 231 244
 233 245
 234 246
 235 246
 240-249 246
 250 247
 251 248
 290-294 250
 paper labels
 loading 79
 Paper Loading menu 160
 Paper Size/Type menu 155
 paper sizes
 supported by the printer 90

- Paper Texture menu 159
 - paper type
 - custom 85
 - paper types
 - duplex support 91
 - supported by printer 91
 - where to load 91
 - Paper Weight menu 160
 - Parallel <x> menu 174
 - pausing the current print job
 - to make copies 108
 - PCL Emul menu 224
 - PDF menu 223
 - photoconductor kit
 - ordering 234
 - photos
 - copying 103
 - port settings
 - configuring 64
 - PostScript menu 223
 - Power Saver
 - adjusting 70
 - print job
 - canceling from Macintosh 100
 - canceling from Windows 100
 - print quality
 - cleaning the scanner glass 229
 - print quality test pages, printing 100
 - print quality troubleshooting
 - blank pages 284
 - characters have jagged edges 285
 - clipped images 285
 - ghost images 285
 - gray background 286
 - poor transparency quality 293
 - print irregularities 287
 - print is too dark 290
 - print is too light 289
 - print quality test pages 284
 - skewed print 288
 - solid black streaks 288
 - solid white streaks 288
 - streaked vertical lines 291
 - toner fog or background shading 292
 - toner rubs off 292
 - toner specks 293
 - print troubleshooting
 - error reading USB drive 269
 - held jobs do not print 270
 - incorrect characters print 271
 - incorrect margins 286
 - jammed page does not reprint 283
 - job prints from wrong tray 271
 - job prints on wrong paper 271
 - job takes longer than expected 270
 - jobs do not print 269
 - Large jobs do not collate 271
 - multiple-language PDFs do not print 268
 - paper curl 287
 - paper frequently jams 282
 - tray linking does not work 271
 - unexpected page breaks occur 272
 - printer
 - configurations 17
 - minimum clearances 19
 - models 17
 - moving 235
 - selecting a location 19
 - shipping 236
 - printer control panel 22
 - factory defaults, restoring 238
 - printer hard disk
 - installing 42
 - printer messages
 - 1565 Emulation error, load emulation option 268
 - 200–282.yy paper jam 267
 - 290–295.yy scanner jam 267
 - 293 Replace all originals if restarting job 267
 - 293.02 Flatbed Cover Open 267
 - 294 ADF Jam 267
 - 30 Invalid refill, change toner cartridge 261
 - 31 Replace defective cartridge 261
 - 32 Cartridge part number unsupported by device 261
 - 34 Short paper 261
 - 35 Insufficient memory to support Resource Save feature 261
 - 37 Insufficient memory to collate job 261
 - 37 Insufficient memory, some Held Jobs were deleted 261
 - 37 Insufficient memory, some held jobs will not be restored 262
 - 38 Memory full 262
 - 39 Complex page, some data may not have printed 262
 - 50 PPDS font error 262
 - 51 Defective flash detected 262
 - 52 Not enough free space in flash memory for resources 262
 - 53 Unformatted flash detected 263
 - 54 Network <x> software error 263
 - 54 Serial option <x> error 263
 - 54 Standard network software error 263
 - 55 Unsupported option in slot 263
 - 56 Parallel port <x> disabled 264
 - 56 Serial port <x> disabled 264
 - 56 Standard parallel port disabled 264
 - 56 Standard USB port disabled 264
 - 56 USB port <x> disabled 264
 - 57 Configuration change, held jobs were not restored 265
 - 58 Too many flash options installed 265
 - 58 Too many trays attached 265
 - 59 Incompatible tray <x> 265
 - 61 Remove defective disk 265
 - 62 Disk full 266
 - 63 Unformatted disk 266
 - 80 Routine maintenance needed 266
 - 84 PC Kit life warning 266
 - 84 Replace PC Kit 266
 - 840.01 Scanner Disabled 268
 - 841-846 Scanner Service Error 268
 - 88 Cartridge low 266
 - 88.yy Cartridge nearly low 266
 - 88.yy Replace cartridge 266
 - 900–999 Service <message> 268
- Answering 254
 - Change <src> to <x> 255
 - Check tray <x> connection 255
 - Close door or insert cartridge 255
 - Close front door 255
 - Connect <x>bps 255
 - Disk corrupted 256
 - Disk Full - Scan Job Canceled 256
 - Fax failed 256
 - Fax memory full 256

- Fax partition inoperative. Contact system administrator. 256
 - Fax server 'To Format' not set up. Contact system administrator. 256
 - Fax Station Name not set up 256
 - Fax Station Number not set up 257
 - Insert Tray <x> 257
 - Install tray <x> 257
 - Invalid PIN 257
 - Load <src>with <x> 257
 - Load manual feeder with <x> 258
 - Memory full, cannot print faxes 258
 - Network 258
 - Network <x> 258
 - No analog phone line connected to modem, fax is disabled. 258
 - No answer 258
 - No dial tone 258
 - Paper Change: Load Tray<x> <paper type> 258
 - Queued for sending 258
 - Remove originals from the scanner ADF 259
 - Remove packaging material, check <x> 259
 - Remove paper from standard output bin 259
 - Replace all originals if restarting job. 259
 - Restore Held Jobs? 259
 - Scan Document Too Long 259
 - Scanner ADF Cover Open 259
 - Securely clearing disk space 259
 - Serial <x> 260
 - Set clock 260
 - SMTP server not set up. Contact system administrator. 260
 - Some held jobs were not restored 260
 - System busy, preparing resources for job. 260
 - System busy, preparing resources for job. Deleting held job(s). 260
 - Unsupported disk 260
 - Unsupported USB device, please remove 260
 - Unsupported USB hub, please remove 260
 - USB/USB <x> 260
 - printer options troubleshooting
 - drawers 281
 - flash memory card 281
 - hard disk with adapter 281
 - Internal Solutions Port 282
 - memory card 282
 - option not working 280
 - paper trays 283
 - printer problems, solving basic 254
 - printing
 - directory list 99
 - font sample list 99
 - from flash drive 98
 - from Macintosh 93
 - from Windows 93
 - installing printer software 52, 135
 - menu settings page 51
 - network setup page 52
 - print quality test pages 100
 - two-sided (duplex) 93
 - printing confidential and other held jobs
 - from Macintosh computer 97
 - from Windows 97
 - publications, finding 16
- Q**
- Quality menu 221
 - Queued for sending 258
 - Quiet Mode 73
- R**
- recycled paper
 - using 88
 - recycling 298
 - Lexmark packaging 72
 - Lexmark products 72
 - toner cartridges 72
 - WEEE statement 298
 - reducing a copy 105
 - Remove originals from the scanner ADF 259
 - Remove packaging material, check <x> 259
 - Remove paper from standard output bin 259
 - Repeat print jobs 96
 - printing from Macintosh computer 97
 - printing from Windows 97
 - Replace all originals if restarting job. 259
 - reports
 - viewing 238
 - Reports menu 164
 - Reserve print jobs 96
 - printing from Macintosh computer 97
 - printing from Windows 97
 - resolution, fax
 - changing 139
 - Restore Held Jobs? 259
- S**
- safety information 14, 15
 - Scan Document Too Long 259
 - Scan Profile options 151, 152
 - scan profile options 151
 - scan quality, improving 153
 - scan to a computer
 - options 151, 152
 - scan troubleshooting
 - cannot scan from a computer 276
 - partial document or photo scans 276
 - scan was not successful 275
 - scanner unit does not close 272
 - scanning takes too long or freezes the computer 275
 - scanner
 - Automatic Document Feeder (ADF) 21
 - functions 20
 - registration 231
 - scanner glass 21
 - Scanner ADF Cover Open 259
 - scanner glass
 - cleaning 229
 - scanner glass (flatbed)
 - copying using 103
 - scanning to a computer 150
 - improving scan quality 153
 - scanning to a flash drive 153
 - scanning to an FTP address
 - creating shortcuts using the computer 146
 - creating shortcuts using the touch screen 147
 - improving FTP quality 149
 - using shortcut numbers 145
 - using the address book 146
 - using the keypad 145

- Securely clearing disk space 259
 - Security Audit Log menu 181
 - sending a fax using the
 - computer 134
 - Serial <x> 260
 - Serial <x> menu 176
 - serial port 66
 - serial printing
 - setting up 66
 - Set clock 260
 - Set Date/Time menu 182
 - setting
 - paper size 74
 - paper type 74
 - TCP/IP address 169
 - Universal Paper Size 74
 - setting up
 - fax 121
 - serial printing 66
 - setting up the printer
 - on a wired network (Macintosh) 61
 - on a wired network (Windows) 61
 - Settings menu 183
 - Setup menu 217
 - shipping the printer 236
 - shortcuts, creating
 - e-mail 115, 116
 - fax destination 137
 - FTP destination 146, 147
 - SMTP server not set up. Contact system administrator. 260
 - SMTP Setup menu 167
 - Some held jobs were not restored 260
 - standard exit bin
 - light 71
 - Standard Network menu 165
 - Standard USB menu 173
 - status of supplies, checking 233
 - steps
 - setting up printer 54
 - storing
 - paper 89
 - supplies 232
 - subject and message information
 - adding to e-mail 117
 - Substitute Size menu 158
 - supplies
 - conserving 68
 - status of 233
 - storing 232
 - using recycled paper 68
 - supplies, ordering 234
 - ADF pick assembly 235
 - ADF separator roll 235
 - photoconductor kit 234
 - system board
 - accessing 29
 - System busy, preparing resources for job. 260
 - System busy, preparing resources for job. Deleting held job(s). 260
- T**
- TCP/IP menu 169
 - telecommunication
 - notices 301, 302, 303, 304
 - tips
 - card stock 96
 - envelopes 94
 - labels, paper 95
 - letterhead 94
 - toner cartridges
 - recycling 72
 - touch screen
 - buttons 24
 - transparencies
 - loading 79
 - making 103
 - tips on using 94
 - tray linking 85
 - tray unlinking 85
 - trays
 - linking 84, 85
 - loading 75
 - unlinking 84, 85
 - troubleshooting
 - checking an unresponsive printer 254
 - checking an unresponsive scanner 275
 - contacting Customer Support 294
 - solving basic printer problems 254
 - troubleshooting, copy
 - copier does not respond 272
 - partial document or photo copies 274
 - poor copy quality 273
 - poor scanned image quality 275
 - scanner unit does not close 272
 - troubleshooting, display
 - display is blank 254
 - display shows only diamonds 254
 - troubleshooting, fax
 - blocking junk faxes 140
 - caller ID is not shown 277
 - can receive but not send faxes 279
 - can send but not receive faxes 279
 - cannot send or receive a fax 277
 - received fax has poor print quality 280
 - troubleshooting, paper feed
 - message remains after jam is cleared 283
 - troubleshooting, print
 - error reading USB drive 269
 - held jobs do not print 270
 - incorrect characters print 271
 - incorrect margins 286
 - jammed page does not reprint 283
 - job prints from wrong tray 271
 - job prints on wrong paper 271
 - job takes longer than expected 270
 - jobs do not print 269
 - Large jobs do not collate 271
 - multiple-language PDFs do not print 268
 - paper curl 287
 - paper frequently jams 282
 - tray linking does not work 271
 - unexpected page breaks occur 272
 - troubleshooting, print quality
 - blank pages 284
 - characters have jagged edges 285
 - clipped images 285
 - ghost images 285
 - gray background 286
 - poor transparency quality 293
 - print irregularities 287
 - print is too dark 290
 - print is too light 289
 - print quality test pages 284
 - skewed print 288
 - solid black streaks 288
 - solid white streaks 288
 - streaked vertical lines 291
 - toner fog or background shading 292
 - toner rubs off 292

- toner specks 293
- troubleshooting, printer options
 - drawers 281
 - flash memory card 281
 - hard disk with adapter 281
 - Internal Solutions Port 282
 - memory card 282
 - option not working 280
 - paper trays 283
- troubleshooting, scan
 - cannot scan from a computer 276
 - partial document or photo
 - scans 276
 - scan was not successful 275
 - scanner unit does not close 272
 - scanning takes too long or freezes the computer 275

U

- Universal Paper Size
 - setting 74
- Universal Setup menu 163
- unlinking trays 84
- Unsupported disk 260
- Unsupported USB device, please remove 260
- Unsupported USB hub, please remove 260
- USB port 50
- USB/USB <x> 260
- Utilities menu 222

V

- Verify print jobs 96
 - printing from Macintosh computer 97
 - printing from Windows 97
- viewing
 - reports 238

W

- Web site
 - finding 16
- Windows
 - wireless network installation 55
- wired network setup
 - using Windows 61
- wired networking
 - using Macintosh 61
- Wireless menu 171

- wireless network
 - configuration information 54
 - installation, using Macintosh 58
 - installation, using Windows 55

X

- XPS menu 228